

**CEREBELLUM: ESSENTIAL INVOLVEMENT IN A SIMPLE LEARNED RESPONSE**

A DISSERTATION SUBMITTED TO THE PROGRAM IN NEUROSCIENCES AND THE  
COMMITTEE ON GRADUATE STUDIES OF STANFORD UNIVERSITY IN PARTIAL  
FULFILLMENT OF THE REQUIREMENTS FOR THE DEGREE OF DOCTOR OF  
PHILOSOPHY

By

David Alan McCormick

May, 1983

(reformatted for distribution April, 2010)

I certify that I have read this thesis and that in my opinion it is fully adequate, in scope and quality, as a dissertation for the degree of Doctor of Philosophy.

  
(Principle Advisor)

I certify that I have read this thesis and that in my opinion it is fully adequate, in scope and quality, as a dissertation for the degree of Doctor of Philosophy.

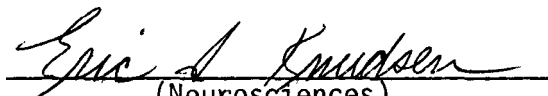
  
(Neurosciences)

I certify that I have read this thesis and that in my opinion it is fully adequate, in scope and quality, as a dissertation for the degree of Doctor of Philosophy.

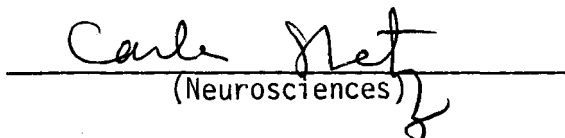
  
(Neurosciences)

Approved for the University Committee

on Graduate Studies:

  
Dean of Graduate Studies and Research

ACKNOWLEDGEMENTS

I would like to express my sincere gratitude to my principle advisor, Professor Richard F. Thompson, for his guidance, encouragement, and stimulating conversation throughout my graduate career. I would also like to express my appreciation to Drs. Eric Knudsen and Carla Shatz for their extreme helpfulness in the preparation of this dissertation and to Dr. Gregory A. Clark for taking the time to teach me many of the basic laboratory techniques which I have acquired. Laura Mamounas deserves thanks for her collaboration in collecting some of the cerebellar recording data, and for being a friend. I would also like to thank the unsung heroes of parts of this research: Carl Baier, Peggy Guyer, and Christina Rising. These three undergraduate students went well beyond the call of duty in our endeavor to uncover the neuronal circuitry involved in classical conditioning. A number of other people were responsible for keeping me healthy, and my morale high. Especially important were my brother and sister-in-law, Bruce and Barb, Deborah Haley, Ron Kettner, Dr. John Madden, and last, but most important, my fiancée, Lanch.

TABLE OF CONTENTS

List of Tables	6
List of Illustrations	7
Publications	11
Abstract	14
Introduction	16
Chapter 1:	
Training Paradigm	60
Chapter 2:	
General Methods	66
Chapter 3:	
The Effect of Cerebellar Lesions on the Classically Conditioned Eyeblink Response	77
Section A: Large ablations of the lateral cerebellum	77
Section B: Ablation of the cerebellum before learning	77
Section C: Stereotaxic lesions of the dentate- interpositus nuclei	86
Section D: Lesions of the superior cerebellar peduncle	90
Section E: Lesions of the cerebellar cortex	95
Section F: Possible mechanisms of cerebellar lesion effects	104
Chapter 4:	
Cerebellar and Brainstem Recordings and Stimulation	117
Section A: Brainstem recordings during performance of the learned eyeblink response	117
Section B: Cerebellum recordings during learning and performance of the learned eyeblink response	135
Chapter 5:	
Experiments on the critical inputs to the cerebellum	160
Section A: Effects of lesions of the middle cerebellar peduncle	166

Section B: Studies on the critical auditory input	167
Section C: Effects of lesions of the inferior olive	167

Chapter 6:

Overview of the Involvement of the Cerebellum in Classical Conditioning	186
Bibliography	200

## LIST OF TABLES

## CHAPTER 3 - CEREBELLAR LESION STUDIES

Effects of stereotaxic lesions of the dentate-interpositus nuclei on conditioned and unconditioned eyeblink responses. 72

## CHAPTER 5 - CRITICAL INPUTS INTO THE CEREBELLUM

Portions of the inferior olivary complex lesioned and the effect of the lesion on the conditioned eyeblink response. 180

## LIST OF ILLUSTRATIONS

## INTRODUCTION

1. Diagram of major divisions of the rabbit brain 18
2. Diagram of simple neural circuit which is capable of classical conditioning 20
3. Illustration of proposed neuronal circuitry involved in the plasticity of the vestibulo-ocular reflex; rabbit and monkey 32
4. Proposed mechanism for delay of movement and motor cortex unit activity after cooling of the dentate nucleus 46

## CHAPTER 1 - THE CONDITIONED RESPONSE

1. Illustration of classical conditioning training paradigm of the rabbit eyeblink response 61
2. Comparison of conditioning rates of the left nictitating membrane and the left and right eyelids 65

## CHAPTER 2 - GENERAL METHODS

- Histological example of reconstruction of electrode tract from micromanipulator recording technique 68

## CHAPTER 3 - CEREBELLAR LESION STUDIES

1. Example of movements of the nictitating membrane before and after lesion of the cerebellum 79
2. Histology of the smallest and largest ablations of the lateral cerebellum 80
3. Effects of ablation of the lateral cerebellum on the learned eyeblink response 81
4. Effect of ablation of the lateral cerebellum on the learning of the eyeblink response 82
5. Histology of the ablation of the lateral cerebellum before learning 83
6. Effect of bilateral lateral cerebellar ablation on the learned eyeblink response 84
7. Effect of lesion of the dentate-interpositus nuclei on the learned eyeblink response 87
8. Histology of the lesions of the dentate-interpositus nuclei 88

9. Effect of lesion of the superior cerebellar peduncle on the learned eyeblink response	91
10. Histology of the lesions of the superior cerebellar peduncle	92
11. Summary of lesions which abolish the learned eyeblink response	93
12. Effect of cerebellar cortical lesions on the learned eyeblink response	96
13. Effect of lesions of the ansiform-paramedian lobules on the learned eyeblink response	105
14. Histology of the cerebellar cortical lesions after learning	106
15. Composite histology comparing effective and ineffective cerebellar lesions	107
16. Photomicrograph of the inferior olive showing retrograde degeneration after cerebellar cortical lesion	108
17. Rate of learning of the eyeblink response in animals with ansiform-paramedian lobule lesions before learning	109
18. Individual learning rates of the animals with lesions of the ansiform-paramedian lobules	110
19. Average nictitating membrane responses of all animals with lesions of the cerebellar cortex before learning	111
20. Histology of the cerebellar cortical lesions before learning	112
21. Mechanisms of possible lesion effects	113
22. Coronal section from stereotaxic atlas illustrating position of dentate-interpositus nuclei	114
CHAPTER 4 - BRAINSTEM AND CEREBELLAR RECORDINGS	
1. Neural recordings from the facial, fifth sensory, and inferior colliculus during performance of the learned Response	117
2. Recording sites within the brainstem from which data was analyzed	118
3. Brainstem sites which produced neuronal activity related to the performance of the learned eyeblink response	119
4. Examples of neuronal responses recorded from the pontine nuclei red nucleus, superior colliculus, periaqueductal gray, reticular tegmental nucleus of the pons, and the fifth motor nucleus	123
5. Anterior sites of neuronal activity related to the occurrence of the conditioning stimuli	124
6. Posterior sites of neuronal activity related to the occurrence of the conditioning stimuli	132
7. Example of actual unit records recorded from the cerebellar dentate-interpositus nuclei and ansiform cortex	129
8. Sites within the anterior cerebellum which responded in relation to the performance of the learned eyeblink response	



	130
9. Sites within the posterior cerebellum which responded in relation to the performance of the learned eyeblink response	131
10. Average histograms of unit responses within the dentate-interpositus nuclei which respond in relation to the learned eyeblink response	132
11. Effect of misdirecting the airpuff away from the eye on dentate-interpositus neural responses	136
12. Example of increases in neuronal response within the dentate interpositus nuclei during learning of the eyeblink response	137
13. Individual example of changes in neuronal response pattern within the dentate-interpositus nuclei during learning	138
14. Graph of the increase in neural response within the dentate-interpositus during learning of the eyeblink response	143
15. Example of dentate-interpositus stimulation induced movements of the nictitating membrane	144
16. Summary of recording sites, stimulation sites, effective lesions, and ineffective cortical lesions.	148
CHAPTER 5 - CRITICAL INPUTS INTO THE CEREBELLUM	
1. Reconstructions of two lesions of the middle cerebellar peduncle	161
2. Reconstructions of two lesions of the middle cerebella peduncle	162
3. Nictitating membrane responses of animals with lesion of the middle cerebellar peduncle	163
4. Average nictitating membrane responses of animals with lesions of the inferior olivary complex	170
5. Amplitude of conditioned response in animal with lesion of rostro-medial inferior olive.	171
6. Amplitude of conditioned response on first training session after lesion for animal with lesion of the rostro-medial inferior olivary complex	172
7. Photomicrograph of lesion for animal with effective lesion of the rostro-medial inferior olivary complex	173
8. Composite histology of ineffective lesions of the inferior olivary complex	174
9. Composite histology of partially effective lesions of the inferior olivary complex	175
10. Composite histology of effective lesions of the inferior olivary complex	176
11. Representation of critical region of inferior olivary complex	177
12. Horseradish peroxidase injection into the critical region of the dentate-interpositus nuclei; labeling within the inferior olivary complex	183

## CHAPTER 6 - CEREBELLUM AND CLASSICAL CONDITIONING - OVERVIEW

1. Circuit diagram illustrating the known and proposed functional connections of the cerebellum in classical conditioning 193
2. Hypothetical circuit diagram of how the cerebellum may integrate sensory inputs to form a motor program 195



and resistance to extinction of a classically conditioned response: Involvement of the neocortex and the hippocampus. Brain Research 245 (1982) 239-250.

McCormick, D.A. Low cost oscilloscope histogram generator with memory. Physiology and Behavior 27 (1981) 1121-1125.

McCormick, D.A., Lavond, D.G., Clark, G.A., Kettner, R.E., Rising, C.E., and Thompson, R.F. The engram found? Role of the cerebellum in classical conditioning of nictitating membrane and eyelid responses. Bull. Psychon. Soc. 18 (1981) 103-105.

McCormick, D.A. and Thompson, R.F. Neuronal responses of the rabbit cerebellum during acquisition and performance of the classically conditioned nictitating membrane/eyelid response. Journal of Neuroscience (1984) 11: 2811-2822.

Lavond, D.G., Lincoln, J.V., McCormick, D.A., Thompson, R.F. Effects of bilateral lesion of the dentate/interpositus nuclei on conditioning of heart rate and nictitating membrane/eyeblink response in the rabbit. Brain Research 305:323-330.

McCormick, D.A., Steinmetz, J, and Thompson, R.F. Lesions of the inferior olive cause extinction of the classically conditioned eyeblink response. Brain Research (1985) 359: 120-130.

McCormick, D.A. and Thompson, R.F. Cerebellum: Essential involvement in the classically conditioned eyeblink response. Science (1983) 223: 296-299.

McCormick, D.A., and Thompson, R.F. Delayed extinction of a classically conditioned response in the rabbit induced by locus coeruleus lesions: Involvement of the neocortex and the hippocampus Neuroscience Abstract 7 (1981) 649.

McCormick, D.A., Lavond, D.G., Nelson, N.H., and Thompson, R.F. Neuronal responses of the rabbit brainstem and cerebellum during performance of the classically conditioned nictitating membrane/eyelid response. Neuroscience Abstract (1982) 8.

McCormick, D.A., and Thompson, R.F. How the cerebellum may be

involved in learning and retention of classically conditioned responses. Neuroscience Abstract (1983) Submitted.

Clark, G.A., McCormick, D.A., Lavond, D.G., and Thompson, R.F. Effects of lesions of cerebellar nuclei on conditioned behavioral and hippocampal responses. Brain Research (1984) 291: 125-136.

Lincoln, J.S., McCormick, D.A., Thompson, R.F. Ipsilateral cerebellar lesions prevent learning of the classically conditioned nictitating membrane/eyelid response. Brain Research 242 (1982) 190-193.

Lavond, D.G. McCormick, D.A., Clark, G.A. Holmes D.T., Thompson R.F. A non-recoverable learning deficit. Physiological Psychology (1984) 12: 103-100.

Lavond, D.G., McCormick, D.A., Clark, G., Holmes, D.T., Thompson R.F. Physiological Psychology 9 (1981) 335-339.

Thompson, R.F., McCormick, D.A., Lavond, D.G., Clark, G.A., Kettner, R.E., and Mauk, M.D. The engram found? Initial localization of the memory trace for a basic form of associative learning. In A.N. Epstein (Ed.) Progress in Psychobiology and Physiological Psychology. New York: Academic Press, Inc. (1982) 167-196.

Thompson, R.F., Barchas, J.D., Clark, G.A., Donegan, N., Kettner, R.E., Lavond, D.G., Madden IV, J., Mauk, M.D., and McCormick, D.A. Neuronal substrates of associative learning in the mammalian brain. In Alkon, D.L. and Farley, J. (Eds.), Primary neural substrate of learning and behavioral change. Princeton, NJ: Princeton Univ. Press (1983).

Thompson, R.F., Clark, G.A., Donegan, N.H., Lavond, D.G., Madden IV, J., Mamounas, L.A., Mauk, M.D., and McCormick, D.A. Neuronal substrates of basic associative learning. In L. Squire and N. Butters (Eds.), Neuropsychology of memory. Guilford Press, (1983) In press.

CEREBELLUM: ESSENTIAL INVOLVEMENT IN A SIMPLE LEARNED RESPONSE  
David Alan McCormick, Ph.D.  
Stanford University, 1983

Classical conditioning of the eyeblink response in the rabbit was used as a basic paradigm to study the neuronal structures involved in simple associative learning. Previous investigators have shown that no neural tissue above the level of the thalamus is essential for the learning of this response, implying that there must exist at or below the level of the thalamus some neural network which is capable of learning this response. In background work for analysis of the neuronal circuitry involved in the learning of this task, the muscular activity of the face during learning of the conditioned response was more clearly defined. The response is primarily ipsilateral with a weaker and more variable contralateral component and consists of a synchronous contraction of the facial musculature centering about closure of the eyelids and extension of the nictitating membrane (a cartilaginous third eyelid in rabbits and cats). A stereotaxic atlas of the rabbit cerebellum was prepared. Analysis of over 700 acute recordings from the ipsilateral brainstem and cerebellum indicated that the cerebellum and its related brainstem nuclei possess neural activity which is related to the performance of the learned eyeblink response. Furthermore, with chronic recordings it was found that the medial dentate and interpositus nuclei of the cerebellum develop

these responses in parallel with the learning of the response. Lesion of this region, its output pathway (superior cerebellar peduncle), or a major afferent, the rostro-medial inferior olivary complex, was found to permanently abolish the learned eyeblink response without affecting the reflexive eyeblinks or the ability of the animal to learn with the eyelids contralateral to the lesion. Lesions of the cerebellar cortex, lateral dentate nucleus, and fastigial nuclei were not found to permanently abolish the learned eyeblink response.

Stimulation of the critical region of the dentate-interpositus nuclei was found to elicit discrete eyeblinks, indicating that this region contains the necessary neuroanatomical connections to drive the learned eyeblink response. It is concluded that the dentate-interpositus nuclei are not only selectively involved in the production of learned eyeblinks, but since this neural region receives auditory and somatosensory inputs, it may contain essential changes in neuronal function which serve to encode this learned response. Alternatively, the changes in neuronal function may occur in afferent structures for which the cerebellum is a critical efferent.

"The movements of my left hand are done subconsciously, but I have to think out each movement of my right arm. I come to a dead stop in turning and have to think before I start again."

Patient of Gordon Holmes who had a lesion in the right cerebellar hemisphere<sup>117</sup>.

Perhaps the greatest asset which man has acquired through evolution has been his great capacity for learning; the ability to change his behavior as a result of experience. Learning and memory are such an important part of our lives, that in order to understand mankind, one must understand learning. Indeed, if the molecular-biochemical basis for any type of learning and memory could be determined, even for the simplest forms of learning, then significant progress toward a better understanding and way of life for all of us would be made. If we understood the basic mechanisms of learning and memory, the learning problems associated with old age, mental retardation, and other defects of the nervous system may one day be curable. Convinced of the important role which learning and memory plays in the lives of practically all animals, a number of investigators have fervently sought after the "memory trace", i.e. the changes in neuronal function which are synonymous with the memory of a particular task or event<sup>166,169,284</sup>. However, the localization of such a "memory trace" for complicated learning (e.g. maze learning in rats) seemed to be an impossible task. The failure of these



earlier authors to localize "learning centers" drove some to make quite radical statements such as "I sometimes feel, in reviewing the evidence on the localization of the memory trace, that the necessary conclusion is that learning just is not possible." (Karl Lashley, 1950<sup>169</sup>, or even to hypothesis that memories were not localized at all, but rather like holograms, in that every point participating in a memory represents the complete memory, although with much diminished resolution<sup>242</sup>. It appeared as though the question of learning and memory was too complex to answer with the available technology and understanding of the nervous system.

As a solution to this problem of complexity, a number of investigators undertook the study of simple forms of associative learning. Perhaps the simplest form of associative learning, and therefore presumably the easiest to solve, was discovered in the early 1900's by a Russian scientist, Ivan P. Pavlov. Pavlov, while studying the gastrointestinal tract of the dog (work for which he later won the Nobel prize), noticed that normal dogs came to salivate in response to conditions, situations and stimuli which were associated with food or being fed, although no food was present at the time. Pavlov went on to study this interesting phenomenon of the ability of a previously neutral stimulus (e.g. a tone or bell) to take on added meaning and to

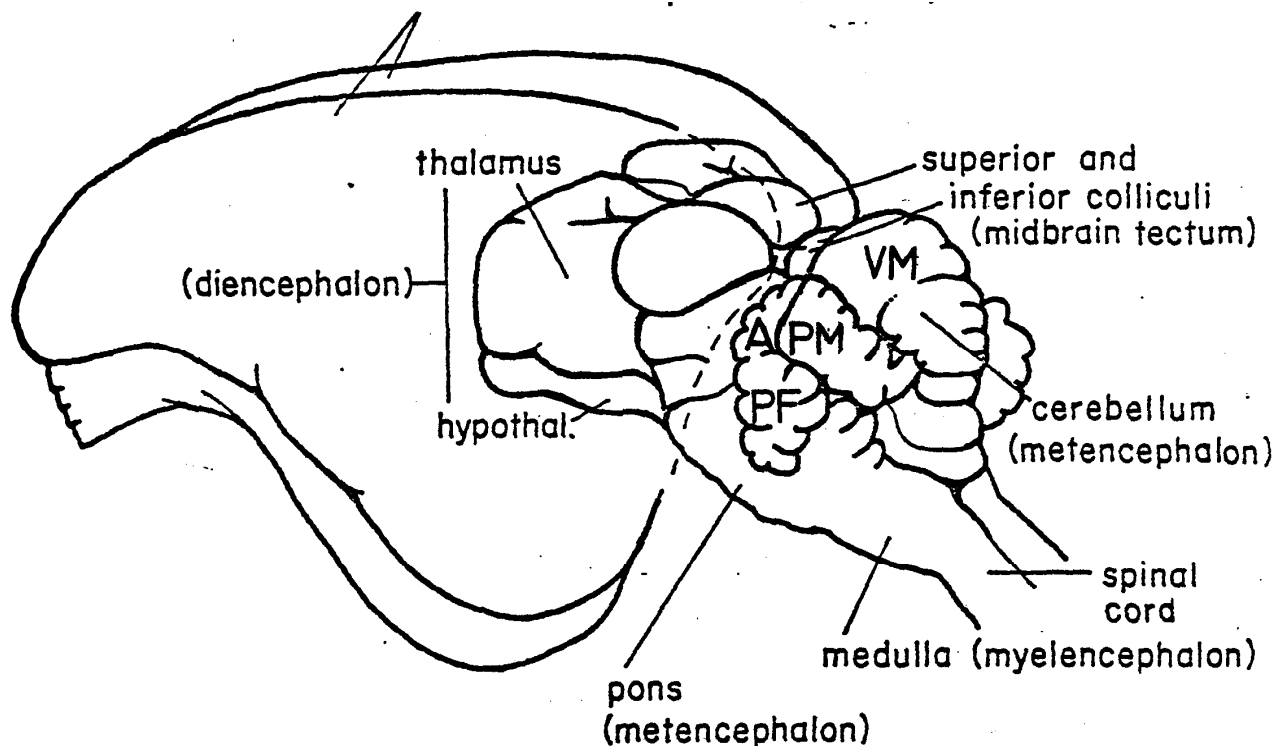

Figure 1 Drawing of the major divisions of the rabbit brain. Complete removal of the telencephalon does not prevent learning or retention of classically conditioned eyeblink response. Thus some neural circuit must exist at or below the level of the thalamus (diencephalon) which accounts for the learning of this response. The lobules of the cerebellum are also represented. The critical region of the cerebellar deep nuclei (see chapter 3) is located just beneath the ansiform (A) and paramedian (PM) lobules. The neural circuitry responsible for reflexive eyeblinks is located within the brainstem between the pons and medulla pointers. Abbreviations are as follows: A - ansiform lobule, hypothal. - hypothalamus, PF - paraflocculus, PM - paramedian lobule, VM - vermis.

cause a behavioral response (e.g. eyeblinks or salivation) after being associated in time with another stimulus which naturally elicited the response to be learned (e.g. an airpuff to the eye or the presence of food). This simple type of associative learning therefore came to be known as Pavlovian, or classical, conditioning. Pavlov himself felt that such learning took place within the cerebral cortex, since this brain structure is disproportionately large in humans. However, it is now known that animals with complete removal of the cerebral cortex or even all tissue above the thalamus can still learn relatively normally a number of classically conditioned responses<sup>36,92,171,178,211,219,221,222,223,224,235,236,250</sup>. Furthermore, animals which have been trained to perform a particular response, still retain the memory of that response after removal of the cerebral cortex<sup>221</sup>. These results imply that there must exist at or below the level of the thalamus (e.g. within the brainstem and cerebellum - see Figure 1) neuronal circuitry which is capable of undergoing, and actually does undergo, sufficient changes in neural function to encode the learning of the conditioned response. The quote at the beginning of this dissertation indicates that the cerebellum (see Figure 1) may be involved in the subconscious memory of well learned motor tasks, e.g. many classically conditioned responses.

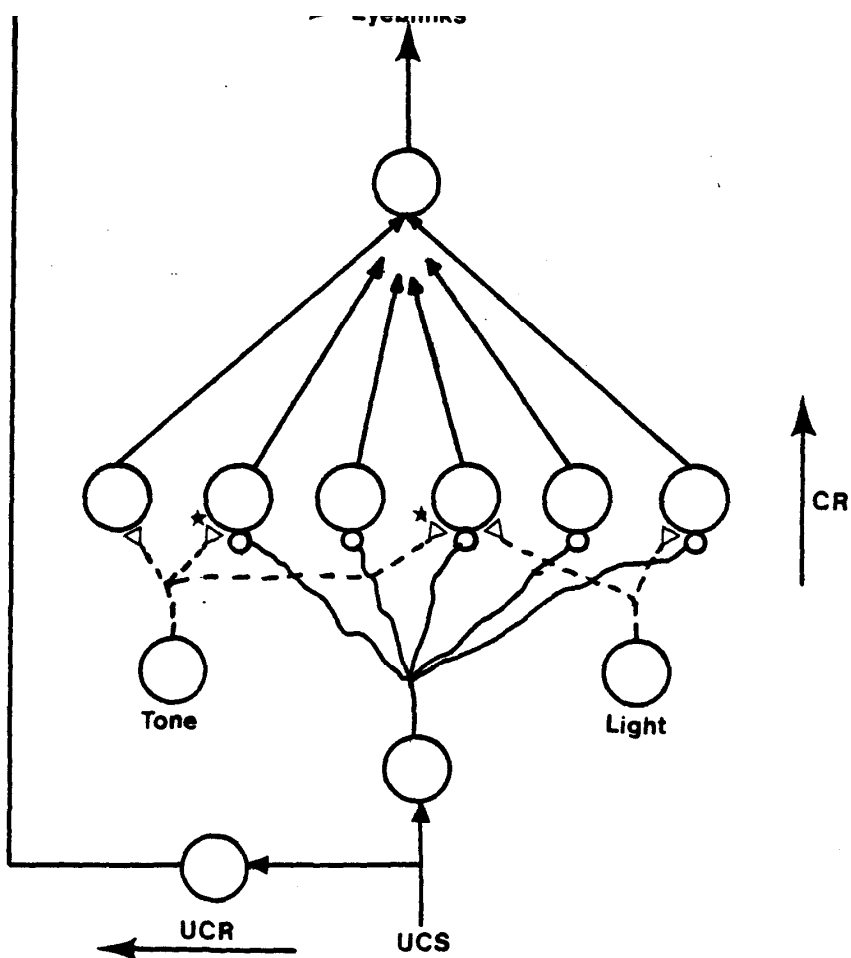

Figure 2 Diagram illustrating a hypothetical neuronal network which may account for learning of the eyeblink (and other classically conditioned) response. The unconditioned reflex (UCR) pathway is a short latency direct pathway from the corneal input (UCS) through two or three synapses, to the motor system controlling eyeblinks (i.e. the motor neurons). The UCS also activates neurons which project to a number of other brain regions. Some of these brain regions may also receive a weak, or sub-threshold, input from the neurons activated by the tone (conditioned stimulus). Where the conditioned stimulus and the UCS information converge, there is the opportunity for changes in the efficacy of the CS inputs to occur which are specific to the association of the CS and the UCS (stars). If the post-synaptic neurons also contain connections which allow them to cause the eyeblink response, then this change in synaptic efficacy may account for the learning of the eyeblink response. The inputs from other, non-learned, stimuli (light) remained unpotentiated.

The changes in neuronal function which form the "memory trace" are expected to be represented as some change in the synaptic efficacy between neural elements of some part(s) of the nervous system at or below the level of the thalamus. Thus, pairing a tone with an airpuff to the eye a sufficient number of times will result in the ability of the tone alone to cause an eyeblink response. Thus, the neural excitation-inhibition elicited within the nervous system by the presentation of the tone culminates in the excitation of the motoneurons controlling movements of the eyelids only after learning of the eyeblink response has occurred, i.e., the pathway of neural activity activated by the tone after learning has occurred is different from that which is activated before learning. The changes in neuronal function which are responsible for the ability of the tone to elicit the eyeblink response after learning are collectively referred to as the "memory trace" or the "engram" for the response under study. These words, within this dissertation, are not meant to indicate a special location within the central nervous system which is solely concerned with the storage of all associations that are learned, i.e., as a memory bank in a computer. Rather, as stated before, the memories are envisioned as a change in the properties of some parts of the neuronal circuitry normally involved in some way in the production of eyeblink responses. An instructive example of this

type of learning system is that of the recent work by Abrams, Carew, and Kandel<sup>42,108,139</sup>. These authors have found that classical conditioning of a siphon withdrawal reflex in a marine mollusk, Aplysia, results in an increase in the synaptic efficacy of the neurons which are both activated by the conditioned stimulus and also converge with input from the neurons excited by the unconditioned stimulus onto neurons which can produce the learned response (see Figure 2). This potentiation of synapses is specific in that the synaptic inputs caused by other stimuli which are very similar, but have not been associated with the unconditioned stimulus, do not become potentiated.

A somewhat similar behavioral paradigm is classical conditioning of the nictitating membrane-eyelid response in the rabbit<sup>69,98</sup>. The nictitating membrane is a third cartilaginous eyelid in rabbits, cats, and other animals, which extend from the front of the eye to the rear when the eyeball is retracted into the socket (see Chapter 1). By pairing a tone with an airpuff to the eye a short time later, a rabbit will learn to close his eyelids and extend his NM before the onset of the airpuff. Investigations of the changes in neuronal function which represent the learning of this response must complete two major tasks: 1. define the neural circuitry involved in the learning of this response, and 2. define the changes in this

neural circuitry which serve to encode the learning of this response. At the start of the research contained within this dissertation, the only neuronal structures known to be essentially involved in the learning and performance of this eyeblink response were: 1. the motoneurons controlling the response<sup>46,47,59</sup> (i.e. the animal must be capable of performing the response); 2. one or the other cochlear nucleus (i.e. the animal must be able to hear the tone) and 3. the fifth sensory nuclei (i.e. the airpuff must elicit eyeblinks). Evidence argued against localization of the "memory trace" to certain neuronal systems, e.g. motor neurons, reflex pathway, or the primary auditory relay nuclei<sup>151,190,286</sup>.

Several lines of evidence, including preliminary recording studies (see Chapter 4), suggested that the cerebellum might be involved. It has been reported in an earlier Soviet literature that cerebellectomy in the dog can prevent or severely impair the ability of an animal to perform classically conditioned leg flexion and salivary responses<sup>81,144,160,172,237</sup>. The research presented in this dissertation was performed to test the hypothesis that the cerebellum may be critically involved in the learning and/or production of classically conditioned eyeblink responses.

## The Cerebellum and Learned Movements - Overview

### Vestibulo-ocular reflex

The vestibulo-ocular reflex (VOR) constitutes a brainstem reflex which maintains visual image stability on the retina of the eye, even though movements of the head may be occurring. For example, if one fixates his gaze on an object and moves his head in any direction, he will find that his eyes rotate in an equal and opposite direction, thus maintaining visual image stability. During normal VOR performance, the gain of this system, defined as the magnitude of the smooth compensatory eye velocity divided by the magnitude of the head velocity, is very near 1.0, or perfect compensation. If such a system were without ability to change in response to changes in ocular mechanics (as during development) and/or loss of brain cells (i.e. cell death), then this gain would depart significantly from 1.0; therefore visual image stability during head movements would suffer significantly. It is easy to imagine that such departures from perfect gain should be evolutionarily maladaptive, and therefore selected against. That the VOR can change in response to experience has been shown in a number of species by using experimental situations in which a gain of 1.0 (normal) is no longer appropriate. For example, the wearing of reversing prism goggles<sup>93,94</sup>, 2X spectacle glasses<sup>87,205,206</sup>, or moving the visual



fields in various combinations with head movements<sup>72</sup> require significant alterations in the gain of the vestibulo-ocular reflex if retinal image stability is to remain the same.

In the VOR, the movements of the head are signaled by the semicircular canals of the inner ear in a frequency encoded signal which is proportional to head angular velocity. This complex input signal is further analyzed within the brainstem and cerebellum (flocculus) ultimately resulting in a very precise excitation-inhibition of particular motoneurons innervating the extraocular muscles<sup>54,240</sup>. The basic pathway of this reflex is a trineuronal arc: the vestibular organ excites cells of the vestibular nuclei in the brainstem which in turn excite or inhibit (depending on the direction of the head movement) the motoneurons innervating the extraocular muscles (see Figure 3). Thus the VOR is referred to as an open loop control system, since the output of the reflex does not directly influence the production of the presently ongoing reflex. However, over time, slippage of retinal images during VOR compensation may serve as an error signal to correct the gain of the VOR in order to ensure future image stability.

The floccular cortex of the cerebellum also receives direct input from the vestibular organ and from the vestibular nuclei and sends inhibitory connections back to the ipsilateral

vestibular nuclei. Thus the flocculus forms a side loop to the mainline vestibular pathway, which therefore may, through a decrease or increase in its synaptic efficacies, modify the ultimate gain of the VOR (see Figure 3). Lesions of the flocculus have been found in all species tested to block the adaptability of the vestibulo-ocular reflex<sup>107,122,130,227,244,249,267,268</sup>, therefore offering support to this hypothesis.

Two separate research teams have tested the hypothesis that the flocculus may be involved in the adaptive modifiability of the VOR on two separate experimental animals, the rabbit and the monkey. They have reported somewhat different and conflicting results, therefore I shall consider each independently before comparing the two.

#### Rabbit Hypothesis

Ito et al. have found that within the rabbit flocculus, only a particular zone is concerned with the horizontal vestibulo-ocular reflex<sup>125, 128</sup>. Recordings from the Purkinje cells of this zone during performance of the horizontal VOR have revealed that these neurons can fire either in phase or out of phase with the compensatory eye movements of the VOR in response to whole body oscillations. Therefore, since the Purkinje cells are inhibitory on their target neurons, the in-phase firing neurons serve to

depress the VOR while the out-phase cells serve to enhance the VOR. Thus, modulation of either of these two groups of Purkinje cells could modify the gain of the VOR (see Figure 3). In recording studies of these two classes of Purkinje cells during adaptive modification of the horizontal VOR, it was found that the out-phase modulation was increased during an increase in VOR gain and decreased during a decrease in VOR gain, suggesting that this change in out-phase modulation could have been causing the corresponding change in VOR gain<sup>72</sup>. However, in order for modification of synaptic efficacies within the flocculus to occur which change the gain of the VOR, some input signal, presumably caused by slippage of retinal image, must occur in order to determine which synapses are modified and when. Two putative neuronal pathways fulfilling these requirements have been described: one occurs via the inferior olive and the other via the nucleus reticularis tegmenti of Bectereu (RTP)<sup>125</sup>. Lesions of the inferior olive were found to mimic lesions of the flocculus, in that the adaptive modifiability of the VOR gain was abolished. However, these lesions may have had profound effects on the proper functioning of the Purkinje cells of the flocculus<sup>127,129</sup>, thereby confusing the issue of whether or not the deficit was due to a lack of an important signal from the inferior olive, or simply due to a lesion induced malfunction of the Purkinje cells in the flocculus. However, lesions rostral to

the dorsal cap of the inferior olive (the part of the 10 which projects to the flocculus) were found to abolish the adaptability of the VOR without disrupting Purkinje cell functioning<sup>127</sup>. These lesions presumably blocked visual information from the pretectal region from reaching the inferior olive.

In contrast, lesions of the RTP were not found to abolish the adaptability of the VOR gain, although the optokinetic response (eye movements in response to whole visual field movements) was reduced, implying that this visual pathway mediates optokinetic responses and not the adaptability of the VOR<sup>208</sup>. Therefore, it would appear that the visual signals relayed through the dorsal cap of the 10 are important in modifying the gain of the VOR. Thus, the climbing fiber input from the 10 to the Purkinje cells of the flocculus may be modifying the synaptic efficacy of the vestibular signals, which reach the Purkinje cells via the mossy fiber - granule cell parallel fiber pathway. This hypothesis brings us to a number of theories proposed by previous investigators as to the possibility that the cerebellar cortex may store motor programs<sup>1,24,186</sup>. The Purkinje cells of the cerebellar cortex receive two basic types of excitatory inputs: the parallel fibers of the granule cells and the climbing fibers of the inferior olive<sup>50,75</sup>. Each Purkinje cell receives synapses

from approximately 100,000 parallel fibers and synapses from only one or a very few climbing fibers, with the response elicited by the climbing fiber being extremely excitatory and the response elicited by a single parallel fiber only

In the monkey, however, all of the critical anatomical connections have not yet been found. However, a block diagram, which mimics what is known to occur within the monkey CNS, has been substituted instead. In this diagram the Purkinje cells also form an inhibitory side loop to the mainline vestibular signals of the brainstem. In recording studies, during adaptation to 2X magnifying lenses, the Purkinje cells were found to increase their sensitivity to vestibular signals. This increase in firing may have come about through elements C or A. However, an increase in A would serve to increase the inhibition of the VOR, and therefore make the compensatory eye movements smaller, and not larger, as needed in a 2X adapted state. Thus Miles and colleagues have proposed that the critical plasticity occurs within element C, with the dashed line representing a critical retinal error signal input from the Purkinje cells of the flocculus (Figures adapted from Ito 1982 and Lisberger 1982).

Thus, it has been proposed that the Purkinje cells may change their responses to a particular pattern of parallel fiber input

depending upon whether or not that input has occurred with a simultaneous (or nearly so) discharge from a climbing fiber. Therefore, since the vestibular signals reach the Purkinje cells as a parallel fiber input<sup>30,241</sup> and the retinal error signal reaches the Purkinje cells presumably by a climbing fiber input<sup>2,181,182</sup>  $n_0$  Ito et al. proposed that this model of learning within the cerebellar cortex may hold true for the adaptation of the VOR gain<sup>125</sup>. Thus, it is proposed that a retinal error slip signal reaches the out-phase Purkinje cells of the flocculus by the dorsal cap of the inferior olive. This error signal causes the parallel fibers which are presently active to decrease their synaptic efficacy, thus changing the inhibitory influence of the Purkinje cell side loop on the brainstem reflex pathway of the VOR, thereby changing the gain of the VOR (see Figure 3). In support of this hypothesis, Ito et al. have found that conjunctive stimulation of climbing fiber afferents and vestibular mossy fiber afferents causes a drastic depression of the responsiveness of floccular Purkinje cells to activation of vestibular fiber afferents<sup>131,132</sup>. Furthermore, climbing fiber responses were also found to decrease the sensitivity of Purkinje cells to iontophoretic application of L-glutamic acid, the presumed neurotransmitter of the parallel fiber pathway<sup>131,132</sup>.

Figure 3 Circuit diagrams for the proposed neuronal circuitry involved in the adaptive modifiability of the vestibulo-ocular reflex. In the rabbit, the floccular cortex forms an inhibitory side loop to the basic trineuronal arc of the vestibulo-ocular reflex pathway of the brainstem (vestibular organ - vestibular nuclei - eye muscle motoneurons). The Purkinje cells receive the vestibular signal via the granule cell -parallel fiber pathway and the retinal error signal via the retina -pretectal area - inferior olive - climbing fiber pathway. Thus it is hypothesized that an error signal reaching the Purkinje cells as a climbing fiber response decreases the synaptic efficacy of the co-activated parallel fiber synapses. By changing the amount of inhibition which travels through the floccular inhibitory side-loop, the gain of the VOR is changed.

In the monkey, however, all of the critical anatomical connections have not yet been found. However, a block diagram, which mimics what is known to occur within the monkey CNS, has been substituted instead. In this diagram the Purkinje cells also form an inhibitory side loop to the mainline vestibular signals of the brainstem. In recording studies, during adaptation to 2X magnifying lenses, the Purkinje cells were found to increase their sensitivity to vestibular signals. This increase in firing may have come about through elements C or A. However, an increase in A would serve to increase the inhibition of the VOR, and therefore make the compensatory eye movements smaller, and not larger, as needed in a 2X adapted state. Thus Miles and colleagues have proposed that the critical plasticity occurs within element C, with the dashed line representing a critical retinal error signal input from the Purkinje cells of the flocculus. (Figures adapted from Ito 1982 and Lisberger 1982).

RABBIT

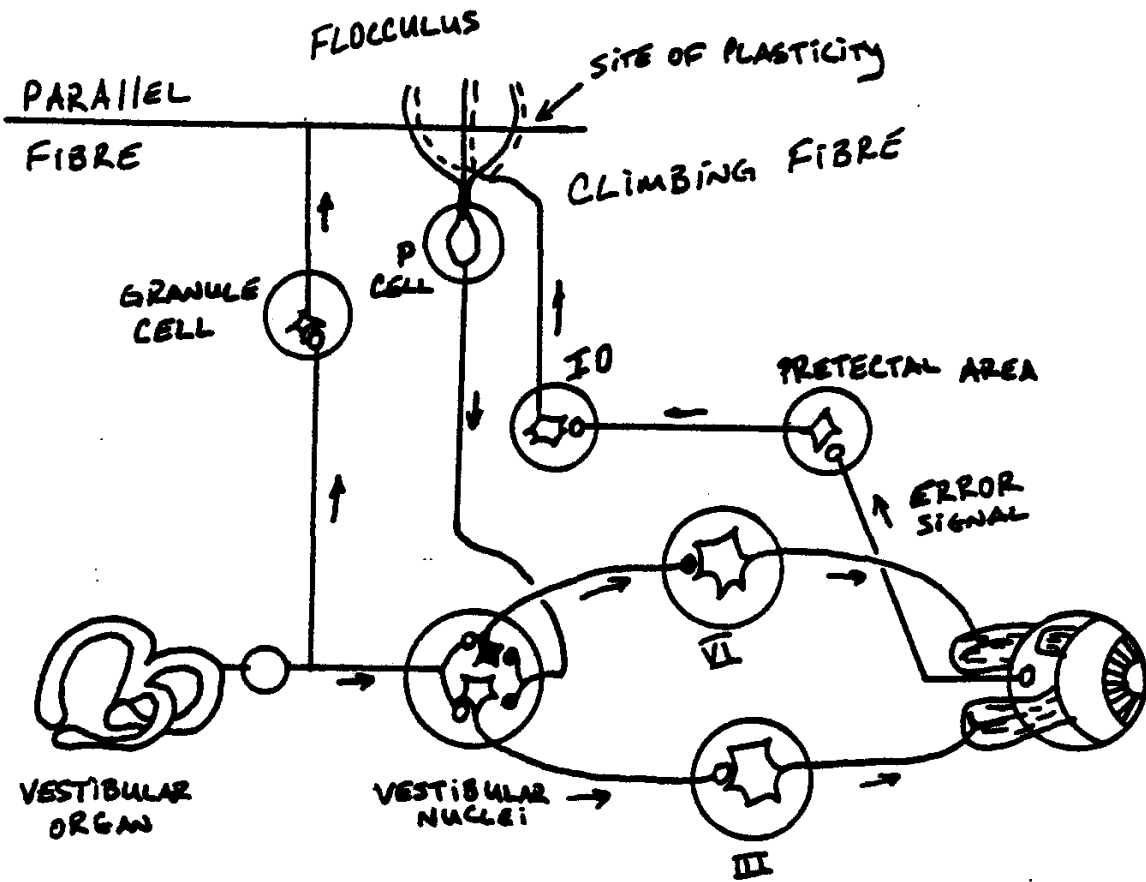

MONKEY

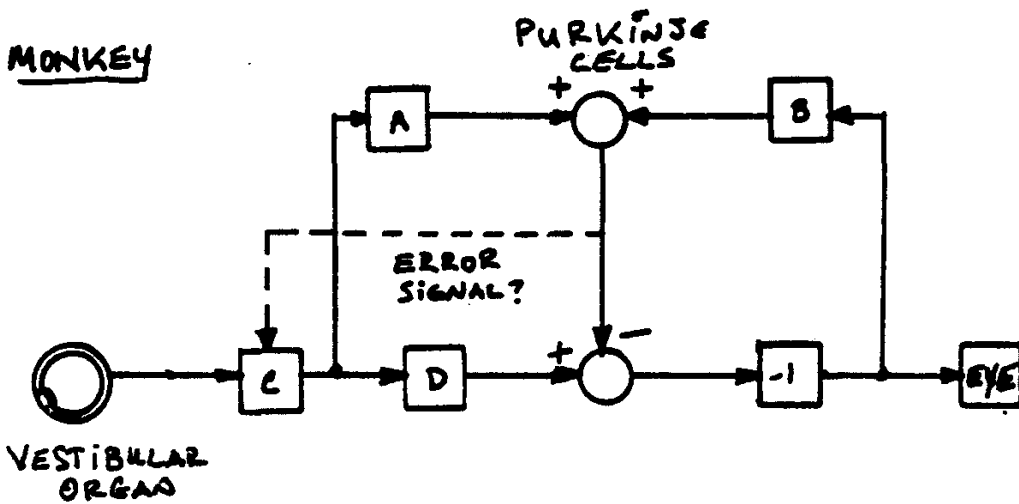



## Monkey Hypothesis

A somewhat different view of the role of the flocculus in the plasticity of the VOR has come about as a result of research on the monkey, done in large part by Miles, Lisberger and colleagues<sup>202,203,204,205,206</sup>.

In the monkey, as in the rabbit, lesions of the flocculus have been found to abolish the adaptability of the VOR, suggesting that this neural structure plays some important role in this form of neural plasticity. In studying the normal functioning of the flocculus with recording techniques, it was found that the Purkinje cells discharge in relation to two important signals: the normal vestibular input signaling angular head velocity with respect to the world; and in relation to eye velocity with respect to the head<sup>203</sup>. These two signals appear to sum algebraically to effectively encode gaze velocity with respect to the world. Thus in the normal animal, if the VOR is working properly (gain = 1.0), or in the adapted animal which has adjusted his gain to effectively eliminate retinal slip, the Purkinje cells will remain almost silent. Furthermore, since these Purkinje cells respond in relation to gaze velocity with respect to the world, they are active during smooth pursuit movements of the eyes, no matter what combination of head, eye, and body movements are employed<sup>203</sup>. Miles and Lisberger have

therefore suggested that the Purkinje cells of the flocculus contribute more to the smooth pursuit system than to the functioning of the VOR, either in the normal state or in the adapted state. However, if the vestibular signal (signaling head velocity with respect to the world) to the Purkinje cells is studied alone, it is found that this signal undergoes an increase in gain as the animal adapts to the magnifying lenses. In Figure 3, this increase in vestibular signal through the Purkinje cells could come about through elements C or A. Element A, for example, would be an increase in the synaptic efficacy of parallel fibers onto Purkinje cells. However, if the plasticity was within element A, then a corresponding increase in element D would also be necessary in order for proper compensatory movements to be performed. This is true, since in the 2X adapted monkey, the eye movements must be twice as large to maintain retinal image stability during head movements, and increasing the Purkinje cell inhibition would serve to decrease the gain, not increase it as needed. However, an increase in signal strength at element C would both increase the vestibular signal strength to the Purkinje cells as observed and increase the gain of the VOR. However, it must be remembered that in any case the total Purkinje cell output in the adapted state would be close to nil, since these cells relay gaze velocity with respect to the world and not the vestibular (head angular velocity) signal.

In either case (A+D or C), the critical plasticity would lie outside the flocculus, within the brainstem elements. Therefore, these authors feel that the flocculus is not necessary for the modifiability of the VOR because it contains the critical plasticity changing the gain of the VOR, but rather may form a pathway by which the retinal slip error signal reaches the brainstem site of the critical plasticity. They hypothesize that the Purkinje cells of the flocculus could contribute to this function, since they would respond during movements of the eyes with respect to the world as would be performed during voluntary correction of an incorrect VOR gain<sup>174,202,204</sup>.

#### VOR - Which theory?

The results of the monkey and rabbit work would therefore appear to be in conflict; in the rabbit the critical plasticity appears to lie within the mossy fiber - Purkinje cell synapses, whereas within the monkey system the critical plasticity does not appear to lie within the flocculus at all. Proponents of both hypotheses have pointed out viable concerns about the other group's hypothesis. Basically, the monkey flocculus appears to be much more complex than the rabbit flocculus, since the monkey performs a certain type of eye movements which the rabbit does not: smooth pursuit. This type of eye movement is exactly the type of eye movements which Miles and Lisberger have

found the monkey flocculus to be most involved in. Furthermore, the monkey flocculus is large (up to 10 different folia) compared to the rabbit flocculus (3 to 4 folia) and therefore these two groups of investigators may have recorded from different parts of the flocculus. Indeed, Ito and colleagues have found that only a small class of Purkinje cells (out-phase cells of Zone II) are important for the horizontal VOR, and do modulate their firing pattern in relation to adaptation of the horizontal VOR. Since Miles and Lisberger did not test for such micro-zonal structure, it is entirely possible that they may have missed the critical site of change within the flocculus (if it exists), as Lisberger himself has acknowledged - "It remains possible that the monkey recordings were made in a zone not involved in the horizontal VOR, and that recordings from another zone would support the rabbit hypothesis."<sup>174</sup>. Even though a respectable number (502) of Purkinje cells were recorded from, this may be small compared to the thousands or more of Purkinje cells which exist within the monkey flocculus. Furthermore, although these authors have drawn a hypothetical circuit diagram for the monkey VOR (see Figure 3, part B), the anatomy of the actual circuit is far from being complete, as is also acknowledged by Lisberger; "Although the anatomical circuit diagram is painfully incomplete for the monkey, the quantitative observations on Purkinje cell firing have led to general

acceptance of a block diagram representation ..." (Lisberger 1982)<sup>174</sup>. Lisberger also states "It is important that the reader does not attempt to relate our diagrammatic model to specific neuroanatomical connections." (Lisberger 1982)<sup>172</sup>. In my opinion, if the model is not representative of true neuroanatomical relations within the monkey CNS, it is of only limited applicability and credibility.

Taking all of this into consideration, the rabbit hypothesis, rather than the monkey hypothesis, would appear to be the more carefully documented and studied of the two theories. However, the monkey hypothesis has raised some interesting questions and some perspective problems with the rabbit hypothesis. Actually, until each investigating team finds neuronal plasticity which is sufficient and critical for the change in VOR gain, and which occurs in the natural situation, the question is largely academic. Furthermore, it is entirely possible that these two species of animal, which have in some respects very different nervous systems, may have solved the problem of adaptive changes in the gain of the VOR by two different methods. Hopefully, these questions will be answered within the next decade, and will help to further our rather limited understanding of the plastic modifiability of the central nervous system in mammals.

Prompt Arm-Wrist Movements in the Monkey

One major field concerned with programmed movements has been the study of prompt arm-wrist movements in the monkey. Basically, a monkey is well trained to perform a task consisting of moving a hand held manipulandum from one target zone to another after an auditory and/or visual GO! signal (e.g. a tone and/or a light). These movements are reasonably rapid (usually 100 - 300 milliseconds in onset latency), well learned (in one study the subjects were overtrained by 500,000 trials!), and stereotypical. However, variations upon this theme are frequent and therefore I will state the important differences in each procedure.

The two major techniques which have been used to study the role of the cerebellum in these prompt arm movements has been single unit recordings and stereotaxic lesions or reversible cooling of the dentate, and occasionally of the interpositus, nuclei. Perhaps one of the first investigations to study the relation of the activity of cerebellar unit activity and performance of voluntary movement was that of Thach (1968)<sup>277</sup> who recorded from Purkinje and deep nuclear cells of the cerebellum from monkeys while they rapidly alternated a bar from one stop to another<sup>277</sup>. Thach found that Purkinje cells of the anterior lobe had a steady discharge rate at rest of about 70 pulses per second and that this discharge often modulated (simple spike

activity, therefore probably representing a parallel fiber input) up and down from 0 to 400-500 pulses per second (pps) in relation to the performance of the movement. The Purkinje cell complex spike activity (presumably representing inferior olive input) occurred sporadically throughout the sequence, with no obvious relationship to performance of the learned movement. Deep nuclear cells (dentate-interpositus) were found to modulate their firing rate in a manner similar to that of the Purkinje cell simple spike activity<sup>277</sup>. Unfortunately, since the movement was an ongoing event, the timing relationship of this activity to particular components of the movement could not be determined (e.g. does this discharge precede the upcoming movement, or follow the just preceding movement?). Therefore, in order to study this timing relationship, Thach changed the paradigm to one in which the monkey was required to hold the manipulandum against one stop until (after a random interval) a light came on, then rapidly move the rod to the other stop and wait there until the light came on again, and then move the rod back to the original position. Thus the paradigm contained two maintained postures and two directions of prompt arm-wrist movements. Thach found that 82% of the dentate neurons recorded fired before the onset of the movement by up to 100 milliseconds (mean 50-60 msec). The interpositus neurons were found to fire somewhat later with a smaller percentage (42%) of these neurons firing

before the onset of the movement. Furthermore, these neurons also fired in relation to the maintained postures, and during spontaneous movements of the arm<sup>279</sup>. Similarly, Purkinje cells of the anterior lobe (which project mainly to the interpositus nuclei) also fired during performance of the movement. The onset of these responses, which were most often an increase in activity, were very similar to that of the interpositus neurons<sup>280</sup>. Therefore, since the Purkinje cells are inhibitory on the deep nuclear cells, Thach proposed that "...the Purkinje cell modifies through restraint the already initiated output of the nuclear cell" (Thach 1970)<sup>280</sup>.

In further studies, Thach found that the onset latencies of responsive neurons in the arm area of the motor cortex also often preceded the onset of the movement (by up to 130 milliseconds, although the EMG activity may also precede the movement by up to 120 milliseconds). Furthermore, recordings from dentate neurons in the same monkeys found that the distribution of onset latencies of these neurons preceded the distribution of the onset latencies of the motor cortex and EMG activities, although the distributions overlapped almost completely<sup>281</sup>. In an effort to differentiate exactly what part of the arm-wrist movement the neurons were responding to, Thach performed an experiment in which the monkeys were required to



move a manipulandum, upon signal from a GO! light, to a series of three different positions. By studying the position of the arm-wrist during the movement and the forces required to perform the task, Thach developed three separate classifications of neural responses: 1) those which responded in relation to the pattern of musculature activity required to hold the wrist in position (MPAT), 2) those which respond in relation to angulation (i.e. position) of the wrist joint (JPOS) and 3) those which respond to set for direction of the next intended movement (DSET). It was subsequently found that interpositus neurons, as well as EMG activity, responded in relation to MPAT, while the dentate nucleus and motor cortex possessed neurons which fell into all three classifications<sup>282</sup>. The temporal distributions of these responses from the different nuclei were found, as before, to overlap considerably, although small differences did exist. Thus the distributions were ordered in time as dentate, motor cortex, interpositus, muscle. During a transient force which briefly perturbed the wrist from its held position, the timing sequence was reversed<sup>282</sup>. Thus, this data is consistent with the notion that the dentate nucleus may be concerned with the planning and initiation of a learned movement, while the interpositus may be largely concerned with the follow up control of the movement. The lesion and reversible cooling data is somewhat consistent with this hypothesis (see

below). Burton and Onoda found that neurons within the interpositus nucleus of the cat fire in strong relation to the velocity of forelimb movement in an extension-flexion task, with the neurons in the interpositus responding near or just after the movement itself. These authors therefore state that "These conclusions are consistent with the suggestion that the intermediate zone of the cerebellar cortex and the interpositus nucleus integrates inputs from the cerebrocerebellar and spino-cerebellar systems to provide an output which continually updates the motor commands in the control of an evolving movement" (Burton and Onoda 1977)<sup>40</sup>. A similar function has also been proposed for the function of the red nucleus<sup>229</sup>. Thus Otero recorded from the red nucleus and motor cortex of the monkey while the subject was required to perform a prompt arm-wrist movement from holding down one key to holding down another key upon signal from a light. Otero found that the red nucleus neurons fired significantly later than the precentral gyrus (peak of red nucleus activity was 120 msec after peak of motor cortex activity), which is even greater than the difference between precentral gyrus activity and postcentral gyrus (somatomotor cortex) activity in the same task. Thus 91% of red nucleus neurons fired after the first EMG activity (as opposed to 37% of the precentral gyrus neurons). Therefore, taking into account the known connections of the red nucleus with the

precentral and postcentral gyri as well as the cerebellum, Otero proposed that "... it seems possible that the activity in red nucleus was dependent upon the combined actions of these two inputs, with sensory feedback from movement (relayed via postcentral gyrus and/or cerebellum) being one input, and a central program from cerebellum and/or precentral gyrus being the other input" (Otero 1976)<sup>229</sup>.

### Lesions and Reversible Cooling

Other researchers have chosen to study the contribution of the cerebellum to learned arm-wrist movements in the monkey by performing lesions or reversible cooling of the dentate and/or interpositus nuclei. First, it should be mentioned that in no case have lesions of the cerebellar deep nuclei<sup>9,37,38,164,201,207,281,289</sup>, or even complete cerebellar ablation<sup>165,247,248</sup> been found to abolish the monkeys ability to perform the learned prompt arm movement sequence. The major deficit after cooling or lesion of the dentate nucleus is found to be a delayed (100-200 msec) onset of the learned movement.

Among the first investigators to study the effects of exclusion of the dentate-interpositus nuclei on signaled arm-wrist movements in the monkey were Meyer-Lohmann, Hore, and Brooks<sup>201</sup>. in this study the monkeys were trained to hold the

manipulandum in one target zone until a light signal, upon which the monkey was required to promptly move the manipulandum to the opposite target zone, as described in a recording study above<sup>279</sup>. Cooling of the region of the dentate-interpositus nuclei with cooling probes just medial and just lateral to the dentate nucleus was found to delay the onset of the signaled movement by up to 100 milliseconds without affecting the amplitude-time course of the subsequent movement. Furthermore, these authors found that neurons of the motor cortex which fired in relation to the performance of the movement were also delayed in time by an equal amount. Cooling of the dentate alone appeared to be sufficient to have these effects, although the interpositus could not be completely ruled out. These authors proposed that the cerebellum participates in the initiation of the movement through the motor cortex and brainstem, as in the scheme of Figure 4. In discussing the possible pathways by which the dentate nucleus may influence the prompt movements, these authors state "No matter how these problems will be resolved in the future, it would appear that the fastest pathway for generation of movement is one involving the cerebellum, because movement onset is delayed when this pathway is blocked" (Meyer-Lohmann et al. 1977)<sup>201</sup>. Sasaki et al. have found that unilateral hemispherectomy of the cerebellum delayed prompt arm movements by 90-250 msec as well abolishing a cortical

evoked potential (presumed to be thalamocortical) within the motor cortex which was associated (pre-lesion) with the performance of the learned movement<sup>247,248</sup>. If the dentate-interpositus nuclei were included in the lesion the delay in onset was found to last for many months, although if the interpositus nucleus was spared, there was an earlier recovery of prompt movement and reappearance (simultaneously) of the pre-movement evoked potentials in the motor cortex<sup>248</sup>. Similarly, Trouche and Beaubaton found that cooling or electrolytic lesions of the dentate nucleus produced a prolongation of the reaction times in all animals without causing deficits in direction or amplitude<sup>289</sup>. Furthermore, cooling of the dentate nucleus never caused suppression of the movements; the animals continued to perform the required sequence without any necessity for retraining. This result shows that the monkeys do not need to relearn the movement after exclusion of the dentate nucleus, but rather fail to generate the movement with the same promptness as before the exclusion. Similar results were reported by Holmes (1917), who observed that human patients with cerebellar lesions generated prompt movements which were delayed by 100-200 milliseconds from normal<sup>116</sup>.

Results such as these have served as the impetus for some authors to hypothesize "... we would look to the limbic system

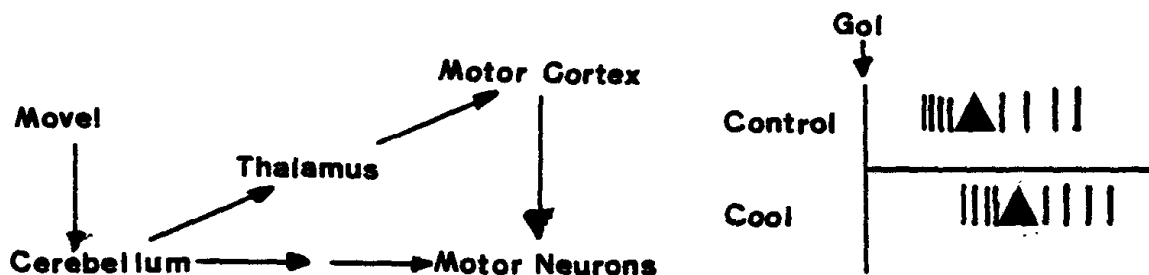

Figure 4 Diagram of possible mechanism for dentate cooling induced delay of precentral gyrus neuronal discharge and movement initiation of prompt arm-wrist movement in the monkey. The command to move is envisioned as causing the cerebellum (dentate) to initiate the movement through the thalamo-motor cortical connection as well as some lower (brainstem?) route. Cooling of the dentate thus leads to both a delay of the initiation of the movement and discharge of neurons in the motor cortex. On the right is an example of unit discharge (lines) and movement onset (triangles) before and after cooling of the ipsi-lateral dentate nucleus. Adapted from Meyer-Lohmann et al. J. Neurophysiol. 40 (1977) 1038-1050.

for the drive to move, and thence to the frontal and parietal cortex for the formation of the needed associations, to be channeled by the way of the cerebellum and basal ganglia through the thalamic funnel of the ventrolateral nucleus to the motor cortex" (Brooks 1969)<sup>38</sup>. However, the importance of this pathway has come under serious question since cooling or lesions of the ventrolateral thalamus as well as lesions of the pyramidal tract have no effect on the simple reaction time of prompt movements<sup>10,41,109,110,207</sup>. Furthermore, lesions of the ventrolateral thalamus or the red nucleus have different effects on execution of ballistically initiated movements of the forearm than do cerebellar lesions. Also, it has been shown that limb movements generated in response to stimulation of the dentate-interpositus nuclei are not abolished after transection of the brain stem between the level of the decussation of the superior cerebellar peduncle and the red nucleus, whereas they are abolished if the brainstem is transected as the superior cerebellar peduncle leaves the cerebellum to where it decussates<sup>253</sup>. Lashley reported in 1924 that bilateral lesions of the motor cortex in the monkey did not prevent the retention and performance of learned habits of manipulation and visual discrimination<sup>168</sup>. Similarly, monkeys trained to solve a number of complex problem boxes are not found to be deficient after complete bilateral section of the middle cerebellar peduncle, thus disconnecting the major pathway by

which the cerebral cortex communicates with the cerebellum<sup>292</sup>. Although these last two results are not of rapid ballistic movements, they indicate that cerebro-cerebellar interrelations appear not to be critical for the retention and performance of complex tasks (see section on more complicated tasks below). These results imply that the cerebellum can effect and generate movements not only through its cortical relations, but also through its brainstem connections (see Figure 4).

Conrad and Brooks also studied the effects of dentate cooling on rapid arm oscillations in the monkey. In this experiment, the monkey was required to move a rod back and forth between two mechanical barriers. When the dentate nucleus was cooled, it was found that the protagonist muscle discharged longer than usual by 100 to 200 msec. Thus the manipulandum was pressed against the mechanical stop for that length of time<sup>55</sup>.

Somewhat similar results have been reported by Soechting et al. These investigators trained monkeys to make an arm-wrist movement in order to obtain a food reward. Lesions of the deep cerebellar nuclei were found to cause disruption of the proper timing of the agonist-antagonist muscle contractions. Furthermore, the agonist muscle activity was found to persist for an abnormally long time<sup>259</sup>.



Horvath et al. trained monkeys to press a bar in a particular spatial position, then move to another bar, press it and then move back to the original bar, all without visual guidance of the task. When the position of the bars was changed, normal monkeys learn the task in the next few trials with longer and more variable reaching and pressing times. These reactions were quicker and more accurate as learning of the new positions progressed, with the new movements soon becoming as proficient as the old, well learned movements. Dentate cooling, however, reversed these proficient arm movements to the pre-learning level of proficiency (i.e. longer and more variable reaching and pressing times)<sup>118</sup>.

In summary, learned arm-wrist movements in the monkey appear to involve a number of neural elements including the cerebral cortex, cerebellum, thalamus, basal ganglia, red nucleus, brainstem elements and spinal cord, just to name a few. It would therefore appear the generation of the learned movement would come about as a "concert" of activity of these different neural elements, although some neural regions (e.g. cerebellum) may be more critically involved in one particular aspect of movement (e.g. prompt initiation) than some of the others.

Hemilabyrinthectomy - Role of the Flocculus in VOR Compensation

Unilateral labyrinthectomy in the cat is found to produce a marked spontaneous nystagmus and asymmetry of the VOR which, in normal animals, recovers progressively within about one week<sup>57,58</sup>. This spontaneous nystagmus is characterized by rapid involuntary eye movements with the fast phase of eye movements directed towards the intact side. Furthermore the VOR is decreased to excitation of the lesioned labyrinth and increased to excitation of the non-lesioned labyrinth. Recovery from this VOR asymmetry begins with an inhibition of the non-lesioned labyrinth VOR responses and a disinhibition of responses elicited by rotation towards the lesioned side. Therefore, although symmetry is being achieved in the following week after the lesion, a depression of both directions of the VOR is evident. This depression decreases in later weeks as the symmetry further increases. Thus by about 6 weeks a relatively normal VOR is re-established with no spontaneous nystagmus<sup>57,58</sup>.

Since the flocculus receives primary and secondary inputs from vestibular neurons<sup>44,256</sup>, from eye movement related neurons in the pontine reticular formation<sup>218</sup>, from extraocular muscle proprioceptors<sup>183</sup>, and from the visual system<sup>181,182</sup>, it is reasonable to propose that the floccular cortex of the cerebellum may contain, or be involved in the establishment of, the changes in neuronal function which lead to recovery of

normal VOR after Hemilabyrinthectomy. The contralateral flocculus, which projects to the intact vestibular system after unilateral labyrinthectomy, may therefore be critically involved in the recovery of the symmetry of the VOR after such.

Courjon et al. tested this hypothesis by two experiments: hemi-flocculectomy followed by hemilabyrinthectomy and hemilabyrinthectomy followed by hemiflocculectomy. These authors found that hemiflocculectomy after hemilabyrinthectomy resulted in both a much prolonged spontaneous nystagmus and a large asymmetry (recovered to 30%) in the VOR. These deficits persisted until the end of the testing period (99 days). Furthermore, in comparison to the recovery of normal animals (70% VOR recovery in 40 days), these results reveal that animals with removal of the contralateral flocculus are severely deficient in recovering from the effects of hemilabyrinthectomy. However, if the hemiflocculectomy is performed after recovery from the hemilabyrinthectomy, then the animals respond with only a transient bout of spontaneous nystagmus (5 days) and asymmetry of the VOR (10 days). Thus the flocculus would appear to be important for the formation of recovery (e.g. recalibration) but not for the maintenance of recovery.

#### Hemilabyrinthectomy - Postural Adjustments

A somewhat similar, but of a different behavioral measure, series of experiments were performed by Llinas and colleagues<sup>176,177</sup>. Following hemilabyrinthectomy not only is there spontaneous nystagmus and asymmetry of the VOR, but also a whole series of postural compensations take place in a somewhat predictable behavioral pattern and time course. It is this postural adjustment which Llinas and his colleagues chose to study as a model of "motor learning".

Immediately after hemilabyrinthectomy, there is a vigorous rolling of the whole body towards the ipsilateral side followed some 30 minutes later by turning in a tight circle towards the lesioned side. This turning behavior continues for some 10-24 hours after which relatively normal posture is achieved. Head position is also severely disrupted, although compensation begins at about 10 - 20 minutes post-lesion and reaches approximately 20 degrees off perpendicular within one hour. Complete head position is then fully recovered asymptotically. If an animal which has fully recovered (up to one full year post lesion) from the hemilabyrinthectomy, is subjected to lesion of the inferior olive by the selective neurotoxin 3-acetylpyridine (3-AP), the animal immediately returns to the uncompensated state and does not recover<sup>176,177</sup>. Furthermore, if inferior olive lesions are made one year before hemilabyrinthectomy, the

animals do show some recovery, although this recovery is much slower than normal and is never complete. Lesions of the fastigial nucleus of the cerebellum have been found to have a similar effect<sup>43</sup>. Therefore it would appear that the inferior olive and cerebellar fastigial nuclei are critically involved in the recovery process (although data from lesion experiments alone can never prove this).

To test the hypothesis that the granule cell - parallel fiber system within the cerebellar vermal cortex (which projects to the fastigial nucleus) is necessary for the recovery of posture, Llinas et al. X-irradiated this portion of the cerebellum in the neonatal rat and produced severe decrement in the granule cell populations. It was found that these animals were able to compensate, although this compensation occurred more slowly. Llinas et al. have also reported that short term complete removal of the cerebellar cortex does not block the ability of the rats to compensate, although no histology is presented, which may be important considering the results of the previous section on the role of the flocculus<sup>176</sup>.

Therefore, it would appear that the olivo-deep cerebellar nuclear connection is in some way necessary for correct postural compensation after hemilabyrinthectomy. It would also appear

that, although the cerebellar cortex exerts a modulatory influence on this compensation, this cortical contribution is not essential for proper compensation to occur.

Llinas and Walton in their discussion argue that the cerebellar cortex is more of an organ of motor regulation than the locus of "motor programs": "The answer seems to be, once again, that the cerebellum is primarily an organ of regulation rather than one directly involved, via plastic modifiability, in the acquisition of new motor skills"<sup>177</sup>. Although my own data, as far as the cerebellar cortex is concerned (see Chapter 3), would support such a stance, I would not go so far as to say that the cerebellar cortex is not capable of undergoing important changes in connection and function during motor learning. Indeed, lesion results can never reveal whether or not a structure normally forms neuronal plasticity, but rather may reveal whether or not that structure is necessary for normal learning to occur.

#### Active Avoidance

Most of the work on active avoidance paradigms has been performed on varying species of fish. For example, Kaplan and Aronson trained fish using a light conditioned stimulus (CS) to cross over from one side of a tank through a small hole in a barrier to the other side of the tank in order to avoid

receiving a shock delivered through the water. The interstimulus interval was 2.5 seconds. After cerebellar ablation, the fish were severely deficit in learning the behavioral avoidance response. Indeed, some animals failed to learn the response at all, even though the cerebellar ablated fish could not be distinguished (24 hours post-lesion) from non-ablated fish on the basis of posture, locomotion, or feeding behavior. Lengthening of the interstimulus interval to 10 seconds helped some animals to avoid, although a number of animals still did not successfully avoid the shock. In contrast, removal of the forebrain had a much more minor effect, with most of the animals recovering the response<sup>140</sup>. The same effects of cerebellar ablation of conditioned avoidance responses in fish have been reported by a number of other authors<sup>14,143,144,185</sup>.

To investigate further the generality of cerebellar lesion induced lost of learned avoidance, Karamian et al. also removed the cerebellum in two species of amphibia (Rana Ridibunda and Bufo Bufo) and in one species of reptile (Varanus Griseus) and tested these animals in a conditioned avoidance paradigm. No deficits in the learning or retention were found either in the amphibians or reptiles<sup>142,144</sup>.

Similarly, it has been reported that bilateral lesions of the cerebellar deep nuclei in the rat do not abolish the

ability of the animal to learn a two way active avoidance task<sup>83</sup>, although lesions of the fastigial nucleus and medial interpositus caused a slower (2X slower) acquisition of the task. In contrast, lesions of the dentate and lateral interpositus actually improved acquisition of the task.

Therefore the cerebellum appears to be essentially involved in the learning and retention of avoidance responses only within some species of animals. Thus Kararnian et al. suggested that the fish cerebellum "... participates in the formation of temporary connections"<sup>144</sup> when vision and audition are involved.

#### Complex Tasks

Lashley and McCarthy were perhaps the first investigators to test the possibility that the cerebellum is involved in the memory of complex motor tasks<sup>167</sup>. In 1926, in their endeavors to find the "engram" for maze learning in the rat, Lashley and McCarthy lesioned the cerebellum in seven animals. These lesions were mainly of the midline cortex, although in some animals the lateral cortical regions were also included. Four of the animals with lesions restricted to the cerebellar cortex failed to show any retention deficits upon testing in the maze in which they were previously trained. Similar results were found with two additional animals whose lesions encompassed the midline cortex,



lateral cortex, and damage to the dentate nuclei. One additional animal with complete removal of the cerebellum (a cyst was found where the cerebellum used to be) was capable of relearning the maze habit after a long period of recovery. The animal was, however, very sickly, and therefore pre-lesion - post-lesion comparisons in learning rates could not be made. However, this animal did relearn the maze to perfect performance without a cerebellum. Therefore the cerebellum could not be said to be absolutely essential for this type of learning, although it may be in some way modulatory of such. The lesions of the other six animals do not completely exclude the possibility of a modulatory involvement of the cerebellar cortex in maze learning, since some cortical regions were *never* lesioned in any of the six animals.

Robert Thompson, in his efforts to locate the "visual memory system" in rats, completely removed the cerebellum in one animal and tested this animal in three separate two-choice visual discrimination tasks in order to avoid foot shock. This animal showed perfect retention of all three discrimination tasks, despite typical locomotor ataxia<sup>283</sup>.

Peters and Filter trained food deprived rats to cross a very narrow bridge (0.8 cm wide by 60 cm long) in order to obtain a food reward on the other side. Normal rats found this task very

difficult, requiring good motor coordination and control of foot placement. Even so, animals with lesions of the cerebellar cortex, before or after learning, midline or hemisphere, were capable of learning and/or performing the task. However, rats with removal of the caudal vermis did perform the task more poorly, taking more time to cross the bridge and making more slips and falls<sup>234</sup>.

Turner and German, as mentioned previously, found that monkeys with unilateral or bilateral section of the middle cerebellar peduncle, thus blocking most cortico-cerebellar communication, exhibited perfect retention and ability to solve a number of previously trained problem boxes requiring manipulative skill of the hand and arms<sup>292</sup>.

### Summary

In summary, the cerebellum appears to be modulatory of, but not essential for, the learning and/or performance of a number of motor tasks. Thus critical involvement of the cerebellum in the performance of learned motor tasks appears to be a complex equation involving a number of variables including species, task difficulty, response requirements and training paradigm, to name a few. One training paradigm in which the cerebellum may be essentially involved is classical conditioning of motor

responses. Previous Russian investigators have found evidence for the involvement of the cerebellum in classical conditioning, although some of these authors contend that this is only a modulatory influence<sup>81,144,160,172,237</sup>. However, due to inadequate histological control, many of these studies are uninterpretable. The remainder of this dissertation represents an attempt to test the possibility that the cerebellum is involved in classical conditioning, and if it is involved, to define more clearly its role in this basic form of associative learning.

## CHAPTER 1: TRAINING PARADIGM

The learning paradigm used in the experiments contained within this dissertation was classical conditioning of the nictitating membrane response in the albino rabbit. The nictitating membrane (NM) is a third cartilaginous eyelid in rabbits and cats which extends from the front of the eye (nasal canthus) to the side or rear when the animal retracts its eyeball (see Figure 1).

After recovery from surgery, each animal was placed in a Plexiglas restrainer within a sound isolation chamber and allowed to adapt for a period of two hours. Headgear containing the airpuff outlet nozzle, first stage FET amplifiers, and a minitorque potentiometer was attached to the animal's headstage during adaptation and behavioral training. The left eyelids were held open by eyeclips and the movement of the NM was monitored by attaching a thread from the wire wiper arm of the minitorque potentiometer to the suture in the animal's NM.

Throughout training the conditioned stimulus (CS) was a 350 msec, 1 kilohertz tone at 85 dB SPL (measured at the animals' head) for the recording studies, or a 350 msec, 36 dB spectral level white noise stimulus for the lesion studies. The unconditioned stimulus was a 100 msec airpuff directed at the

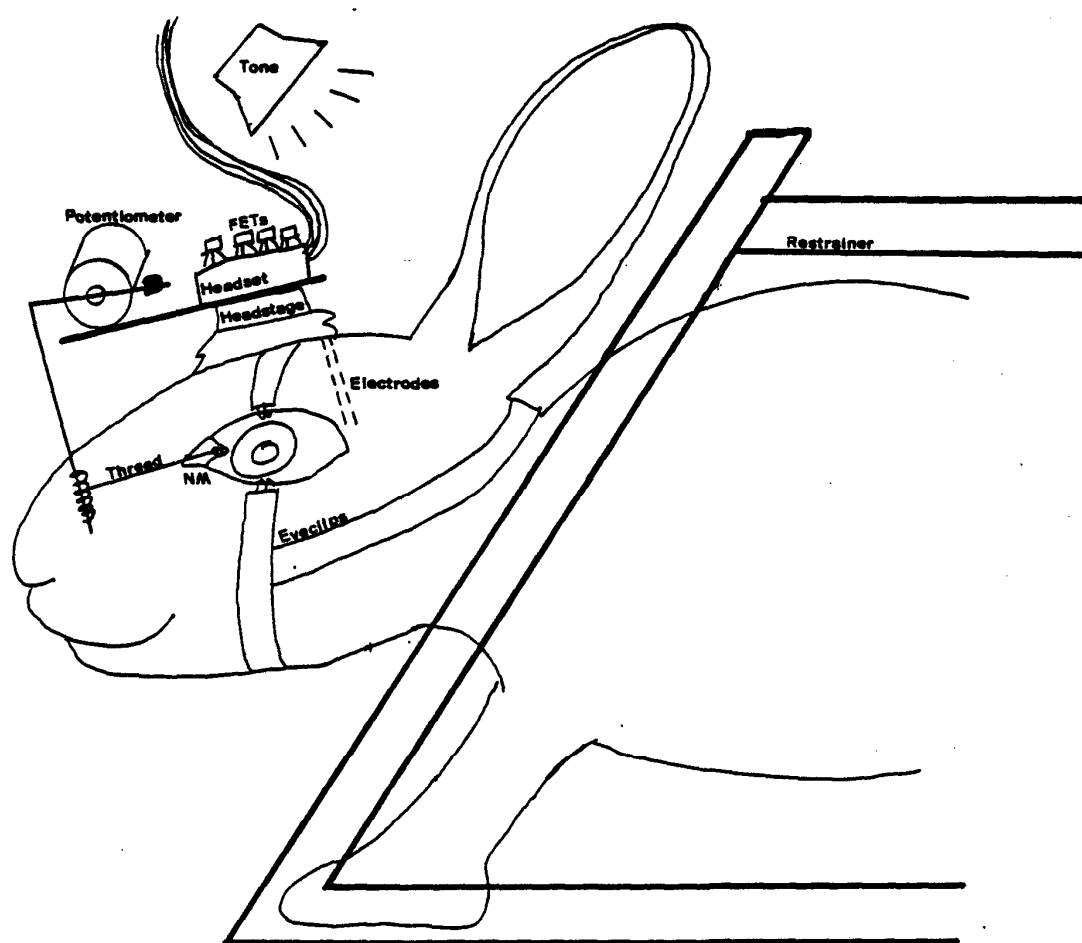

Figure 1 Paradigm for classical conditioning of the nictitating membrane-eyelid response in the rabbit. The nictitating membrane (NM) is a third cartilaginous eyelid which extends from the front of the eye to the rear when the eyeball is retracted. The movements of this eyelid are recorded by connecting the wire wiper arm of a mini torque potentiometer to the NM by a thread. The external eyelids are held open by eyeclips. Neuronal recordings are obtained by chronic implantation of electrodes or through the use of a micromanipulator connected to a headstage-jack. A headset containing the field effect transistors (FETs) is connected to this headstage. Pairing of a 350 millisecond, 1000 Hz, 85 dB tone with a 100 millisecond, 2.1 N/cm<sup>2</sup> airpuff to the cornea causes the animal to learn the eyeblink response and to come to extend his NM after the onset of the tone, but before the onset of the airpuff. The airpuff outlet nozzle is not illustrated, but would normally be fixed just in front of the center of the animals left eye.

cornea measuring  $2.1 \text{ N/cm}^2$  (3 psi) at the source. The interval from the onset of the tone to the onset of the airpuff (interstimulus interval) was set at 250 msec. The 250 msec prior to the onset of the CS is referred to as the Pre-CS period and is used as a measure of spontaneous activity. The 250 msec after the onset of the CS and before the onset of the UCS is referred to as the CS period, whereas the 250 msec after the onset of the UCS is referred to as the UCS period. All animals were trained to perform the conditioned eyeblink response in daily sessions of 13 blocks, with each block consisting of one tone-alone trial followed by eight paired trials for a total of 117 trials per day. The intertrial interval for all training was pseudorandom and ranged from 20 to 40 seconds with a mean value of 30 seconds. A conditioned response was defined as movement of the NM 0.5 mm or greater within the interstimulus interval. The animals were said to have reached criterion performance upon exhibiting eight conditioned responses on any nine consecutive trials. In all experiments the animals were trained one day after the day on which they obtained this criterion. Some animals with chronic cerebellar recordings or cerebellar cortical aspirations were given one session of unpaired training consisting of 104 tone alone trials and 104 airpuff alone trials pseudo randomly intermixed.

Although the behavioral response measured in this paradigm was that of NM extension, the animals actually learn to perform a number of other movements. Thus by recording from various musculature of the face, I found that the conditioned response with corneal airpuff training to one eye involves a coordinated retraction of the eyeball (resulting in a largely passive extension of the NM) together with closure, or attempted closure of the external eyelids (the eyeclips hold these eyelids open), and a variable degree of contraction of the facial musculature, including in some animals not only the periorcular musculature, but also the nasal musculature involved in movements of the vibrissae and respiration. The contralateral eye typically develops the same responses but of much smaller amplitude and of greater interanimal variability. However, over the course of training, all of the components of the conditioned responses of both eyes show virtually perfect correlation, both in terms of amplitude and latency to onset (see Figure 2).

The neurons responsible for the neuronal control of the retraction of the eyeball appear to be located within the abducens and accessory abducens nuclei and innervate the retractor bulbi muscle of the eye<sup>46,100</sup>. The eyelid musculature (M. obicularis oculi) is innervated by the seventh (facial) nucleus<sup>59</sup>. During performance of the conditioned response, the

onset latency of the EMG activity of the obicularis oculi is the shortest, occurring on the average 29.5 (+/-8.2) msec before the NM extension. In an animal well trained under the conditions of the present study, NM extension has an average minimum onset latency of about 100 msec and the eyelid EMG about 80 msec after the onset of the tone<sup>190</sup>. Therefore throughout the remainder of this dissertation the term eyeblink response is used to refer to the extension of the NM and the attempted closure of the external eyelids.



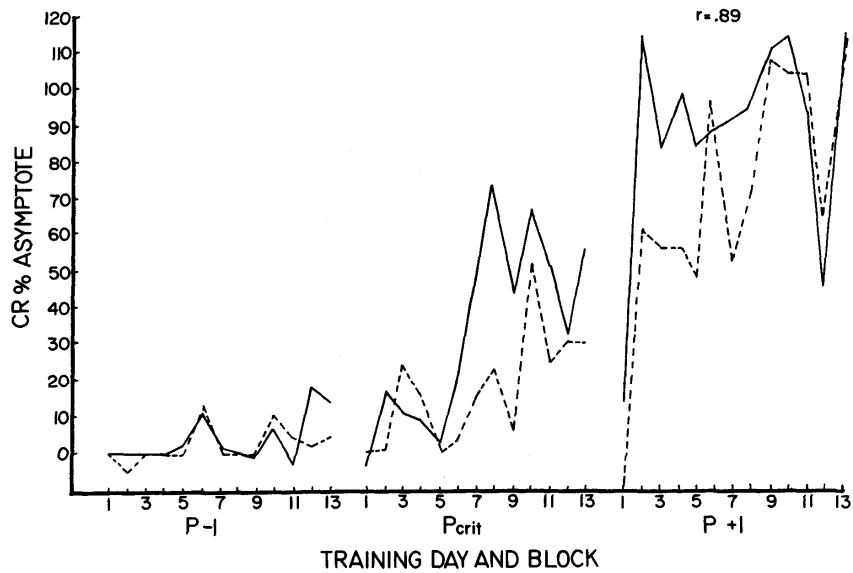
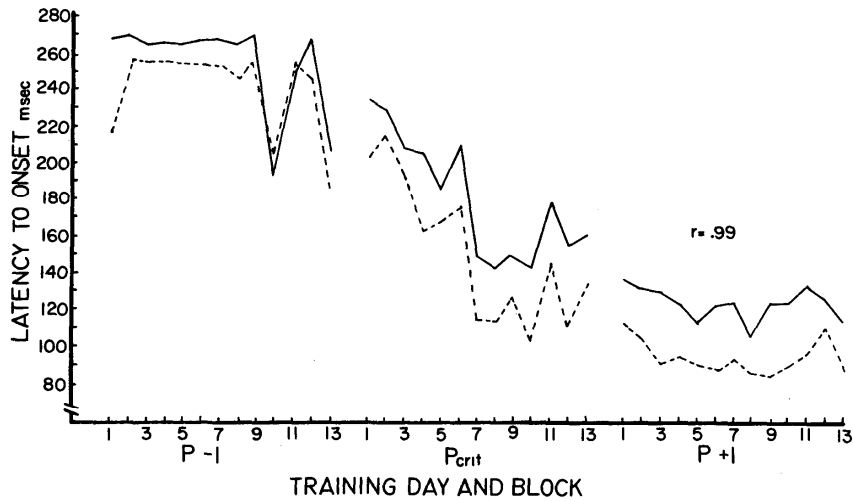

Figure 2 Comparison of learning rates of the left nictitating and the left and right eyelids. The top graph indicates the latency to onset after the onset of the tone of the movements of the left NM (solid line) and the EMG activity of the left external eyelids (dashed line). The interstimulus interval is set at 250 msec. Pcrit is the training day on which the animals reached criterion performance, while P-1 is the training day prior to, and P+1 is the training day just after, Pcrit. The correlation between the latency to onset for the left NM and left eyelids is very high (.99). The bottom graph illustrates the magnitude of the conditioned responses of the left NM (solid line) and the right eyelids (dashed line). CR%ASYMPTOTE is computed for each animal by dividing the amplitude of the conditioned response for the training block in question by the averaged amplitude of the conditioned response on the last six blocks of paired training. There is a significant correlation between the amplitude of the conditioned response of the left NM and of the right eyelids ( $r=.89$ ). The airpuff was delivered to the left eye only. Each block consists of nine training trials.

## CHAPTER 2 - GENERAL METHODS

### Surgery

Male New Zealand white rabbits weighing 2.0 - 2.5 kgs were used for the experiments contained within this dissertation. Before surgery, each animal was anesthetized with a mixture of flouthane gas (2-3%) and oxygen. The animal's skull was held in a custom stereotaxic head holder such that the top of the skull at lambda was 1.5 mm lower than that at bregma. After the implantation of the electrodes (lesion or record), or after aspiration of a particular portion of the cerebellum, a five pin socket headstage, to which the headgear and wires to the amplifiers were attached later during training, was secured to the animal's skull. A small loop of silk thread was sutured to the left nictitating membrane (NM) to allow measurement of the movements of this third eyelid. All animals were allowed five days (recording and electrolytic lesion studies) or seven days (cerebellar aspiration studies) of recovery after surgery before behavioral training began or resumed.

### Implantation of Dentate - Interpositus Electrodes

For the chronic recording study, two monopolar recording electrodes, with approximately 50 urn of tip (which tapered down to < 5 urn) exposed, were implanted simultaneously into the

region of the dentate-interpositus nuclei. The tips of the two recording electrodes were 1.0 - 2.0 mm apart in the medial-lateral plane. Positioning of the electrodes were according to the following coordinates - 0.0 to 1.5 mm anterior to lambda, 2.0 to 6.0 mm lateral from the midline, and 12.5 to 14.5 mm below the surface of the skull at lambda, using the atlas of McCormick and Thompson<sup>199</sup>. To assist further in the proper positioning of the electrodes, the unit activity was monitored on an oscilloscope and audio amplifier as the electrodes were lowered. The deep cerebellar nuclei could be distinguished from the cerebellar cortex by the lack of cellular layers and lower density of cell bodies. The electrodes were then secured to the skull with dental acrylic onto skull screws.

#### Micromanipulator Base for Acute Recordings

For the acute recordings, a hole approximately 5 mm in diameter was drilled through each animal's skull over the region of the ipsilateral cerebellum or brainstem to be recorded from and replaced with bone wax. A metal base to which the micromanipulator could later be attached was centered over the opening in the skull and secured with dental acrylic onto skull screws.

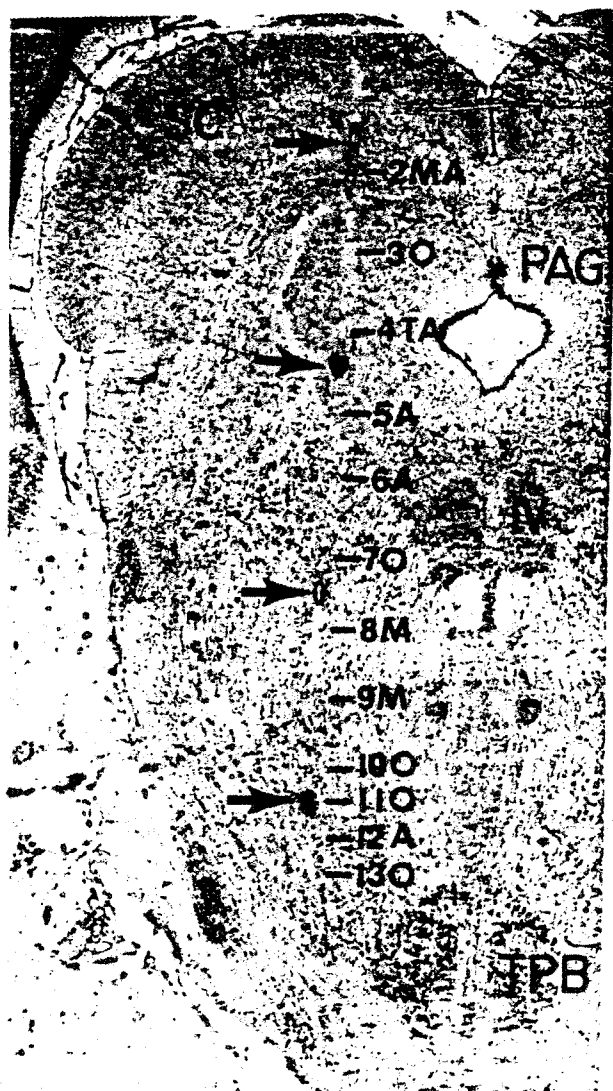

Figure 1 Histological reconstruction of a typical electrode tract. The arrows indicate each of four marking lesions made at intervals of 3 mm as the electrodes were removed from the brain. The numbers indicate the successive recording sites from which neuronal activity was recorded for a block of training trials. The letters beside each recording site refer to neuronal responses which appeared to be related to either the performance of the learned eyeblink response (M), the onset of the tone (T), or the onset of the airpuff (A) or to none of these (0). Abbreviations are as follows: PAG - periaqueductal gray, SC - superior colliculus, TPB - tegmental reticular nucleus of the pons, Bechterew, and IV - trochlear nucleus.

### Cerebellar Aspirations

Lesions of the cerebellar cortex were performed by aspiration under direct visual guidance. Care was taken not to disrupt the superior sagittal sinus or the transverse veins as doing so lead to the eventual death of the animal. The intracranial space caused by aspiration of the cortex was filled with gel foam and the hole in the skull was replaced with bone wax. Control animals also underwent surgery, although the skull was not opened and no lesion was made.

Removal of the intermediate and lateral cerebellar cortex (ansiform, paramedian lobules and paraflocculus) was found to give rise to only very minor, if any, motor disturbances immediately following the lesion, as has been reported previously<sup>147</sup>. Furthermore, if any motor deficit did occur (e.g. slight hyperflexion), this deficit disappeared over the course of the next few days. By the time that training began (one week) most of these animals were completely indistinguishable from normal, non-lesioned animals. Lesions of the mid-line cortex (anterior lobe, lobules a,b,c) were found to give rise to more pronounced motor difficulties than were seen with lesions of the lateral cerebellar cortex. These difficulties were most often

expressed as disequilibrium and discoordination of the limbs. For a more detailed discussion of the effects of cerebellar cortical lesions, see Chambers and Sprague<sup>48,49</sup>. In any event, the slight motor difficulties caused by the cerebellar cortical lesions did not appear to be related to the ability of the animal to retain or reacquire the conditioned eyeblink response.

### Electrolytic Lesions

All electrolytic lesions were performed under light halothane anesthesia.

The bipolar D-I electrolytic lesion electrodes were implanted according to the following coordinates: 0.0 and 1.0 mm anterior to lambda, 5.0 mm lateral to the midline, and 14.0 mm below bone at lambda. Electrolytic lesion of the D-I nuclei was performed by passing 2 mA DC for 2.5 min per electrode with the electrode as anode and scalp as cathode. Two of the animals were lesioned at 2 mA for 30 seconds in an attempt to define the effective lesion site more accurately.

A unipolar electrode for lesion of the superior cerebellar peduncle (SCP) was placed at the following coordinates: 3.5 mm anterior to lambda, 3 mm lateral to the midline, and 14.5 mm

ventral to bone at lambda. Bipolar electrodes for lesion of the middle cerebellar peduncle (MCP) or of the inferior olivary complex (10) were placed at the following coordinates: MCP - 4.5 mm anterior to lambda, 6.5 mm lateral to midline, 14.5 mm below bone at lambda; 10 - 0.5 mm anterior to 1.5 mm posterior to lambda, 0.5 and 1.5 mm lateral to the midline and 24.5 mm below bone at lambda. Electrolytic lesion of the SCP or the 10 was achieved by passing 2 mA DC for 15 seconds.

#### Neuronal Data Collection and Analysis

For the animals with chronic recording electrodes within the D-I nuclei the unit activity was recorded on magnetic tape along with movements of the NM (frequency modulated) and synchronizing pulses denoting the onset of the trial as well as the onset of the CS and the UCS. In the animals for acute recordings, unit recording was on the second day after criterion performance was met, thus the animals were well trained at the time of neuronal recording. A micromanipulator containing four electrodes at the corners of a rectangular array 2 mm X 3 mm was used to obtain the neuronal recordings. The electrodes were simultaneously lowered in increments of 0.5 - 1.0 mm steps, stopping after each increment to record the unit data for a block of nine training trials. This continued until the electrodes left the cerebellum or brainstem, at which point the four electrodes were raised to

the last recording site which exhibited satisfactory unit activity for all four electrodes. At this point marking lesions (100 uA DC for 3 seconds) were made. The electrodes were then raised 2 mm and another set of marking lesions were made. This was repeated for a total of 3-4 sets of marking lesions, denoting the path of each manipulator electrode through the cerebellum or brainstem (see Figure 1). Only one set of recordings were taken from each animal.

For both chronic and acute recordings, the recorded data were later analyzed on a PDP 11/03 minicomputer using pulse height level discriminators to detect only the larger amplitude action potentials. The neuronal responses were summarized as a peri-stimulus histogram for each block of training trials. For the acute recording data, photographs of each histogram (and therefore each recording site) were taken and matched with the appropriate recording site as revealed through histology. For the chronic recording data, peri-stimulus histograms were also summarized for the total of each day of training. If a recording site contained a response within the CS period, an estimate of the latency to onset of this response and the corresponding NM response was made by measuring directly from the computer screen, and converting to msec. This method was felt to give a rough estimate with an accuracy of



approximately 10 msec. The onset of neuronal responses was defined as the first histogram bar which was above the background firing rate and continuous with the larger response in question. Occasionally, onset latencies were not measureable, particularly for smaller responses. In these cases, the onset latency was neither measured or estimated.

For the acute recording studies from the cerebellum, correlations were then performed between the unit onset latency and the NM onset latency for each recording site, in an effort to help determine which neuronal responses were most related to performance of the conditioned eyeblink response. The neuronal responses within the CS period were grouped into three classifications: those which significantly covaried ( $r \geq .62$ ) with the onset latency of the NM behavioral response; those which did not covary significantly; and those which did not covary significantly and had onset latencies within 50 msec after the onset of the tone. The first classification is thought to represent responses which are in some way related to the performance of the conditioned eyeblink response, while the responses of the last classification are more related to the occurrence of the tone than to the occurrence of the behavioral response.

The chronic recording data were further analyzed according to

the amplitude of the response by the standard scores method, as described previously<sup>12</sup>. Each 250 msec (Pre-CS, CS, UCS) period of each trial was further divided into 125 msec halves. This was done since most neuronal responses within the CS period which related to the occurrence of the conditioned response, occurred within the second half of this period. Mean number of action potentials counted were computed for each 125 msec period. As a measure of variation of the spontaneous firing rate, a grand mean and standard deviation were computed for counts in the Pre-CS periods across each training session. Standard scores were then computed according to the following equation:

$$(\text{mean}(\text{CS}_{\text{block}}) - \text{mean}(\text{PreCS}_{\text{block}})) / (\text{SDPreCS}_{\text{session}}).$$

### Stimulation

Before perfusion, each recording site was marked by passing direct current (DC) of 100 uA for three seconds. This current deposits iron particles from the stainless steel electrode tip which can later be stained with a potassium ferrocyanide reaction. In a few of the animals it was noticed that the onset of this stimulation produced discrete ipsilateral eyeblinks. Therefore, to study this phenomenon further, future animals were stimulated after completion of behavioral training with a 60 Hz AC stimulus of 150 msec in duration and ranging from 5 uA to 300

uA. The behavioral responses of the animals varied from no observable response to postural adjustments, head movements, eye movements, movements of the vibrissae, movements of the forelimbs or hind limbs, ear movements, and eyelid closure along with NM extension. Eyelid closure and NM extension was elicited in isolation from other movements in a number of instances, while in other cases other bodily movements were also elicited in conjunction with the eyelid closure (e.g. head turning, postural adjustments). It was noticed that most behavioral responses had an intensity threshold of approximately 30 uA, with 30-100 uA eliciting larger movements, but still of a relatively specific nature. Stimulation at higher intensities (> 200 uA) were found to give rise to movements involving a large number of muscles (e.g. forelimb-hind limb movements, postural adjustments, head turning, eye movements, facial movements, etc.) if the electrodes were localized within the deep cerebellar nuclei. Therefore, a criterion for whether or not a recording site elicited an eyeblink was set at 100 uA AC or the onset of the 100 uA of direct current. This criterion is meant to indicate whether or not the general region of the recording site contained neural elements which when activated would elicit eyelid closure and NM extension.

### Histology

All animals were sacrificed with an overdose of sodium pentobarbital (Nembutal) and perfused through the heart with 10% formalin. Their brains were removed, embedded in albumin, and sectioned at 80 um on a freezing microtome. The sections were stained with a standard Nissl stain, cresyl violet, and with potassium ferrocyanide for the marking lesions. For the acute recordings, a reconstruction of the recording sites was made upon photomicrographs of the actual electrode path.

#### References for Methods

- Berger, T.W. and Thompson, R.F. Brain Res. 145 (1978) 323-346.
- McCormick, D.A., Lavond, D.G., and Thompson, R.F. Physiol. Behav. 28 (1982) 769 - 775.
- McCormick, D.A., Lavond, D.G., Thompson, R.F. Brain Res. In Press.

CHAPTER 3 - THE EFFECT OF CEREBELLUR LESIONS ON THE CLASSICALLY  
CONDITIONED EYEBLINK RESPONSE

Cerebellar Ablation

In order to test the possibility that the cerebellum is critically involved in the production of the learned eyeblink response in the rabbit, large aspirations of the ansiform, paramedian lobules along with the dentate-interpositus (D-I) nuclei of the cerebella of six animals was performed after all of these animals had been well trained (see Figure 2). The average number of trials to reach criterion before the aspiration was  $93.7 \pm 44.0$  (mean + SD). The ipsilateral (left) ablation of the lateral cerebellum permanently abolished the conditioned eyeblink response (see Figure 1 and 3). This effect is of course statistically significant ( $F(4,20) = 39.6; P < 0.001$ ). However, ablation had no effect at all on the amplitude of the unconditioned reflex response to the airpuff ( $F(4,20) = 2.38; NS$ ). Three of the six animals were then shifted to training of the other (right) eyelids and learned the response very rapidly. The number of trials to criterion performance was  $17.0 \pm 14.8$ , which is significantly less than for the original learning of the left side ( $t = 3.3; df = 8; P < 0.01$ ). The animals were then shifted back to training of the left eye and

again showed no learned responses (see Figure 3). Furthermore, if the cerebellar ablation is performed in naive animals (see Figure 4) before behavioral training, the animals never learn the response on the side of the lesion, although when training is switched to the eyelids contralateral to the lesion, the response is learned normally (see Figure 4).

#### Bilateral Cerebellar Ablation

It is a possibility that the cerebellar lesions abolish the learned eyeblink response through an asymmetrical disruption of some neuronal structure efferent from the cerebellum (e.g. the "Sprague effect"<sup>263</sup>). To test this hypothesis, one animal received a bilateral ablation of the cerebellum after training on both sides. The lesion was found to abolish the learned eyeblink on both sides. Furthermore, the learned eyeblink response did not recover despite repeated training efforts containing a total of 2640 trials (learned before the lesion in < 90 trials) over a three month period, thereby indicating that a symmetrical disruption of the output of the cerebellum does not reinstate the performance of the conditioned response. Furthermore, these data indicate that recovery of the ability to perform the learned response does not occur.

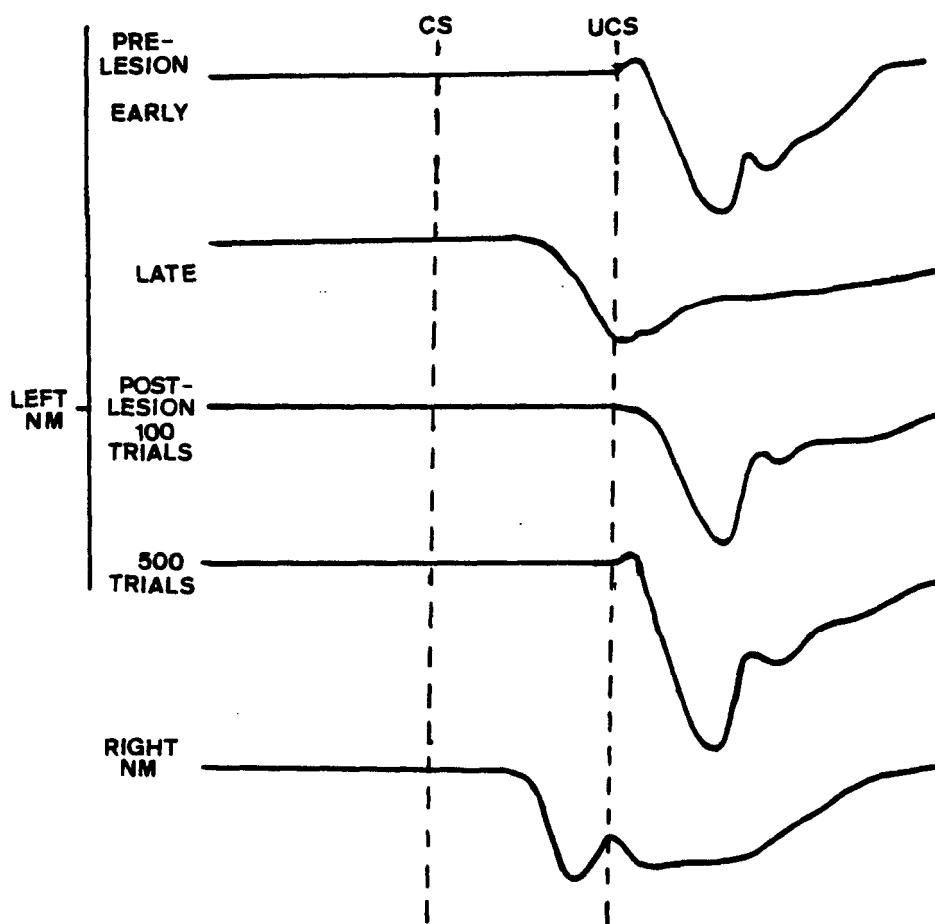

Figure 1 Examples of the effect of lesions of the lateral cerebellum including the dentate-interpositus nuclei on the conditioned eyeblink responses. Tracings are examples of the movements of the nictitating membrane both before and after lesion of the ipsilateral (left) cerebellum. Note that the conditioned eyeblink is abolished by the lesion while the unconditioned reflexive eyeblink in response to the corneal airpuff remains normal. This effect persists even after 500 trials of post lesion training. Furthermore, the contralateral NM-eyelid is found to learn rapidly when the airpuff is directed at this eye.

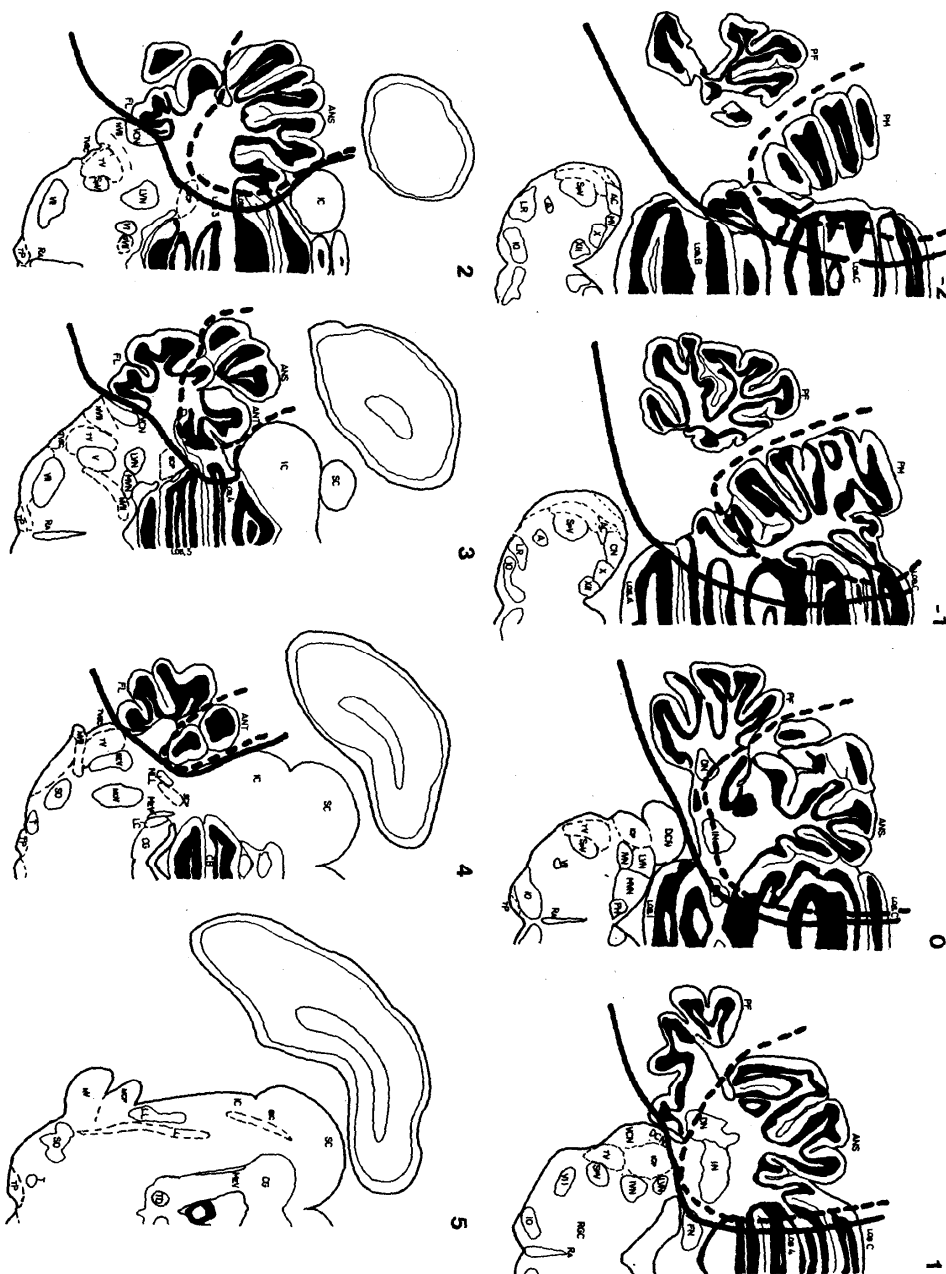

Figure 2 Reconstruction of the smallest and largest aspirations. All tissue encompassed by the dashed line was removed in the animal with the smallest aspiration, and all tissue encompassed by the solid line was removed in the animal with the largest aspiration. Numbers represent millimeters anterior to lambda with the top of the skull at lambda 1.5 mm lower than that at bregma. ANS - ansiform lobule, ANT - anterior lobe, DCN - dorsal cochlear nucleus, DN - dentate nucleus, FL - flocculus, FN - fastigial nucleus, IC - inferior colliculus, ICP - inferior cerebellar peduncle, IN - interpositus nucleus, MCP - middle cerebellar peduncle, PF - paraflocculus, PM - paramedian lobule, SCP - superior cerebellar peduncle, VCN - ventral cochlear nucleus.



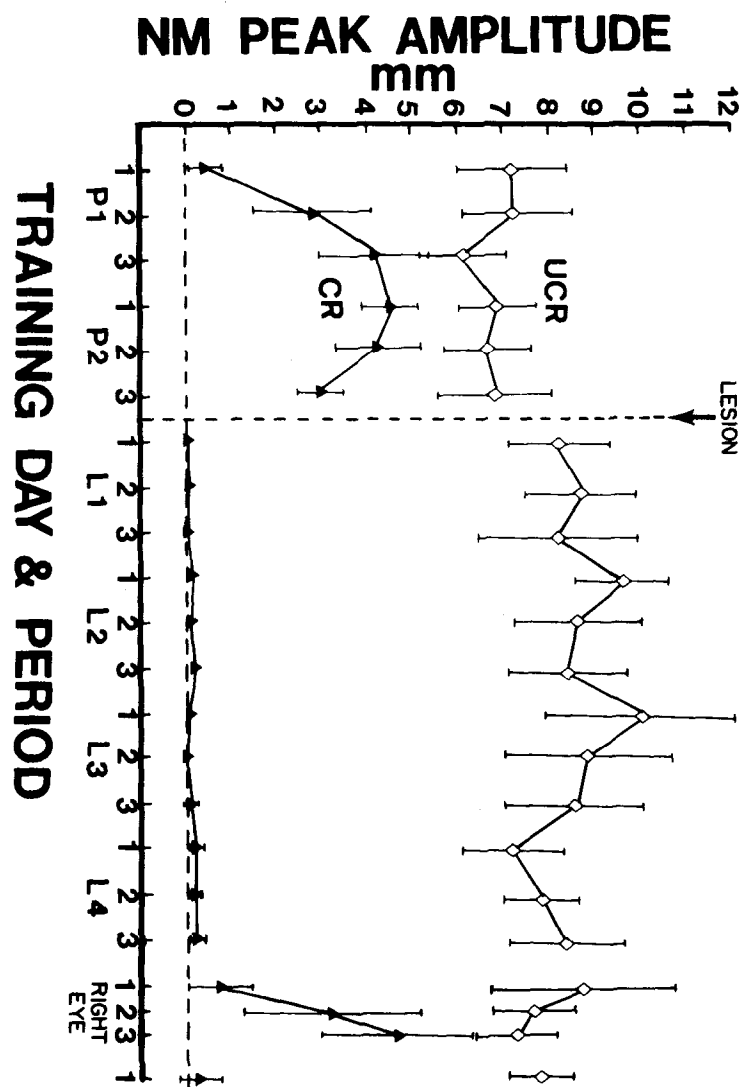

Figure 3 Effects of ablation of left lateral cerebellum on the learned NM/eyelid response (six animals). Solid triangles, amplitude of conditioned response (CR); open diamonds, amplitude of unconditioned response (UCR). All training was to left eye (ipsilateral to lesion) except where labeled "right eye." The cerebellar lesion completely and permanently abolished the CR of the ipsilateral eye but had no effect on the UCR. P1 and P2 indicate initial learning on the two days prior to the lesion. L1-L4 are four days of postoperative training to the left eye. The right eye was then trained and learned rapidly (right eye). The left eye was again trained and showed no learning. Numbers on abscissa indicate 40-trial periods, except for "right eye" which are 24 trial periods.

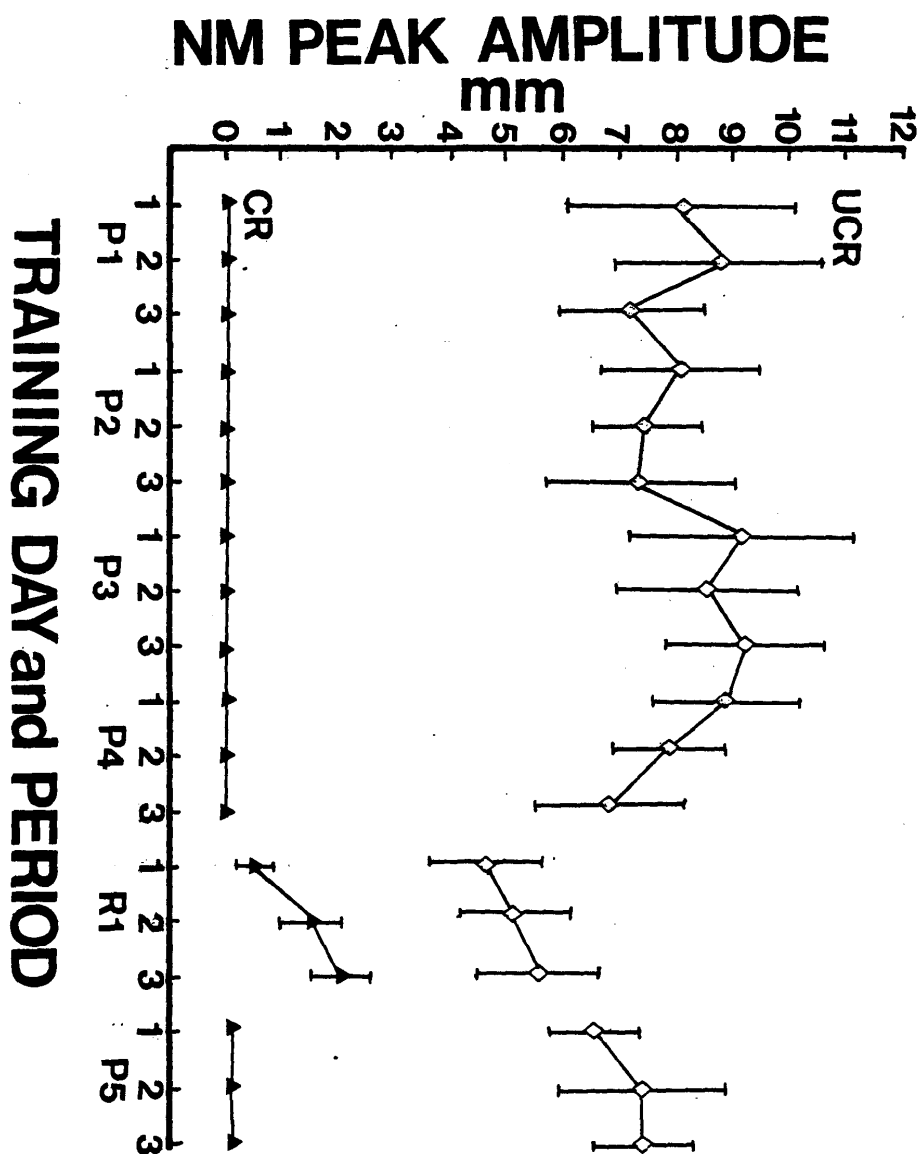

Figure 4 Effect of ablation of left lateral cerebellum on learning of the nictitating membrane (and eyelid) responses (6 animals). Solid triangles, amplitude of conditioned response (CR); open diamonds, amplitude of unconditioned response (UCR). All training was to the left eye (ipsi-lateral to lesion) except were labeled R1. The cerebellar lesion prevented conditioning of the ipsilateral eye but had no effect on the UCR. P1-P4 indicate the 4 days of post-lesion training to the left eye. The right eye was then trained and learned at a rate comparable to that of initial learning of non-lesioned animals. The left eye was again trained (P5) and showed no learning. Numbers on abscissa indicate 40-trial blocks.

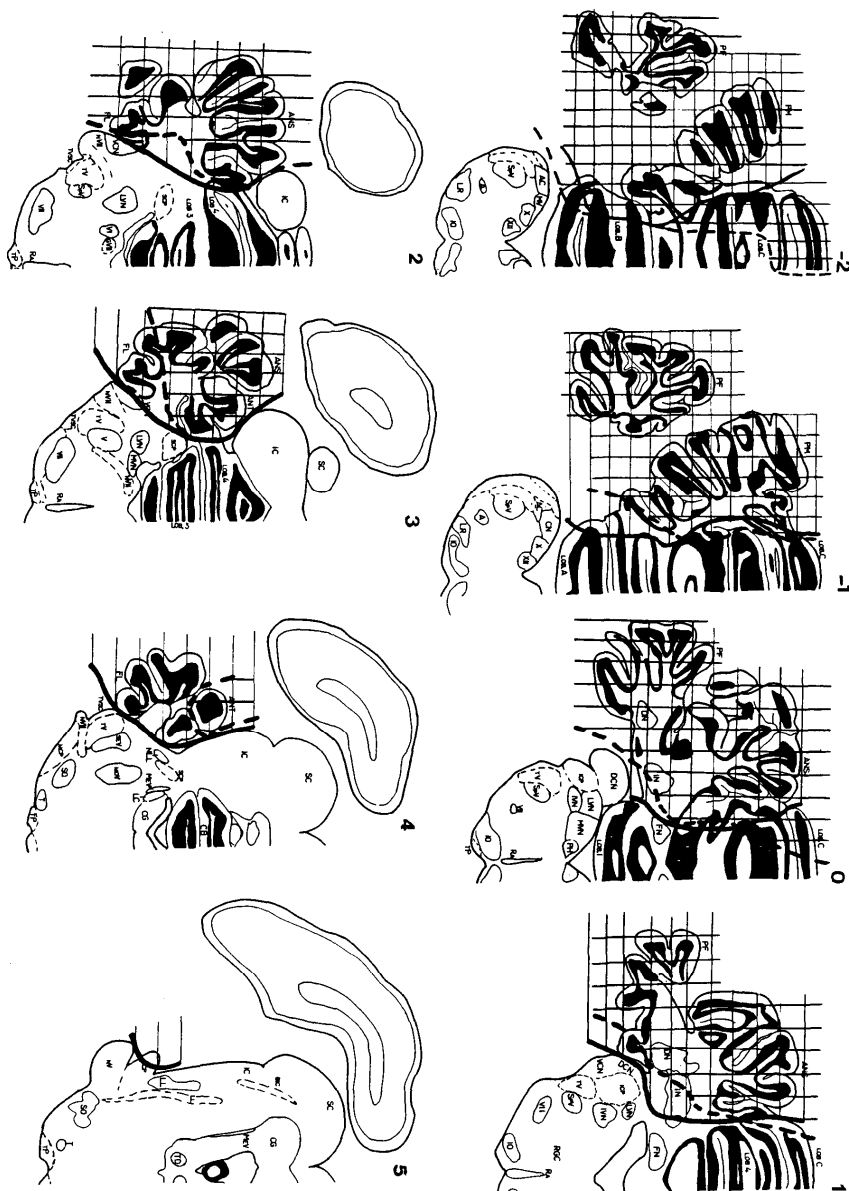

Figure 5 Reconstructions of the smallest and largest aspirations. All tissue encompassed by the dashed border and vertical lines was removed in the animal with the smallest aspiration. All tissue encompassed by the solid border and the horizontal lines was removed in the animal with the largest aspiration. The number above each section represents millimeters anterior to lambda with top of the skull at lambda 1.5 millimeters lower than that at bregma. The abbreviations relating to areas within or near the lesions are: ANS - Ansiform lobule, ANT - Anterior lobe, DCN - dorsal cochlear nucleus, DN - dentate nucleus, FL - flocculus, FN - fastigial nucleus, IC - inferior colliculus, ICP - inferior cerebellar peduncle, IN - interpositus nucleus, MCP - middle cerebellar peduncle, PF - paraflocculus, PM - paramedian lobule, SCP - superior cerebellar peduncle, VCN - ventral cochlear nucleus.

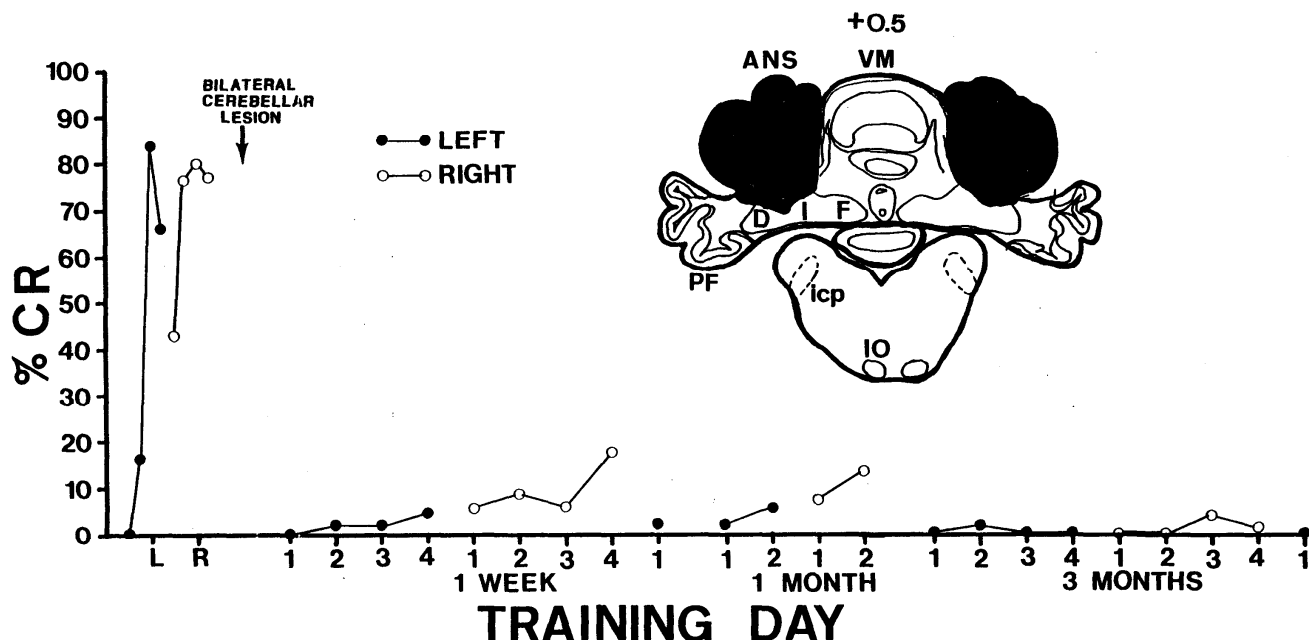

Figure 6 Effects of bilateral neocerebellar lesion on the conditioned eyeblink response of one animal. Before lesion, the animals left NM/eyelid was trained (L), with subsequent training of the right NM/eyelid (R). Each data point is an average of 30 trials. A bilateral cerebellar aspiration was performed and the animal was allowed to recover one full week. The animal was then given four sessions of training (120 trials per session) to the left and then right NM-eyelid followed by one additional day of training on the left. At one month post-lesion the animal was again trained two days on each side. At three months post-lesion the animal again received four sessions of training per side followed by one final day on the left. Each data point after (L) and (R) represent one full session of training. Histology revealed that the ansiform-paramedian lobules and the dorsal aspect of the dentate-interpositus nuclei were removed bilaterally. Note that although the animal learned the response initially in less than 90 trials, subsequent training of 1440 trials on the left and 1200 trials on the right over a period of 3 months failed to reinstate this learned response.

### Dentate and Interpositus Lesions

Note: This work was done in collaboration with Dr. Gregory Clark. To test the possibility that lesions of the dentate-interpositus (D-I) nuclei alone would be sufficient in abolishing the learned response, local, electrolytic lesions of these nuclei were made through previously implanted electrodes after learning of the eyeblink response had occurred. It was found that lesion of the dentate and interpositus nuclei and surrounding fibers caused complete or near complete abolition of the learned response ( $F(1,20) = 59.71; P \ll 0.001$ ), but had no effect on the unconditioned response to the airpuff. When training was switched to the right (non-lesioned) side, the animals learned the eyeblink response quickly, reaching criterion by trial thirteen, which was significantly faster than for original learning on the left side before the lesion (104 trials,  $F(1,12) = 33.7; P \ll 0.001$ ) (See Figure 7). Since a number of these electrolytic lesions incorporated portions of the cerebellar cortex above the D-I nuclei (anterior and paramedian lobules), this cortical region was aspirated after learning in an additional 5 animals. These aspirations caused no significant change in the amplitude of the conditioned response, ( $F < 1; NS$ ), although there were occasional changes in the amplitude-time course of the conditioned eyeblink response.

Table 1. Effects of unilateral lesions of cerebellar nuclei on mean conditioned and unconditioned NM responses of the ipsilateral eye for experimental (Exp; n = 14) and control (Con; n = 8) lesion animals.

Response Measure	Pre-lesion	Post-lesion	F
CR amplitude	5.3 mm	0.6 mm	59.7***
(Exp) CR	4.8 mm	5.3 mm	<1
amplitude (Con)			NS
UR amplitude (Exp)	7.6 mm	7.3 mm	<1
			NS
UR amplitude (Con)	7.9 mm	9.3 mm	2.49 NS
Percent CRs	97.3%	29.9%	154.3**
(Exp) Percent	97.3%	90.2%	* <1
CrS (Con)			NS

---

\*\*\*p < .001, NS = significant  
not

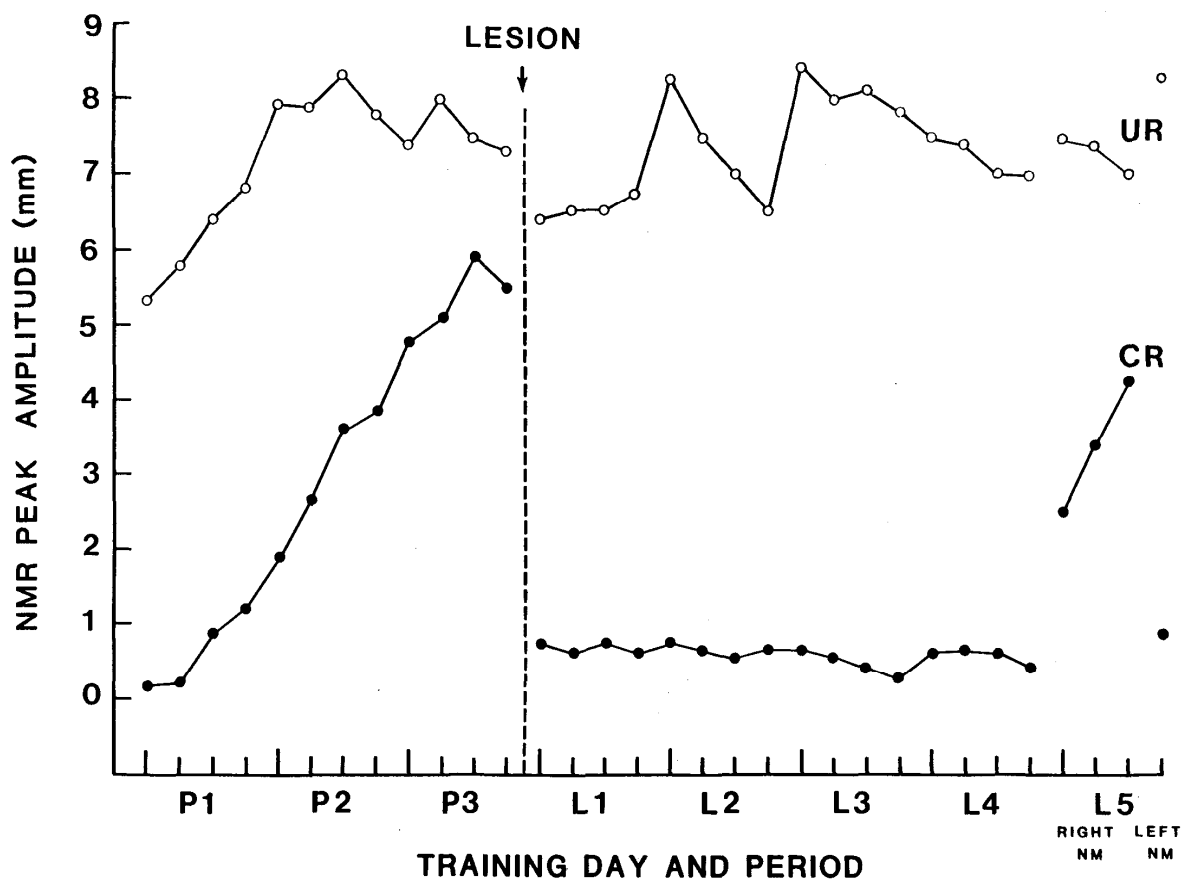

Figure 7 Effects of unilateral lesions of cerebellar nuclei on conditioned and unconditioned nictitating membrane (NM) responses (mean amplitude,  $n = 14$ ). Animals received three days of training (P1-3) on the left eye prior to lesioning. After lesioning, (left cerebellar nuclei), animals were trained for four days ( $L1 > 4$ ) to test for retention and recovery of the conditioned responses. On the fifth post-lesion session (L5), training was switched to the right (nonlesioned) side, then returned to the left eye ( $n = 13$ ). Results of each training day are represented in four periods of trials, approximately 27 trials per period. Note that CR amplitude was almost completely abolished by the lesion, but UR amplitude was unaffected. Note also the right (non-lesioned) side learned quickly, controlling for non-specific lesion effects, but that conditioned responding on the left side showed essentially no recovery.

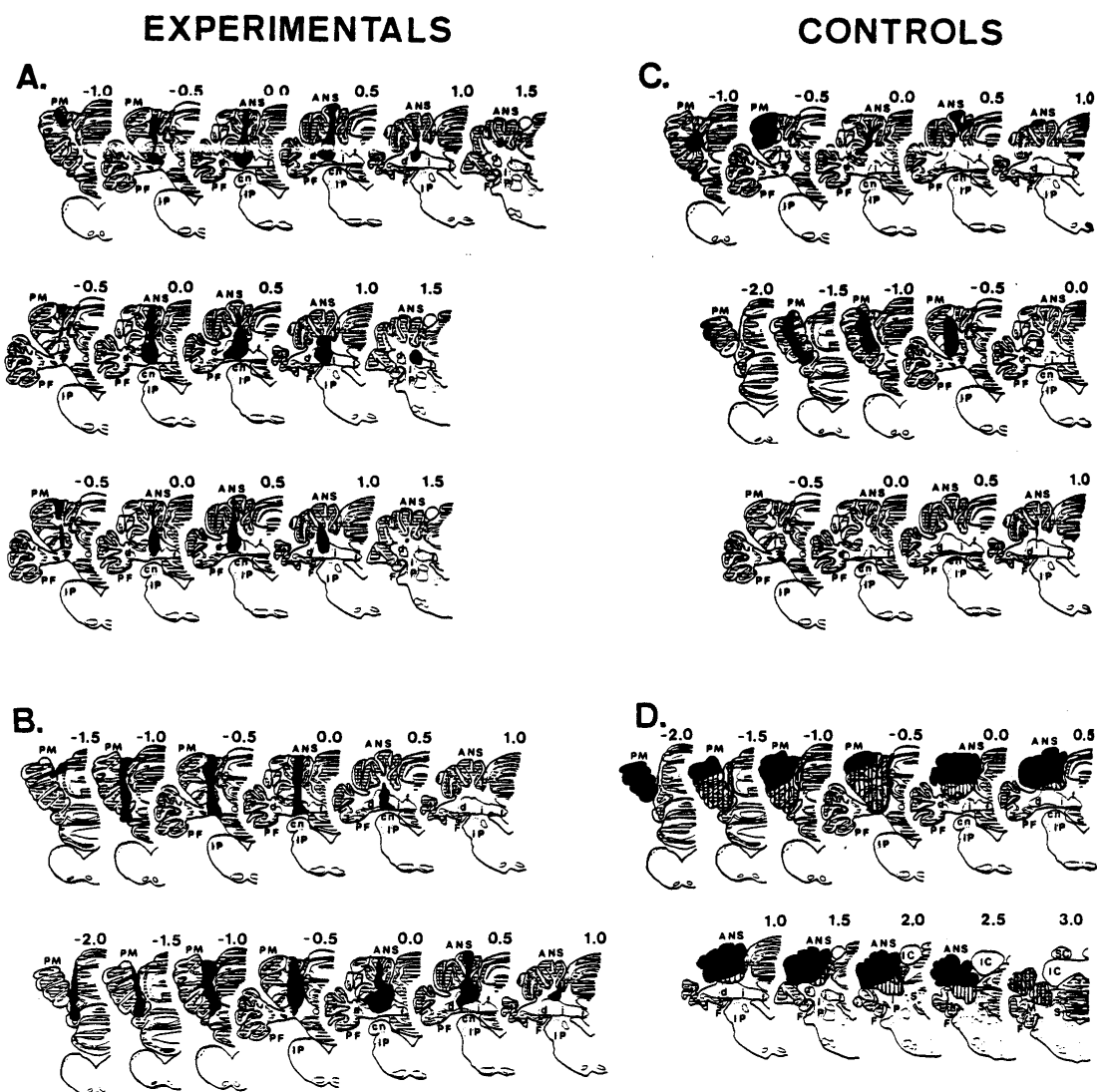

Figure 8 Histological reconstructions of electrolytic cerebellar lesions in experimental (A and B) and control (C and D) animals. A and B: Lesions in experimental animals with the three largest (A) and two smallest (B) decreases in CR amplitude after lesion. Numbers above sections refer to mm posterior (negative numbers) or anterior (positive numbers) to lambda; darkened area represents lesion. C: Lesions in three electrolytic control animals. Lesions entirely spared cerebellar nuclei in three of the four controls (e.g., top two animals); damage to nuclei in the fourth animal (bottom row) was confined to the path of the electrode, which passed out of the cerebellum. D: Reconstruction of cortical aspirations. Darkened area: extent of aspiration common to all four animals; vertical stripes: maximum extent of aspiration. Key: ANS, ansiform lobule; en, cochlear nucleus; d, dentate nucleus; f, fastigial nucleus; F, flocculus; i, interpositus nucleus; IC, inferior colliculus; IP, inferior cerebellar peduncle; PF, paraflocculus; PM, paramedian lobule; M, middle cerebellar peduncle; S, superior cerebellar peduncle.



Therefore, lesion of the D-I nuclei themselves is sufficient to abolish the learned eyeblink response. Figure 8 presents representative histologies of lesions of the D-I nuclei which were effective in abolishing the learned eyeblink response. The nuclear region incorporated within the boundaries of the lesion is often the medial dentate along with the lateral interpositus nuclei. However, since the axons from the D-I nuclei must course medially in order to form the superior cerebellar peduncle (SCP)<sup>199</sup>, it is entirely possible that the more lateral regions of the dentate nucleus may have also been involved within these lesions.

#### Lesions of the Superior Cerebellar Peduncle

Cerebellar lesions are known to cause retrograde degeneration of some of the afferents whose fibers are incorporated by the lesion (e.g. inferior olive and pontine nuclei). Therefore, it is a possibility that the cerebellar lesions may have their effect through retrograde changes in some neuronal population outside of the cerebellum. Therefore, lesions of the SCP (the SCP is the major output pathway of the D-I nuclei) were performed in an additional 5 animals and these animals were tested within 24 hours of the lesion. Lesions of the SCP would not lead to retrograde changes in neurons lying outside of the cerebellum within this short period of time. SCP

lesion was found to abolish or drastically reduce the amplitude of the conditioned response (CR) over the four days of post-lesion training as compared with the CR amplitudes of the day prior to the lesion ( $F(19,76) = 7.8$   $p < .001$ ), without effecting the amplitude of the UCR ( $F=.59$  NS). When shifted to training of the right NM-eyelid, all animals learned the response very rapidly, with the average trials to criterion being  $15.8 \pm 8.6$ ; significantly less than for original acquisition of the left side ( $t=3.3$   $df=8$   $p<.05$ ). An additional animal whose lesion was medial to the SCP (see Figure 10) showed no effect of lesion on the amplitude of the ipsilateral CR ( $7.7 \pm 3.8$  mm before lesion,  $7.6 \pm 1.6$  mm after lesion). Thus, lesion of the SCP is found to abolish or severely impair the ipsilateral, but not the contralateral, CR.

The extent of the lesion for each animal is reconstructed in Figure 10. The lesions of five of the six animals are seen to encompass a significant portion of the SCP as it leaves the body of the cerebellum and enters into the brainstem. The CRs of all five of these animals were abolished or severely impaired after the lesion (see Figure 9). Other cell groups were also occasionally disrupted. These cell groups included the superior vestibular nucleus ( $n=3$ ), the lateral vestibular nucleus ( $n=2$ ), the nucleus of the lateral lemniscus ( $n=2$ ), and lobes 3 and 4 of

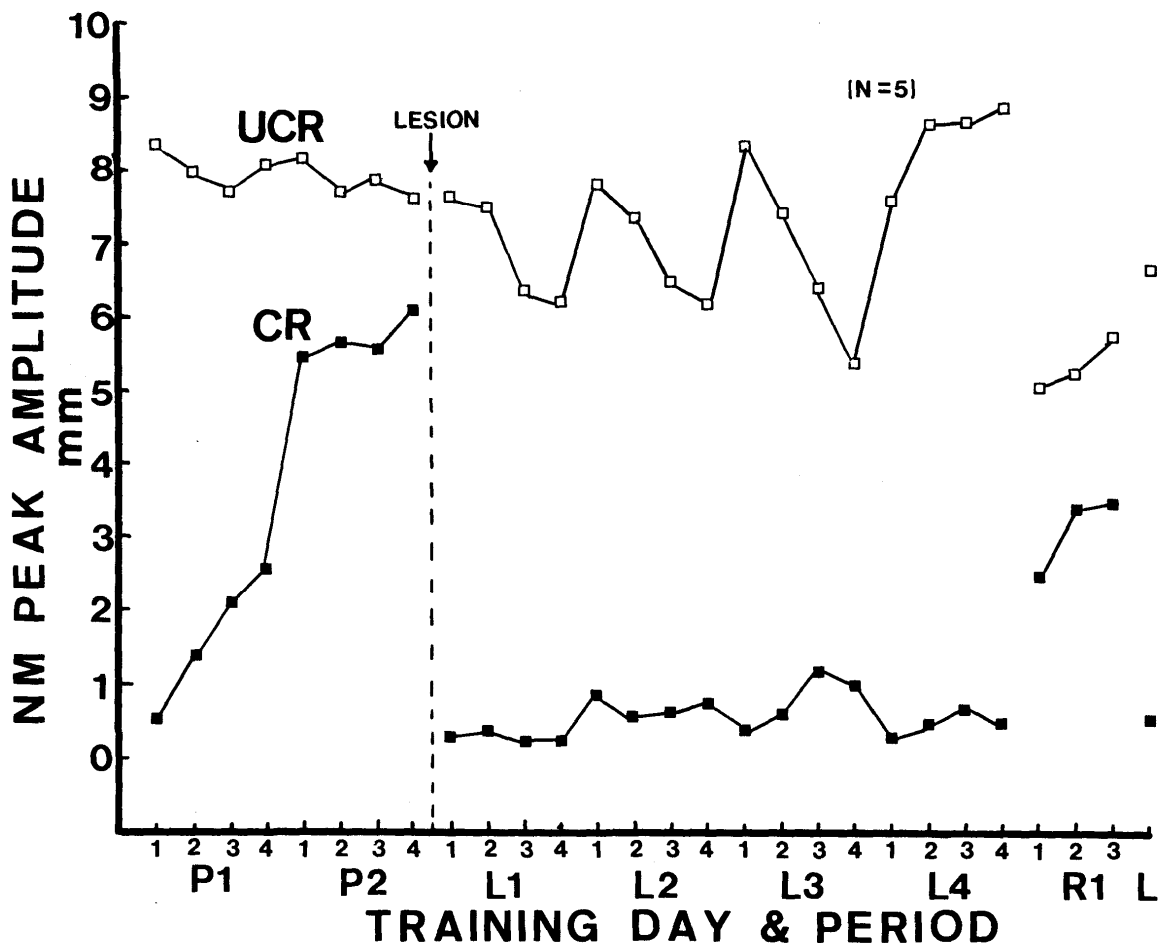

Figure 9 Effect of lesion of the ipsilateral superior cerebellar peduncle (SCP) on retention and reacquisition of the nictitating membrane (and eyelid) responses, averaged for five animals. Solid squares, amplitude of conditioned response (CR); open squares, amplitude of unconditioned response (UCR). All training was to the left side except where labeled R1. The lesion abolished or severely impaired the ipsilateral CR with no effect upon the UCR. P1-P2 indicate the two days of training prior to the lesion. L1-L4 indicate the four days of training after the lesion. The contralateral (right) eye was then trained and learned quite rapidly (R1). The left eye was again trained (L) and still showed only very small responses. Numbers on abscissa represent approximately 27 trial blocks.



Figure 10 Reconstructions of the electrolytic lesions of all six animals. Part A represents the course of the superior cerebellar peduncle (SCP) as it leaves the cerebellum and enters the brain stem. The number above each section is the level of the section in millimeters anterior to lambda. The calibration bar in the lower left represents one millimeter. Part B is the lesion reconstructions of the five animals exhibiting substantial damage to the SCP. The number above each set is the animal's identification number. Part C is a photomicrograph of the lesion of animal number 439. Part D is the lesion reconstruction of an animal whose lesion mostly spared the SCP (it damaged only the most medial part) and had no effect upon the ipsi-lateral CR. Abbreviations of structures near the SCP for part A are as follows -- ANT- anterior lobe of the cerebellum, LC- locus coeruleus, LVN- lateral vestibular nucleus, MeV- mesencephalic fifth nucleus, MVN- medial vestibular nucleus, NLL- nuclei of the lateral lemniscus, SCP - superior cerebellar peduncle, SV- superior vestibular nucleus.

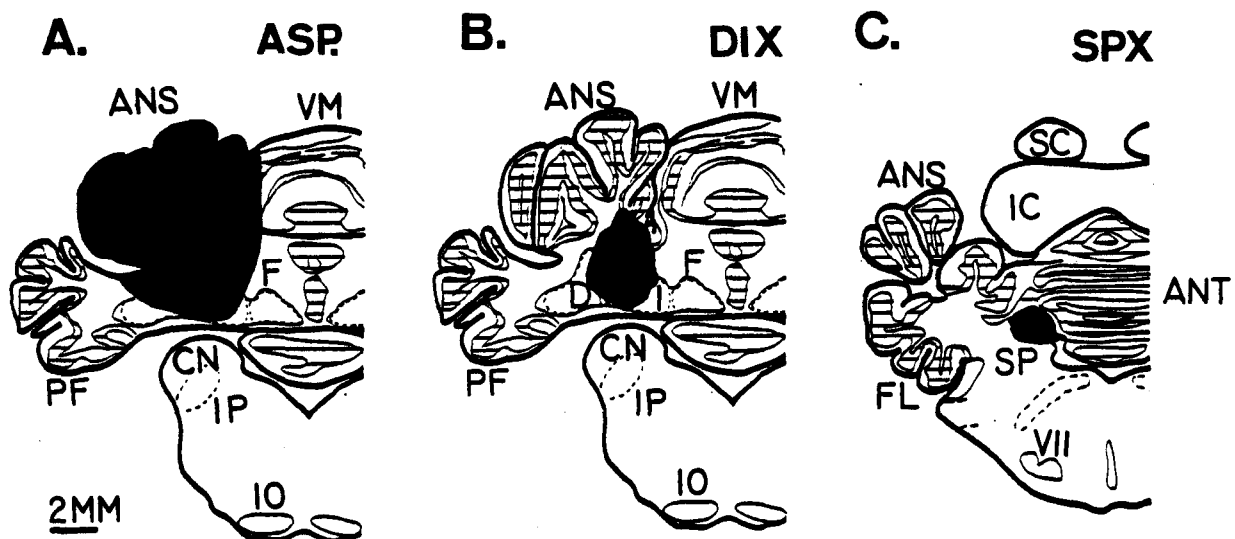

Figure 11 Reconstructions of cerebellar lesions effective in abolishing the ipsilateral conditioned eyeblink response. A: typical unilateral aspiration of the lateral cerebellum and dentate-interpositus nuclei. B: a unilateral electrolytic lesion of the dentate-interpositus nuclei (DIX) in which the overlying cortex is spared. C: a localized unilateral lesion of the superior cerebellar peduncle (SPX). All reconstructions are through the broadest extent of each lesion. Abbreviations are as follows: ANS - ansiform lobule, CN - cochlear nucleus, D - dentate nucleus, F - fastigial nucleus, ANT - anterior lobe, FL - flocculus, I - interpositus, IC - inferior colliculus, IO - inferior olive, IP - inferior cerebellar peduncle, PF - paraflocculus, SC - superior colliculus, SP - superior cerebellar peduncle, VM - vermal lobes, VII - seventh nucleus.

the cerebellum (n=1). However, the only region common to all animals was that of the SCP and any immediately adjacent reticular cells (and perhaps the uncinata fasciculus).

The SCP contains mainly efferent fibers from the D-I nuclei to brainstem and thalamic structures (e.g. red nucleus, ventral lateral thalamus). Although there are some afferents to the cerebellum contained within the SCP, the majority of these fibers are from the ventral spinocerebellar tract and are involved with the hind limbs and trunk only<sup>26</sup>. The present study therefore strongly suggests that the abolition of the conditioned response with large ablations and electrolytic lesions of the cerebellum also occurs with disruption of essential efferents from the cerebellum.

#### Lesions of the Cerebellar Cortex

The previous experiments have shown that the output of the D-I nuclei is critical for the production of the learned response. Since the cerebellar cortex projects heavily to the D-I nuclei, it is possible that these lesions are having their effects by disrupting the relaying of some critical output of the cerebellar cortex. A number of investigators have suggested that the cerebellar cortex may be capable of undergoing sufficient changes in neuronal function in order to store

"motor programs" or "motor memories"<sup>1,3,90,132,186</sup>. Therefore, a series of experiments were performed in order to test whether or not the cerebellar cortex is essential for the learning and retention of the classically conditioned eyeblink response.

#### Cerebellar Cortical Lesion after Learning

The results of the cerebellar cortical lesions after learning of the eyeblink response are summarized in Figures 12 and 13. In short, no cortical region was found which upon removal consistently abolished the learned eyeblink response. The following cortical regions were removed without abolishing the conditioned response: ansiform lobule (crus I and crus II, n = 7), lobulus simplex (n = 7), paramedian lobule (n = 6), paraflocculus (n = 3), lobule a - nodulus (n = 1), lobule b - uvula (n = 1), lobule c - medius medianus and pyramis (n = 5), and the anterior lobe (n = 5). The non-effective lesions also included complete destruction of the fastigial nucleus bilaterally and the lateral portions of the dentate nucleus (see Figure 15). The flocculus was not removed in any animal due to its inaccessible position in the cerebellum. Figure 15 illustrates the composite ineffective lesion sites as well as a stereotaxic lesion of a previous study<sup>52,53</sup> which was found to be effective in abolishing the learned eyeblink response. The ineffective lesions are found to surround the region of the

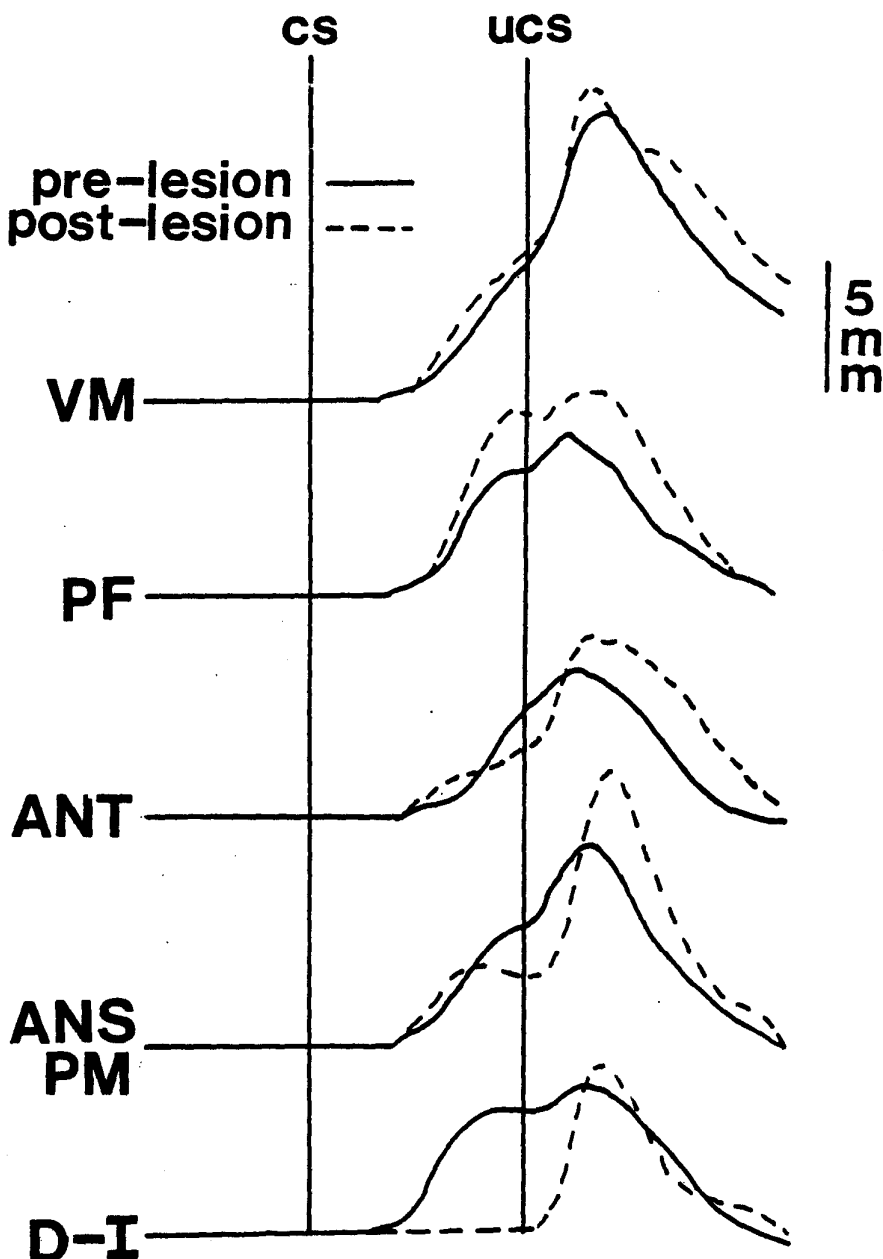

Figure 12 Averaged nictitating membrane (NM) responses before and after cerebellar cortical lesion. The solid trace represents the averaged response of all paired trials on the day before the lesion. The dashed line represents the averaged NM response on all paired training days (up to four) after the lesion. The first vertical line represents the onset of the tone, while the second vertical line represents the onset of the airpuff. All animals were placed into one of five groups: VM - lesions of the vermal (midline) cerebellum, PF - lesions of the paraflocculus, ANT - complete removal of the anterior lobe, ANS/PM - lesions of the ansiform-paramedian lobules, D-I - lesions which contained a significant portion of the medial dentate-interpositus nuclei.



effective lesion; this effective region being the medial dentate and lateral interpositus nuclei.

In two animals the ansiform, paramedian, and paraflocculus regions of the cerebellar cortex were successfully removed. In one of these animals (number 5) the learned response was abolished and did not recover over four days of training (see Figure 13) as reported previously<sup>191</sup>. However, replication of this lesion in animal 13 (Figure 13) failed to abolish the learned response, although the response was reduced on the first day after the lesion. The learned response in one additional animal with removal of lobule c of the midline cortex was also abolished, although similar lesions in 2 additional animals also failed to abolish the learned response. In three animals the cortical lesions extended well into the region of the dentate-interpositus nuclei. As expected, the learned eyeblink response of all three of these animals was completely abolished and did not recover over the four days of post-lesion training (see Figure 12), thus replicating our earlier reports<sup>189,191</sup>.

As mentioned above, the ansiform lobule was removed, along with varying degrees of damage to the paramedian lobule in 7 animals without significantly affecting the amplitude of the conditioned response (conditioned response peak amplitude pre-lesion  $X = 5.0 \pm 1.7$  mm, post -lesion  $X = 4.1 \pm 2.3$  mm,  $t =$

1.4 NS). However, the unconditioned response was significantly larger after removal of the ans-pm lobules (pre-lesion peak amplitude  $X = 8.25 \pm 1.25$  mm, post-lesion  $X = 11.8 \pm 3.5$  mm,  $t = 3.2$   $df = 7$ ,  $p < .05$ ). This increase in response to the corneal airpuff may have its basis in the fact that lesions of the cerebellar cortex are known to lead to hyperflexion and exaggerated flexor responses in the cat<sup>308,309</sup>. Furthermore, cooling of the cerebellar cortex is also known to increase the responsiveness of interpositus neurons to stimulation of its inputs<sup>245,308</sup>. Involvement of the dentate-interpositus nuclei in unconditioned eyeblink responses has been hypothesized by McCormick and Thompson on the basis of recording and stimulating results<sup>198</sup>, although lesions of the dentate-interpositus nuclei show that this contribution is not critical for a normal unconditioned response to be performed<sup>191</sup>. Alternatively, the increase in the reflexive eyeblinks may be due to the fact that in the animals with lesions of the ans-pm lobules, the NM is not extended to protect the cornea at the onset of the airpuff as well as before the lesion was made. However, the fact that animals with no prior training and lesions of the ansiform and paramedian lobules do not differ significantly from controls in the amplitude or their unconditioned response to corneal airpuff (see below) indicates that the increase in UCR with animals given cortical lesions after training may be a general result of

training procedure. In support of this, it was found that the UCR increased slightly in 17 of the 20 animals with lesions of the cerebellar cortex after training, regardless of the region of the cerebellar cortex involved.

Perhaps a more interesting change in the amplitude-time course of the conditioned response was that in a number of animals, the ability of the animal to maintain eyelid closure during the performance of the conditioned response was significantly affected by lesions of the ansiform-paramedian (ans-pm) cortex (see Figure 13). This result, measured as the amplitude of the NM response at the onset of the UCS post-lesion versus pre-lesion, is statistically significant (Wilcoxon sign test,  $p < .05$ ). In three animals the eyelids were actually reopened before the onset of the airpuff; a response which is maladaptive and therefore is almost never seen in normal animals (compare post-lesion responses with pre-lesion responses, Figure 13). This type of alteration of eyeblink response was not seen any other type of lesioned or non-lesioned animal.

That the eyeblink responses to the tone in the ans-pm lesioned animals were actually conditioned responses, and not due to sensitization induced by the cerebellar cortical lesion, is evidenced by the fact that naive animals with similar lesions did not differ from normal animals in sensitization during unpaired

presentations of the stimuli (see below).

Microscopic examination of the deep cerebellar nuclei revealed that after removal of a portion of the cerebellar cortex, there was a marked increase in the density of glial cells in a predictable portion of the dentate-interpositus nuclei, as compared to the contralateral, non-lesioned side. Presumably, this rise in number of glial cells represents the degeneration of cortico-nuclear (Purkinje) and nucleo-cortical projections<sup>50,134</sup>. We do not know what effect this process may have on the proper functioning of the dentate-interpositus nuclei.

Furthermore, it is known that degeneration of structures outside the cerebellum (e.g. pontine nuclei, inferior olive) may occur after removal of regions of the cerebellar cortex<sup>34</sup>. Thus we found in a few animals that portions of the inferior olivary complex possessed a marked loss of cell bodies on the side contralateral to the lesion. In the example shown in Figure 16, the animal suffered removal of the ansiform, paramedian lobules and the lateral most folia of lobule 4 of the anterior lobe. The inferior olivary complex was found to possess a marked decrease in cell density in the contralateral portions of the ventral and dorsal lamina of the principal olive, thus replicating earlier results obtained by Brodal<sup>26,24</sup>. From these results, it would appear that the cerebellar cortex is not necessary for

performance of the conditioned response and also that no afferent which would degenerate upon removal of the cerebellar cortex is necessary.

#### Cerebellar Cortical Lesions Before Training

The ansiform-paramedian lobules are the cortical regions which project to the medial dentate and interpositus nuclei<sup>28,62,63,95,96,134</sup>, i.e., the region of the cerebellar deep nuclei which is essential for the learning and retention of the conditioned eyeblink response<sup>52,53</sup>. Furthermore, removal of the ansiform-paramedian lobules after learning was found to alter the shape of the learned eyeblink response in some animals (see above). Therefore, we removed the ansiform-paramedian lobule in 8 animals to test the hypothesis that this region of cerebellar cortex may be more important for the learning, than for the retention, of the conditioned eyeblink response. The results are summarized in Figures 17, 18, and 19.

Of the eight animals with removal of the ansiform cortex, 4 learned the response at a normal rate within the four days of paired training, 2 failed to learn the response at all and 2 animals showed indications of learning the response, but were clearly deficient (see Figures 18 and 19). One of the animals which failed to learn the eyeblink response was found to possess

significant lesion damage to the dentate-interpositus nuclei, therefore replicating our earlier results<sup>173</sup>.

Since six of the eight animals had damage to the paramedian lobule, the paramedian lobule alone was completely removed in an additional two animals. Both of these animals learned the eyeblink response on the first day of training and were not significantly different from controls. In addition, five control animals (no lesion) were also trained. All five animals learned the response within the first two days of paired training (see Figure 17). There was no statistically significant difference between the learning rate of the three groups over the first two days of behavioral training ( $F = 1.3$  NS). The amplitudes of the unconditioned eyeblink responses to the corneal airpuff of the ans-pm group were not found to be significantly different from those of the controls (ans-pm -  $X = 10.7 \pm 2.2$  mm, non-lesions controls,  $X = 9.6 \pm 2.2$  mm,  $t = 1.2$  NS), nor from those of animals with removal of the paramedian lobule ( $X = 8.1 \pm 3.2$  mm).

Four of the animals with ansiform lesions and four control animals were also given one day of unpaired presentations of the tone and airpuff before paired training to test for possible sensitization effects. Neither the control group or the ans-pm group revealed significant sensitization to the tone during

unpaired presentations of the stimuli, thus removal of the ans-  
pm lobules did not increase the probability of developing  
sensitized responses to the tone ( $F = .13$  NS).

#### Summary of Cerebellar Lesion Effects

The previous studies have shown that lesions of the D-I  
nuclei or their output pathway, the SCP, permanently (tested up  
to 3 months) abolishes the classically conditioned eyeblink  
response in the rabbit. Furthermore, removal of the cerebellar  
cortex (flocculus not tested) is found not to have this effect.

Lesions of the D-I nuclei may abolish the learned response in  
four basic ways (see Figure 21). The lesion may: 1. remove the  
changes in neuronal function serving to encode the learned  
response; 2. prevent the expression of the learned response (i.e.  
block an essential efferent pathway); 3. prevent the neural  
activity elicited by the tone from reaching the site(s) of  
neuronal change encoding the learned response; 4. cause a  
critical malfunction in some other neural regions which are  
themselves one of the other choices (afferent to, at, or  
efferent to, the site(s) of neuronal change) by a change in  
tonic excitation and/or inhibition. Our data are most  
consistent with choices 1 and 2. The cerebellum is most likely  
not afferent to the essential changes in neuronal function

encoding the learned response since stimulation of the D-I nuclei can cause eyeblinks both before and after learning has occurred. Furthermore, recordings from the D-I nuclei have at times revealed changes in neuronal activity which correlate highly with the learning of the eyeblink response (see Chapter 4).

The abolition of the CR after D-I lesion is most likely not due to a change in tonic excitation and/or inhibition of some neuronal structure since: the learning deficit does not recover (tested for up to 3 months in the present studies, tested for up to one and a half years in another study<sup>144</sup>) although general motor ability does rapidly recover; injections of small amounts of Bicuculline into the D-I nuclei also temporarily abolish the learned eyeblink response without causing a marked change in multiple unit activity (Mamounas, Madden, Barchas and Thompson, unpublished observations); the stimulating and recording data (see Chapter 4) suggest a more active role of the cerebellum in the production of the learned eyeblink response.



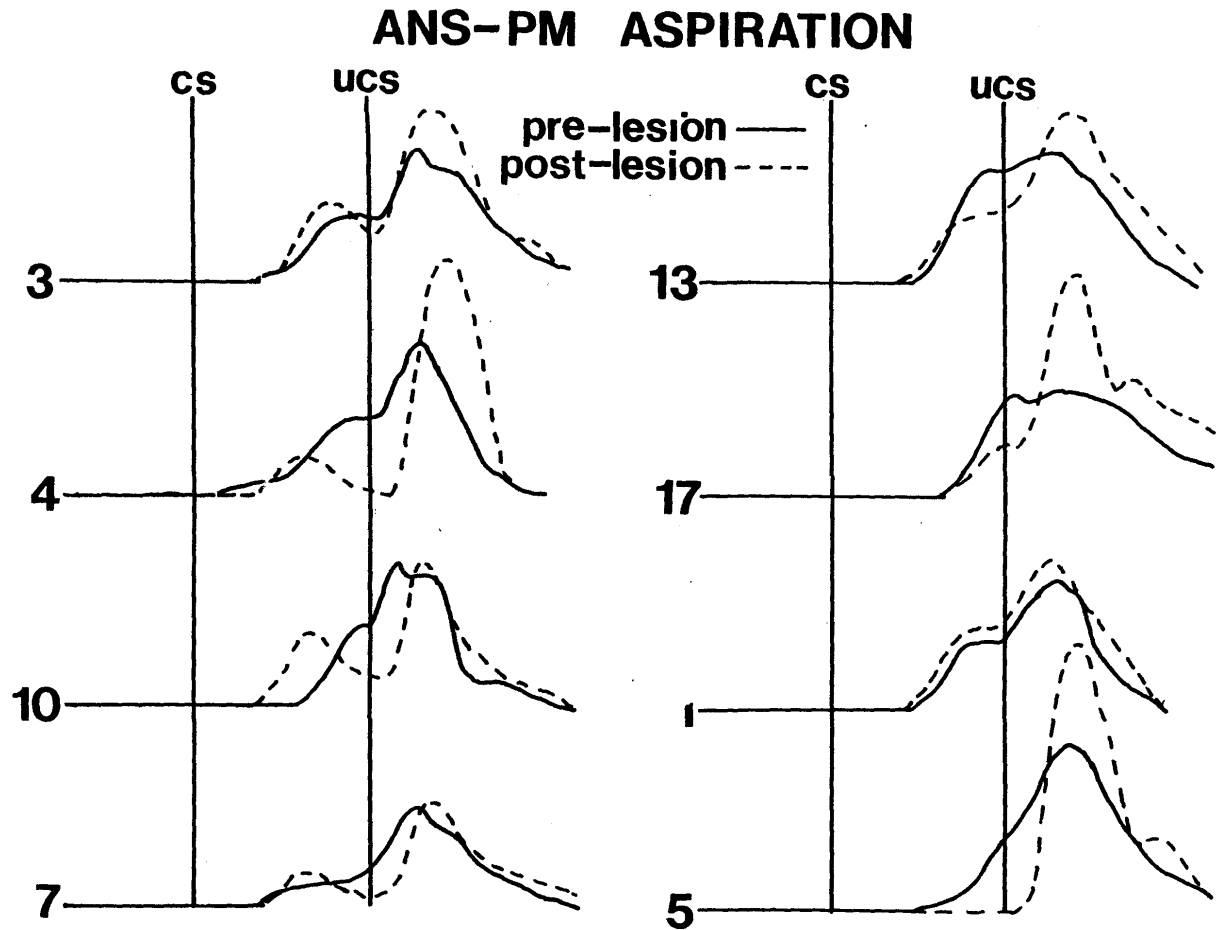

Figure 13 Nictitating membrane (NM) responses of all eight animals with lesions of the ansiform-paramedian cortex. The number beside each tracing is the animal identification number. The solid line represents pre-lesion conditioned responses, while the dashed line represents post-lesion conditioned responses. Note that animal number 11 had only a small amount of ansiform cortex removed, animal number 4 had a lesion restricted largely to the ansiform cortex, and animals 5 and 13 had lesions of the ansiform, paramedian and parafloccular regions of the cerebellar cortex.

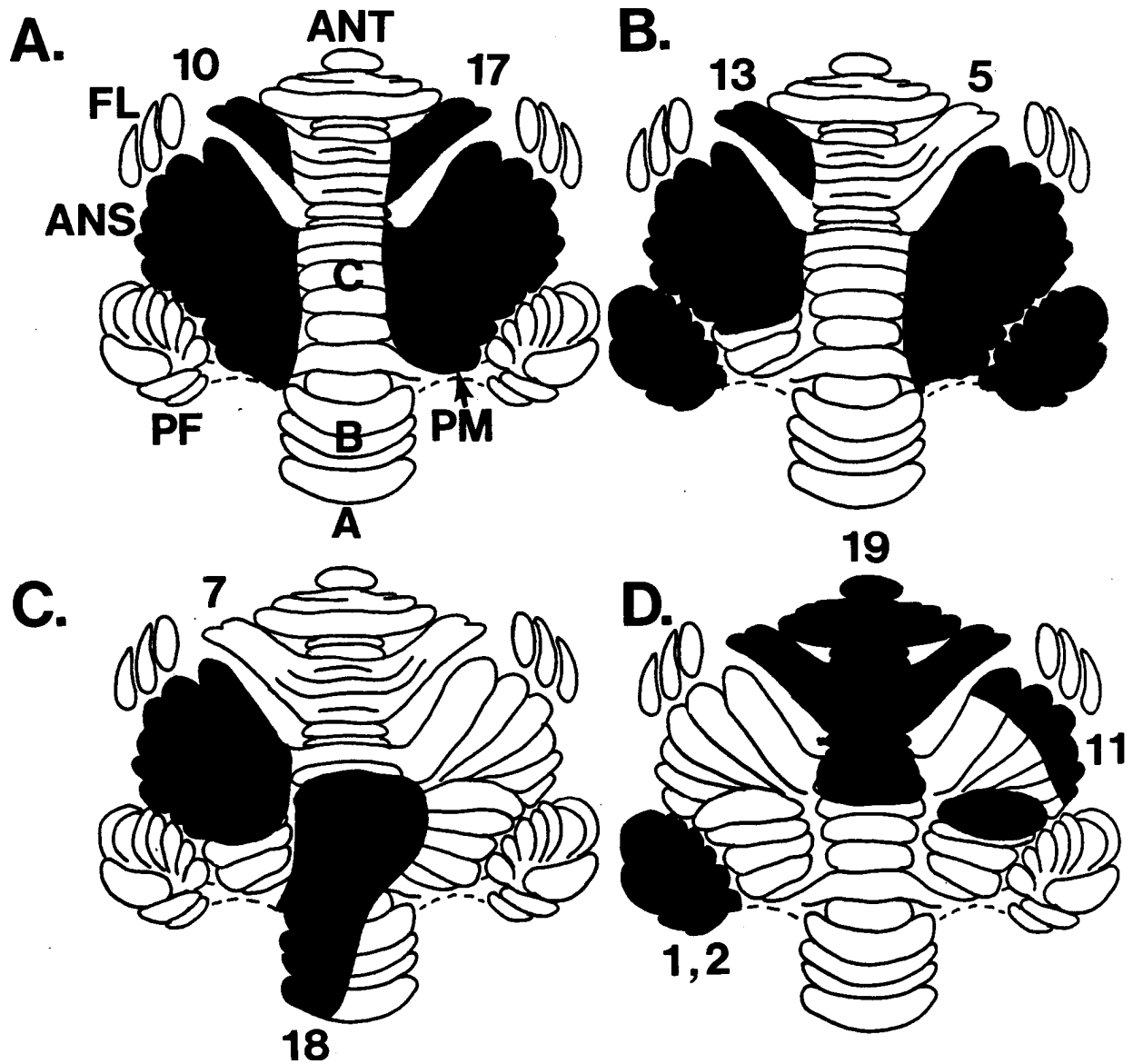

Figure 14 Extent of cortical aspiration in 10 of the animals which were lesioned after training. The number beside each lesion is the animal identification number. Abbreviations are as follows; A - lobule A (nodulus), ANS - ansiform lobule, ANT - anterior lobe, B - lobule B (uvula), C - Lobule C (Pyramis and lobulus medius medianus), FL - flocculus. Representative drawings were adapted from Brodal27.

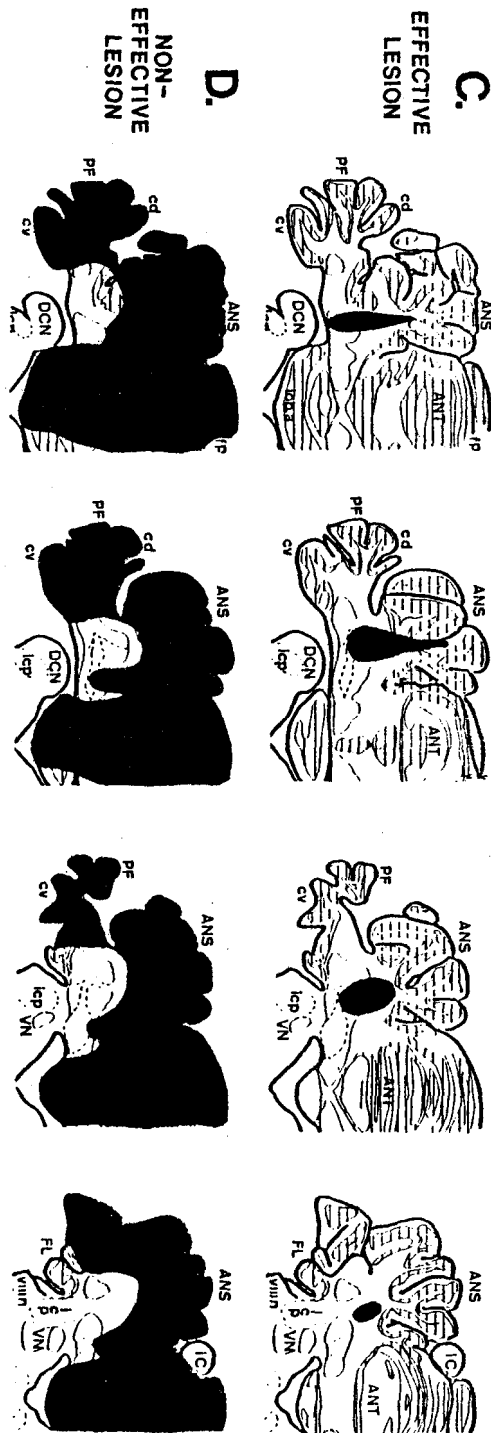

Figure 15 Composite of lesions of the cerebellar cortex which were ineffective in abolishing the learned eyeblink response and a representative effective stereotaxic lesion of the medial dentate and lateral interpositus nuclei which did abolish the learned eyeblink response without effecting reflexive eyeblink responses. Note that the ineffective lesions encompass the effective region. The lateral portions of the dentate nucleus and the fastigial nuclei (bilaterally) are also included in the ineffective zone of the cerebellum. Abbreviations are as follows: ANS - ansiform lobule, ANT - anterior lobe, DCN - dorsal cochlear nucleus, FL - flocculus, IC - inferior colliculus, PF - paraflocculus, PM - paramedian lobule, VN - vestibular nuclei, cd - dorsal crus, cv - ventral crus, fp - primary fissure, icp - inferior cerebellar peduncle, viii n - eighth nerve.

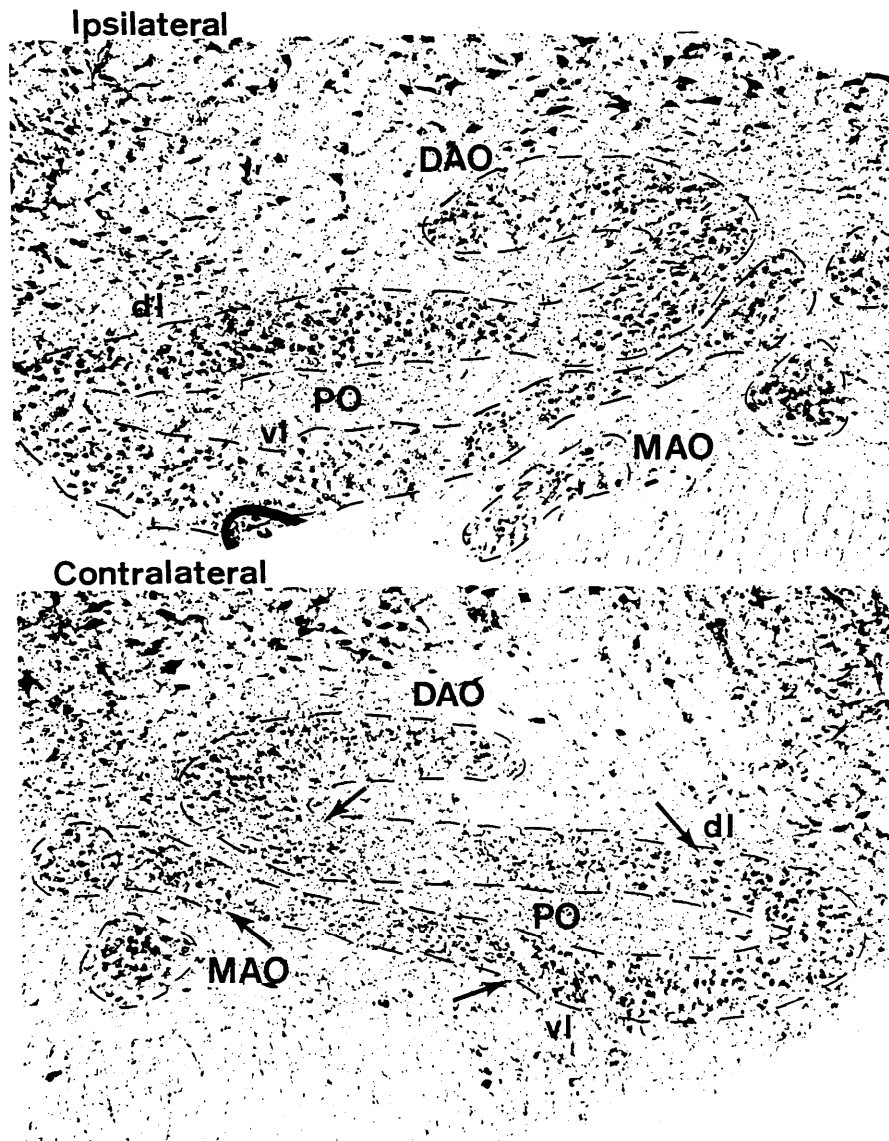

Figure 16 Photomicrographs of the contralateral and ipsilateral inferior olive in animal number 3 illustrating that after removal of portions of the cerebellar cortex a loss of cell bodies within predictable portions of the contralateral inferior olive may occur. In this animal, removal of the ansiform and paramedian lobules caused marked cell loss in the medial portions of the dorsal and ventral lamina of the contralateral principal olive (the region between the arrows). Abbreviations are: DAO - dorsal accessory olive, MAO - medial accessory olive, PO - principal olive, dl - dorsal lamina of the PO, vl - ventral lamina of the PO.

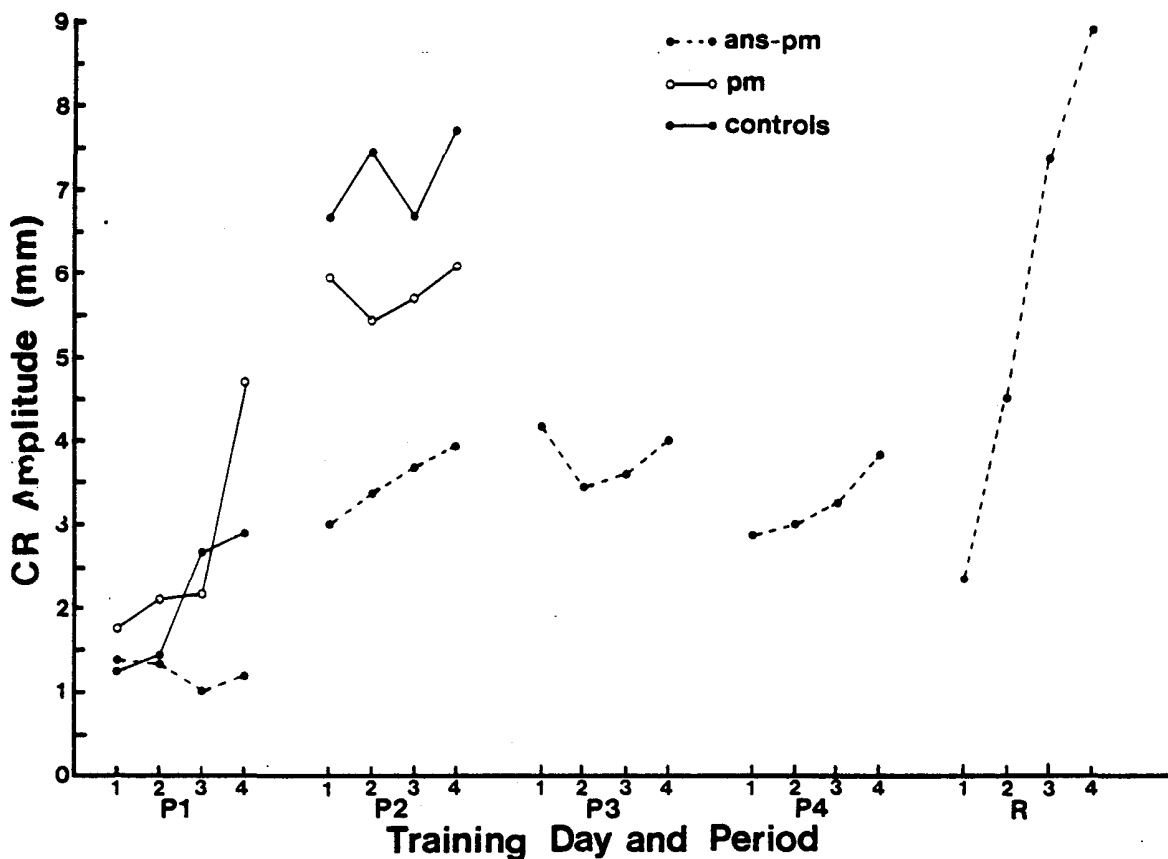

Figure 17 Amplitude of the conditioned NM response over the four days of behavioral training to the ipsilateral NM-eyelid, and the one day of training to the contralateral NM-eyelid. The solid dots and lines represent the non-lesioned control group (n=5), the open dots represent animals with removal of the paramedian lobule (n=2), and the solid dots with dashed lines represents animals (n=7) with removal of the ansiform lobule along with varying amounts of the paramedian lobule. As a group, the ans-pm animals are found to learn at a numerically slower rate than the other two groups, although this result is not statistically significant. This slower group learning rate is due to the fact that three of the seven animals failed to learn the response as well as the other four (see Figures 18 and 19). All ans-pm animals learned the response when training was switched to the contralateral (right - R) NM-eyelid, showing that these animals did not have any generalized learning impairments.

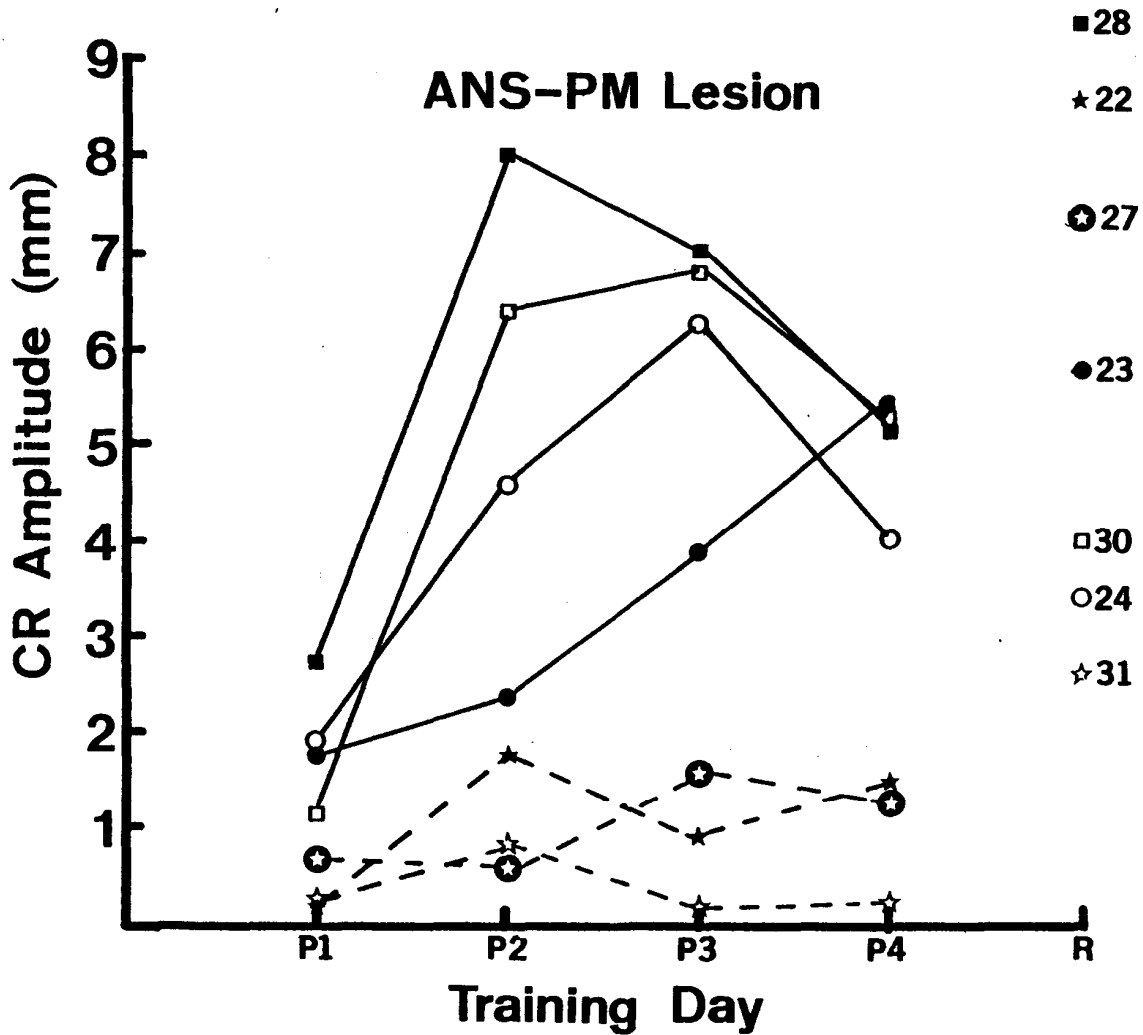

Figure 18 Amplitude of the conditioned NM response for the seven animals with removal of the ansiform - paramedian lobules before training. Four animals are found to acquire the response well with the left NM-eyelid. Three other animals (denoted by stars and dashed lines) did not fully acquire the response. All animals learned the response on the right side. See Figure 19 for the actual NM responses. The number to the right of the symbols is the animal's identification number.

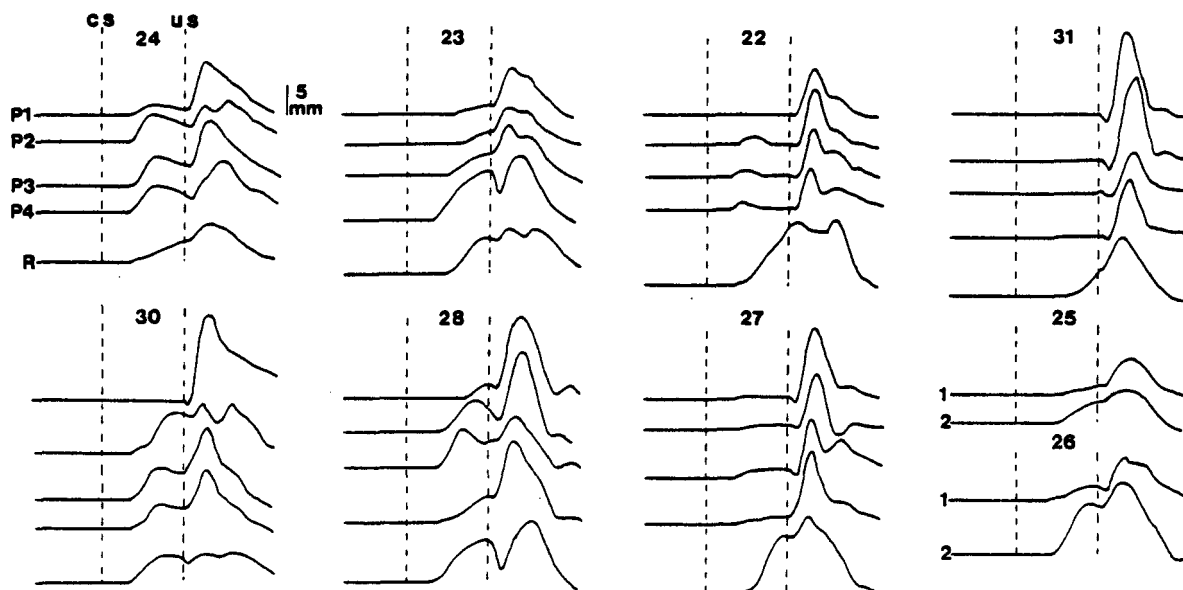

Figure 19 Averaged nictitating membrane responses of all nine animals with lesions of the cerebellar cortex before learning. Each trace is the averaged NM response over all paired trials for that day of training. Each animal received four days of training on the ipsilateral NM-eyelid (labeled 1-4) and then was shifted to the contralateral (right) NM-eyelid. Animals 25 and 26 received only two days of training, both on the ipsilateral side. The number above each trace represents the animal's identification number. The first vertical line denotes the onset of the CS (white noise) while the second vertical line denotes the onset of the UCS (corneal airpuff). The calibration bar to the right of animal number 24 represents an extension of the NM across the eyeball by 5 mm.

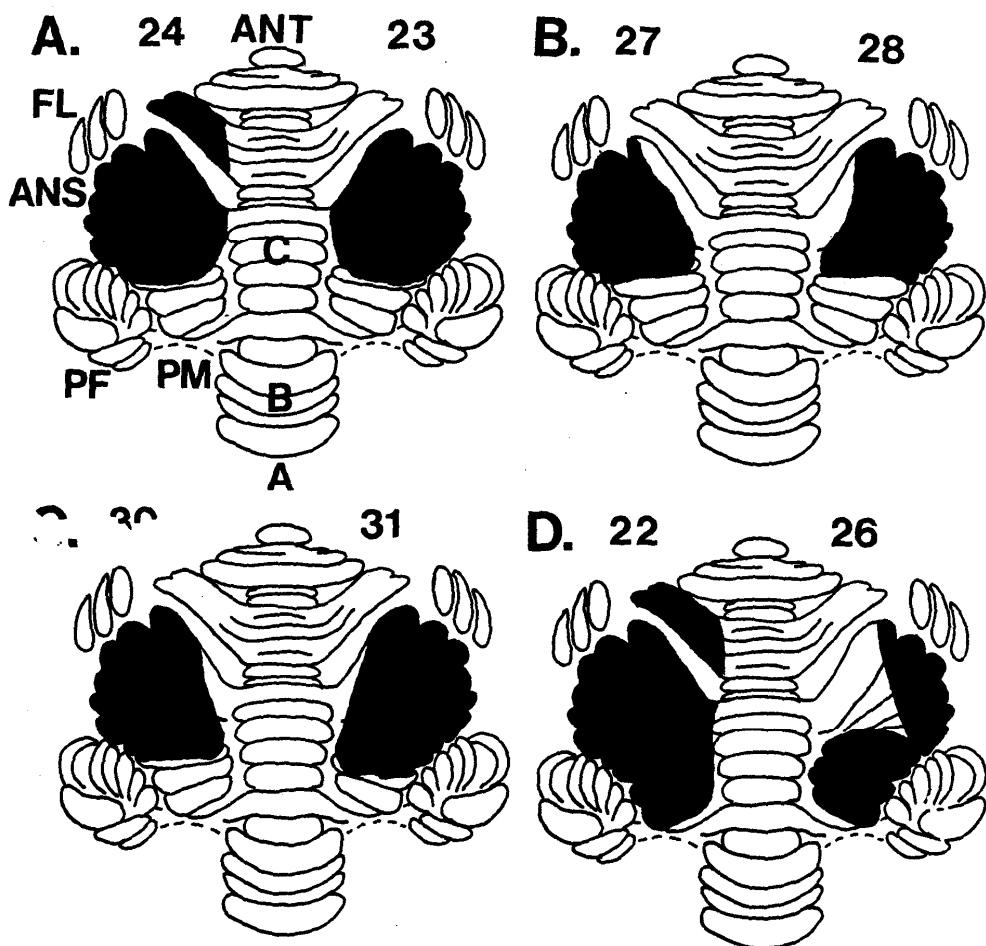

Figure 20 Extent of cortical lesion in eight of the nine animals with cerebellar cortical lesion before learning. In set A, animals 24 and 23 both learned the response at a normal rate. In set B, animal number 28 learned the eyeblink response, while animal 27 failed, even though the region of cerebellar cortex removal was essentially identical. In set C, animal 30 learned while animal 31 did not. Again, these lesions are essentially identical. In set D animal 22 failed to learn the response. This lesion incorporated all of the ansiform cortex, most of the paramedian lobule, and the lateral portions of the anterior lobe. However, complete removal of the paramedian lobule in animal 26 did not prevent learning of the ipsilateral eyeblink response. The lesion of animal 25, who also learned the response, was very similar to that of animal 26. All animals learned the eyeblink response on the contralateral side when training was switched to this side, although animal number 31 learned this response more slowly (see Figure 18). Abbreviations are as follows: A - lobule A (nodulus), ANS - ansiform lobule (crus I and crus II), ANT - anterior lobe, B - lobule B (uvula), C - lobule C (Pyramis and lobulus medius medianus), FL - flocculus.



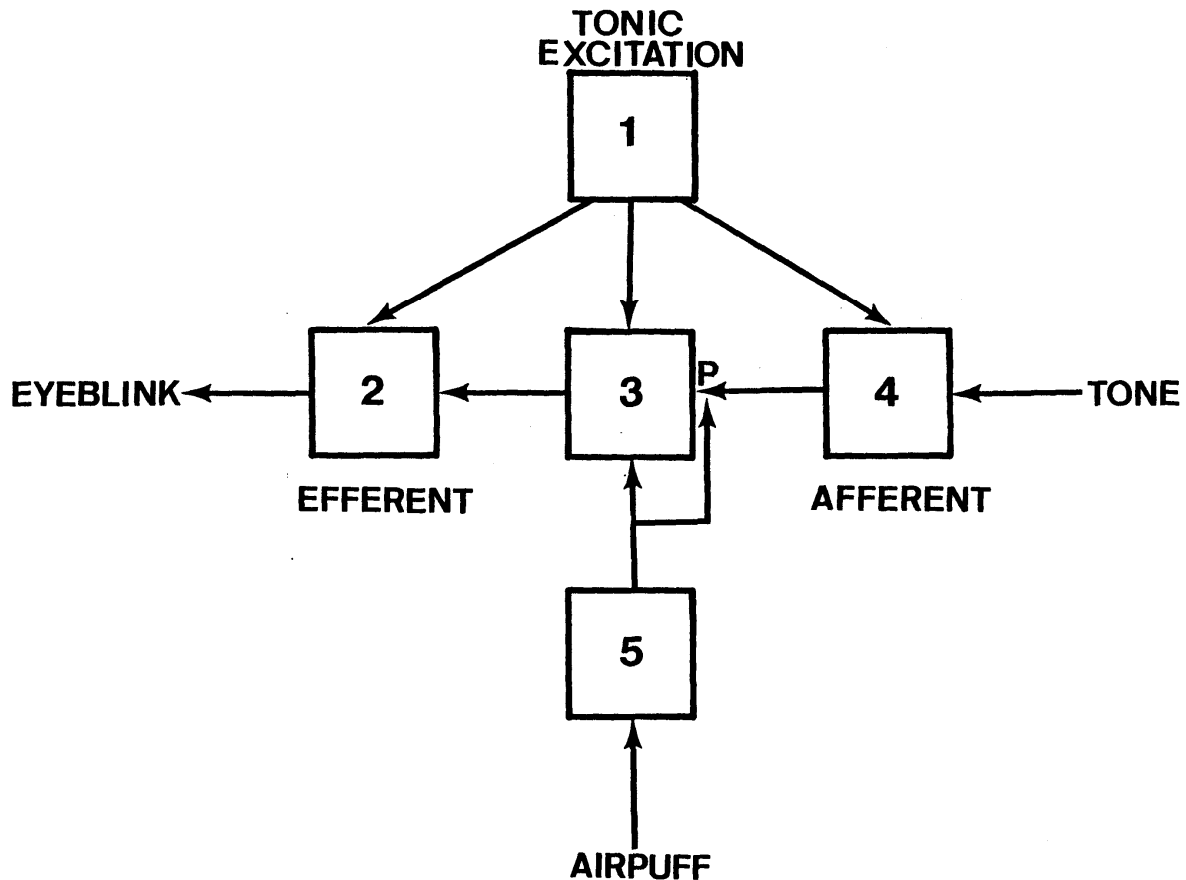

Figure 21 Five possible lesion effects on the learning and retention of the classically conditioned eyeblink response. 1. Lesions cause a change in tonic excitation (or inhibition, or lesion induced malfunction) of some structure involved in the learning and/or performance of the eyeblink response. 2. Lesions block efferent expression of the learned eyeblink response. 3. Lesions remove the *neural* elements which contain the changes in neuronal function encoding the learned response 4. Lesions remove some essential afferent input into the critical site of neuronal change. 5. Lesions block the input of the airpuff sensory input, which would be expected to block learning and/or cause extinction of the learned response. The effects of cerebellar lesions are most consistent with possibilities 2 or 3. Inferior olivary lesions (see Chapter 5) are most consistent with possibilities 1, 2 or 5.

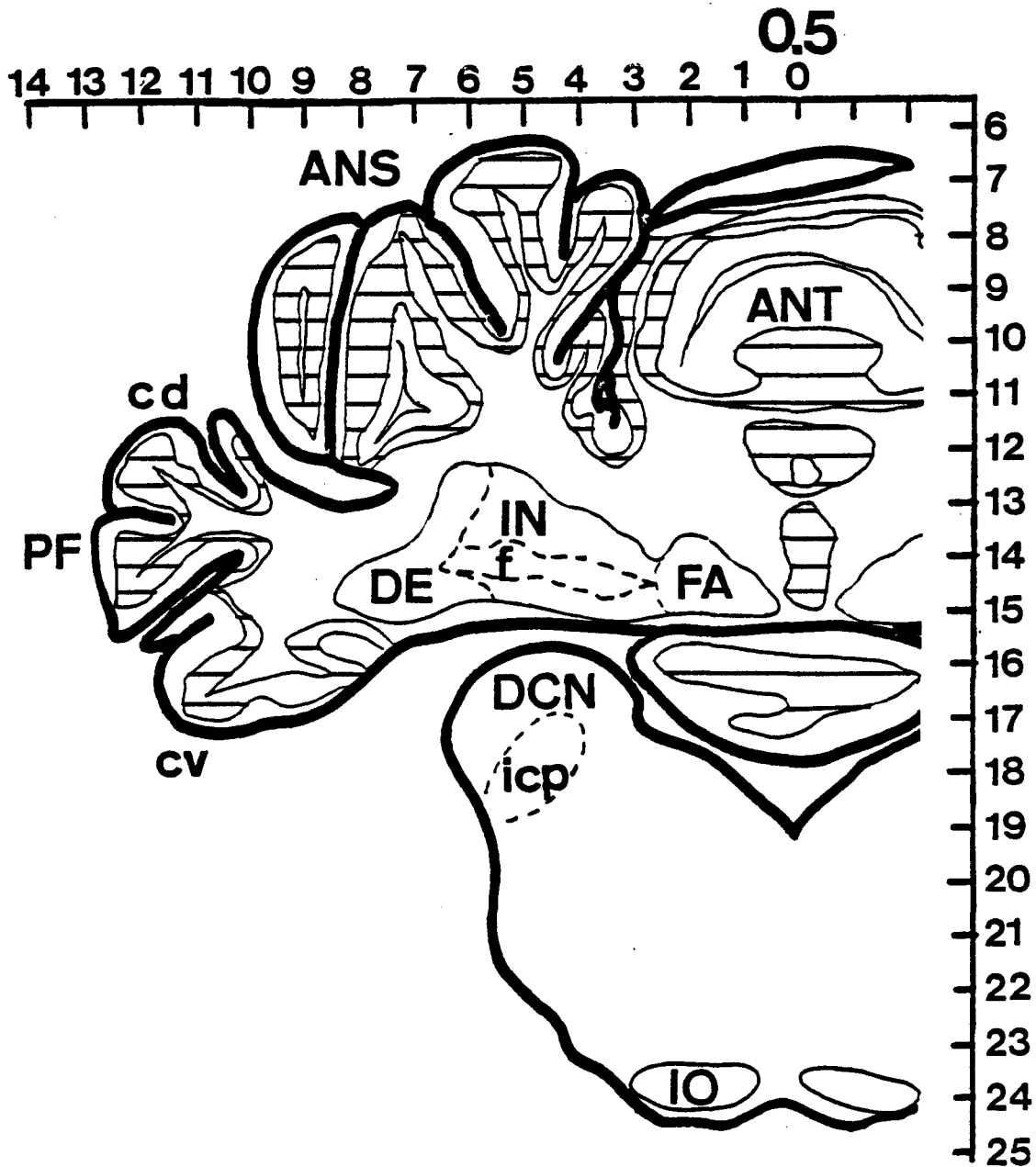

Figure 22 Representative drawing from the stereotaxic atlas of McCormick and Thompson<sup>199</sup> illustrating the position of the D-I nuclei and the ansiform cortex within the cerebellum. The critical region of the deep cerebellar nuclei is the medial dentate and lateral interpositus nuclei, between coordinates 3 to 6.5 mm lateral. Of particular interest may be the more dorsal regions of the D-I nuclei, between 12.5 to 14.0 mm below bone at lambda. Abbreviations are as follows: ANS - ansiform lobule; ANT - anterior lobe; DCN - dorsal cochlear nucleus; DE - dentate nucleus; FA - fastigial nucleus; IN - interpositus nucleus; IO - inferior olive; PF - paraflocculus; cd - dorsal crus (of PF); cv - ventral crus (of PF); icp - inferior cerebellar peduncle. A-P 0.0 corresponds to lambda with anterior being positive.

## CHAPTER 4 - CEREBELLAR AND BRAINSTEM RECORDINGS AND STIMULATION

The data from the previous chapter has revealed that the cerebellum is critical for the production of the learned eyeblink response. However, lesion results alone cannot reveal what this critical involvement is. Therefore, both acute and chronic recording experiments from neurons within the brainstem and the cerebellum were completed during learning and performance of the eyeblink response in the hope that these data may further our understanding of the neuronal mechanisms underlying cerebellar involvement in this simple learned response.

#### Acute Brainstem Recordings

Three hundred and forty one recordings which were deemed acceptable for analysis were obtained from 23 animals. Figure 2 is a reconstruction of the spatial distribution of these recording sites. The middle sections possess a higher proportion of the recording sites than either end due to the overlap of the posterior electrodes of an anteriorly placed manipulator base with the anterior electrodes of a posteriorly placed manipulator base. Adequate recordings were not, of course, obtained from all nuclei. Furthermore, it must be realized that the recording method employed here will certainly miss some

important neuronal activity due to heterogeneous responses within the same recording site. Therefore, in the present report, lack of positive findings with neuronal recordings from a particular structure is in no way definitive evidence that such structure is not involved in the performance and/or learning of the conditioned response. However, the recording sites were of sufficient number and diversity of location to allow for a reasonable approximation of the general distribution of the different types of responses within the brainstem.

The neuronal responses were characterized in the present study in terms of onset latency. The onset of a neuronal response was defined as the first histogram bar which was above the background firing rate and continuous with a larger response which itself was at least twice the background firing rate. If the histogram of a particular recording site contained a neuronal response immediately after the onset of the tone (within 90 milliseconds see Figure L), this recording site was said to have a "T" type response. Likewise, responses with an onset close to the onset of the learned behavioral NM response ( $\pm$  50 milliseconds) and before the onset of the airpuff were classified as an "M" type response. Neuronal responses during the period of the airpuff were labeled "A" type responses (see Figure 1). Each neuronal response was also judged as to its

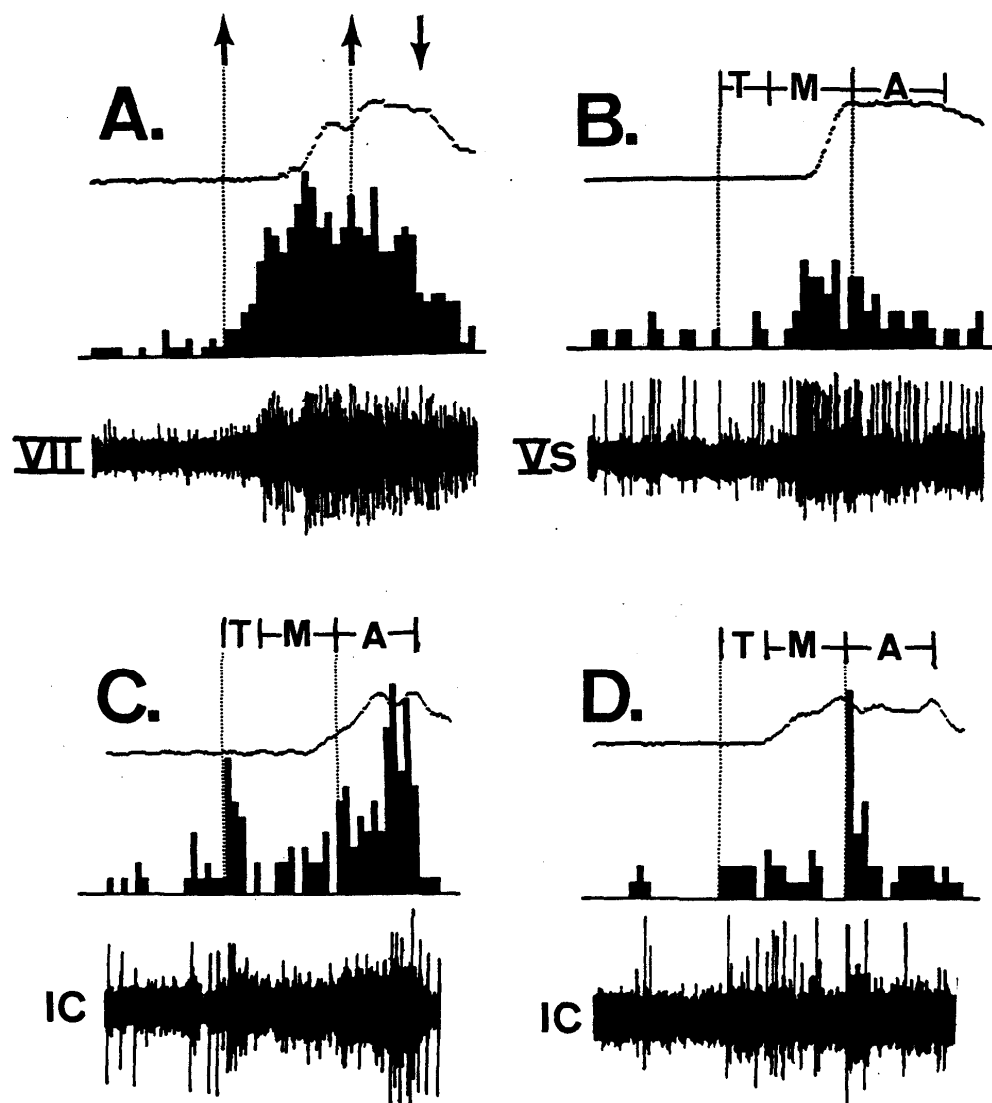

Figure 1 Neuronal recordings from the seventh nucleus, the principle sensory nucleus of the fifth, and the inferior colliculus. Part A illustrates a typical response found in the seventh nucleus. The top trace is movement of the NM with upwards being movement across the eyeball. The second trace is a peri stimulus histogram. Each bar of the histogram is 15 milliseconds in width. The bottom trace is a photograph of the corresponding multiple unit neuronal response on a single trial. The broadening of the baseline is due to the large number of cells co activated and the relatively slow sweep speed of the oscilloscope beam. The first vertical line represents the onset of the tone, while the second vertical line represents the onset of the airpuff. The downward pointing arrow denotes the offset of the tone and airpuff. Part B illustrates a response recorded from the principle sensory nucleus of the fifth. Traces are as in part A of this figure. The letter above the NM trace are the boundaries for the "T", "M", and "A" classifications. Parts C and D are recordings taken from the inferior colliculus. Traces are as in part A.

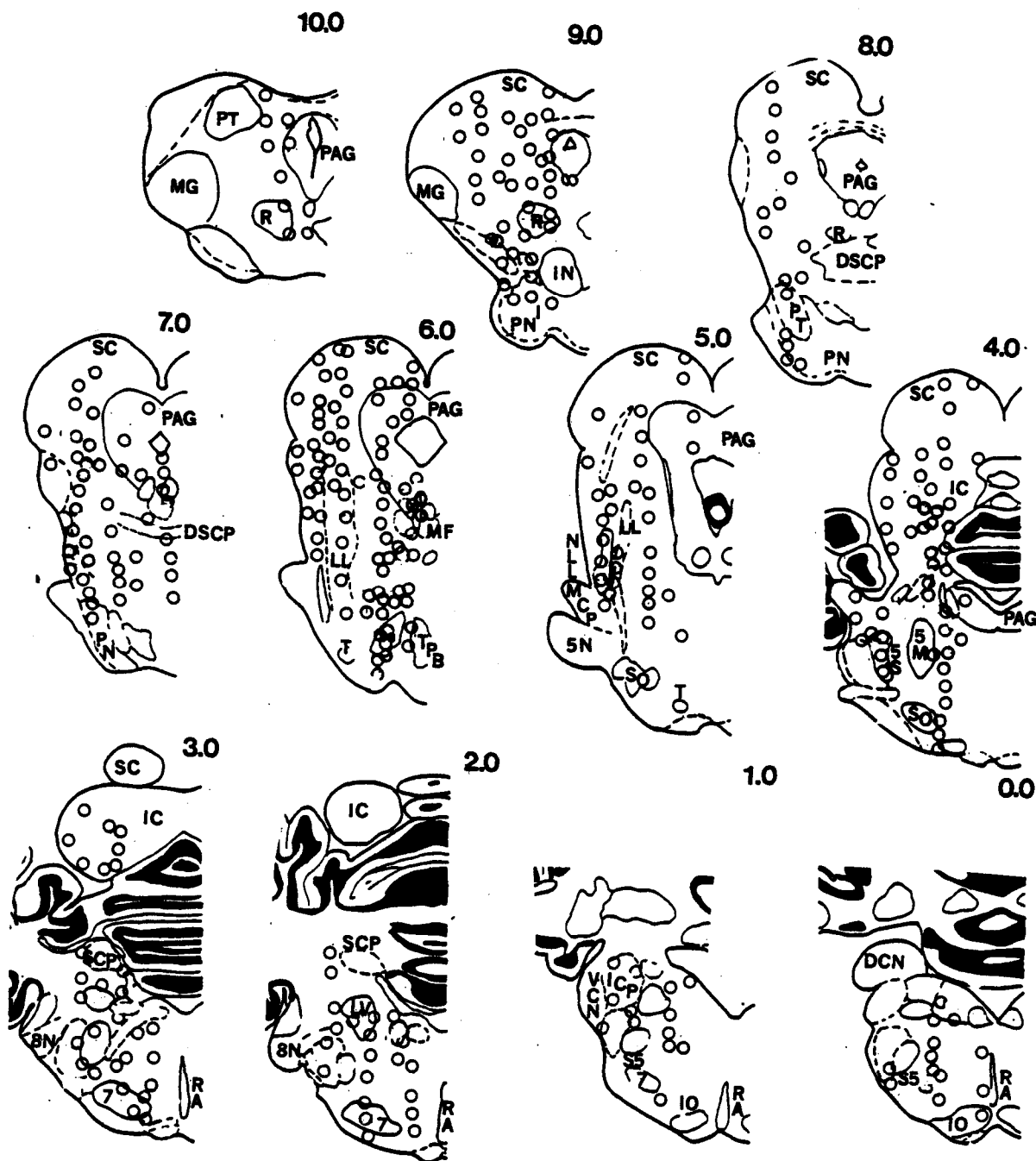

Figure 2 Recording sites from which data were analyzed. Each circle represents an individual recording site of one block of nine trials. Abbreviations are as follows: ,A6 - Accessory sixth (abducens), DCN -dorsal cochlear nucleus, DSCP - decussation of the superior cerebellar peduncle, G7 - genu of the seventh nerve, IC - inferior colliculus, ICP - inferior cerebellar peduncle, IN - interpeduncular nucleus, 10 -inferior olive, LL - lateral lemniscus, LV - lateral vestibular nuclei, M5 - mesencephalic fifth nucleus, MF - medial longitudinal fasciculus, MG - medial geniculate, NLL - nuclei of the lateral lemniscus, PAG -periaqueductal gray, PN - pontine nuclei, PT - pretectal nuclei, R -red nucleus, RA - median raphe, S5 - spinal nucleus of the fifth, SC -superior colliculus, SCP - superior cerebellar peduncle, S0 - superior olive, T - trapezoid nucleus, T5 - tract of the fifth, TD - dorsal tegmental nucleus, TPB - tegmental reticular nucleus (Bechterew), VCN -ventral cochlear nucleus, 5M - motor nucleus of the fifth, 5N - fifth nerve, 5S - principle sensory nucleus of the fifth, 6 - sixth (abducens) nucleus, 7 - seventh (facial) nucleus, 7N - seventh nerve, 8N - eighth nerve.

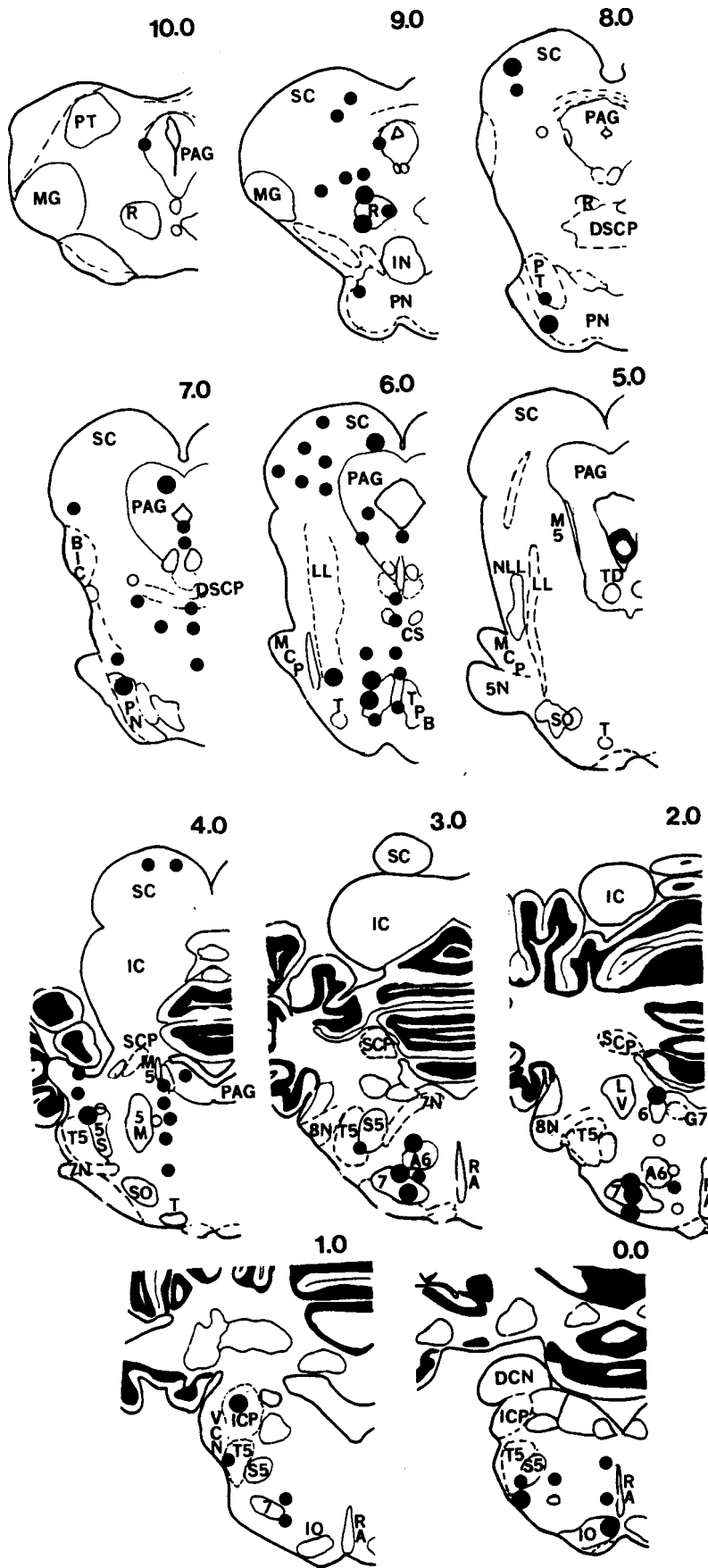

Figure 3 Location of "M" type responses in coronal sections of the brainstem. The larger dots represent the points where large responses were found. Abbreviations are as in Figure 2. The number above each figure denotes the number of millimeters that the section is anterior to lambda. Open circles represent a recording site which not only possessed an "M" type response, but also responded to the tone ("T" type response) as well as the airpuff ("A" type response).

amplitude relative to baseline activity. Responses which were less than twice the baseline activity were arbitrarily labeled as small. Responses which were between two to three times baseline were labeled as medium and responses greater than three times baseline were labeled as large. We report here only the medium and large responses. It must be emphasized that every "M" type response may not be related to the motor control of the behavioral response. For example, a delayed auditory response could conceivably be labeled as an "M" type response. Similarly, "A" type responses may have their basis in a number of systems including the somatosensory, auditory (the airpuff is a white noise stimulus), motor (reflexive response), etc. The "T" responses are purely auditory evoked.

Of the 341 recordings, 111 (33 %) gave only small or no responses to any of the stimuli of any type (T, M, or A), 85 (25%) were found to possess medium or large "M" type responses, 128 (38 %) were found to possess "A" type responses and 90 (26 %) were found to possess "T" type responses. The "T" type responses had an average onset latency of 10.1 milliseconds (standard deviation  $\pm$  11.7 milliseconds) and ranged from 3 to 63 milliseconds, with the great majority of responses having latencies between 6 and 15 milliseconds. The "M" type responses ranged from preceding the NM response by 34 milliseconds for the



facial nucleus to occurring after the NM onset by up to 90 milliseconds for the reticular region medial to the fifth motor nucleus. There were sufficient data to give a reliable estimate of the onset latency of "M" type responses in only certain structures. These latencies are presented below were found within the classical auditory nuclei of the brainstem (e.g. inferior colliculus, superior olive, nuclei of the lateral lemniscus, trapezoid nucleus).

The region of the abducens, accessory abducens, and seventh nuclei contained numerous large and medium "M" type responses (see Figure 4, sections 2 and 3). These responses were found not only within the bounds of the abducens, accessory abducens, and seventh nuclei, but also within the reticular regions surrounding these cell groups. Latency to onset measurements of the neuronal responses found within the seventh nucleus revealed that these responses preceded the movement of the left nictitating membrane (NM) by an average of  $20.7 \pm 22.5$  milliseconds (mean  $\pm$  standard deviation). In contrast, the responses medial to the fifth nucleus were found to follow the NM response by  $20.0 \pm 47.6$  milliseconds.

Some parts of the sensory nuclei of the fifth (principle nucleus, spinal nucleus, and the mesencephalic nucleus) possessed "M" type responses. These responses most probably

represent somatosensory or proprioceptive feedback from the conditioned response (which is often a general contraction of much of the superficial facial musculature). The onset latency of these "M" type responses ( $14.0 \pm 33.5$  milliseconds before the NM) correspond well with such an interpretation, given that the eyelids start to close approximately 20 - 30 milliseconds before the NM. As expected, parts of the fifth sensory nuclei also responded well to the airpuff, presumably responses to the somatosensory component of the stimulus.

To date, the "M" type responses of the cerebellum appear to be relatively localized to at least the ansiform and anterior lobes and discrete parts of the dentate-interpositus nuclei (see below). The present study has revealed that brainstem nuclei which are directly connected with the cerebellum (pontine nuclei, tegmental reticular nucleus (Bechterew), red nucleus, and perhaps the inferior olive) may also respond in correlation with the onset and/or the amplitude-time course of the behavioral conditioned response. The fact that "M" type responses were found in structures contralateral in nature (e.g., pontine nuclei) may be explained by the fact that the conditioned eyeblink response in most animals is to some degree bilateral. The illustrations of "M" type responses found within the pontine nuclei and the red nucleus of Figure 4 reveal that

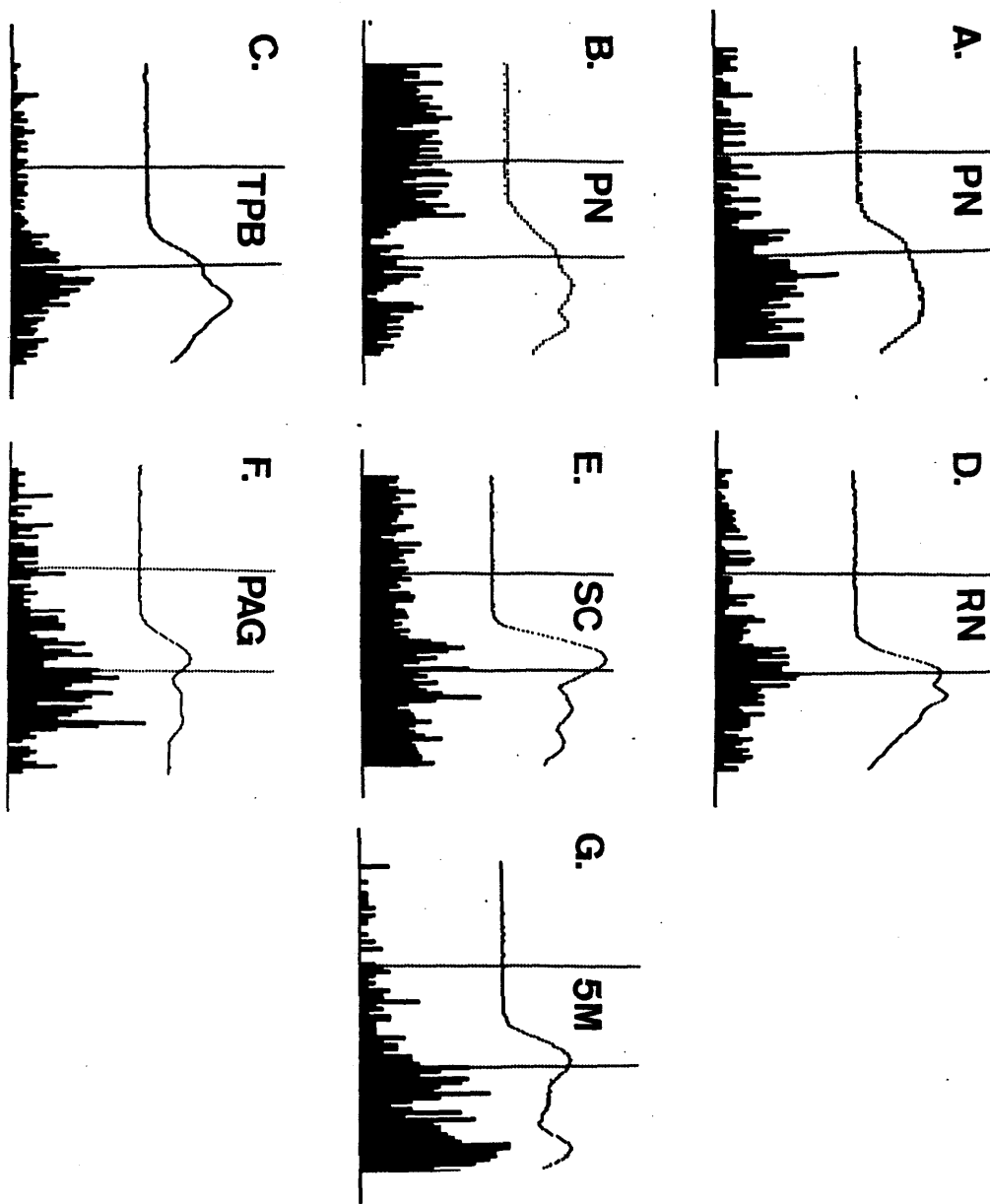

Figure 4 Examples of "M" type neuronal responses recorded from brainstem nuclei. A and B are from the lateral pontine nuclei, C - tegmental reticular nucleus (Bechterew), D - Red nucleus, E - Superior colliculus, F - Periaqueductal gray, and G - just medial to the fifth motor nucleus. The upper trace in each set represents the movement of the NM response with up being closure averaged over eight paired trials. The lower trace is an average peri stimulus histogram of the neuronal response recorded for the same eight trials. The first vertical line represents the onset of the tone, while the second vertical line represents the onset of the airpuff. Each bar of the histograms is 9 milliseconds in duration.

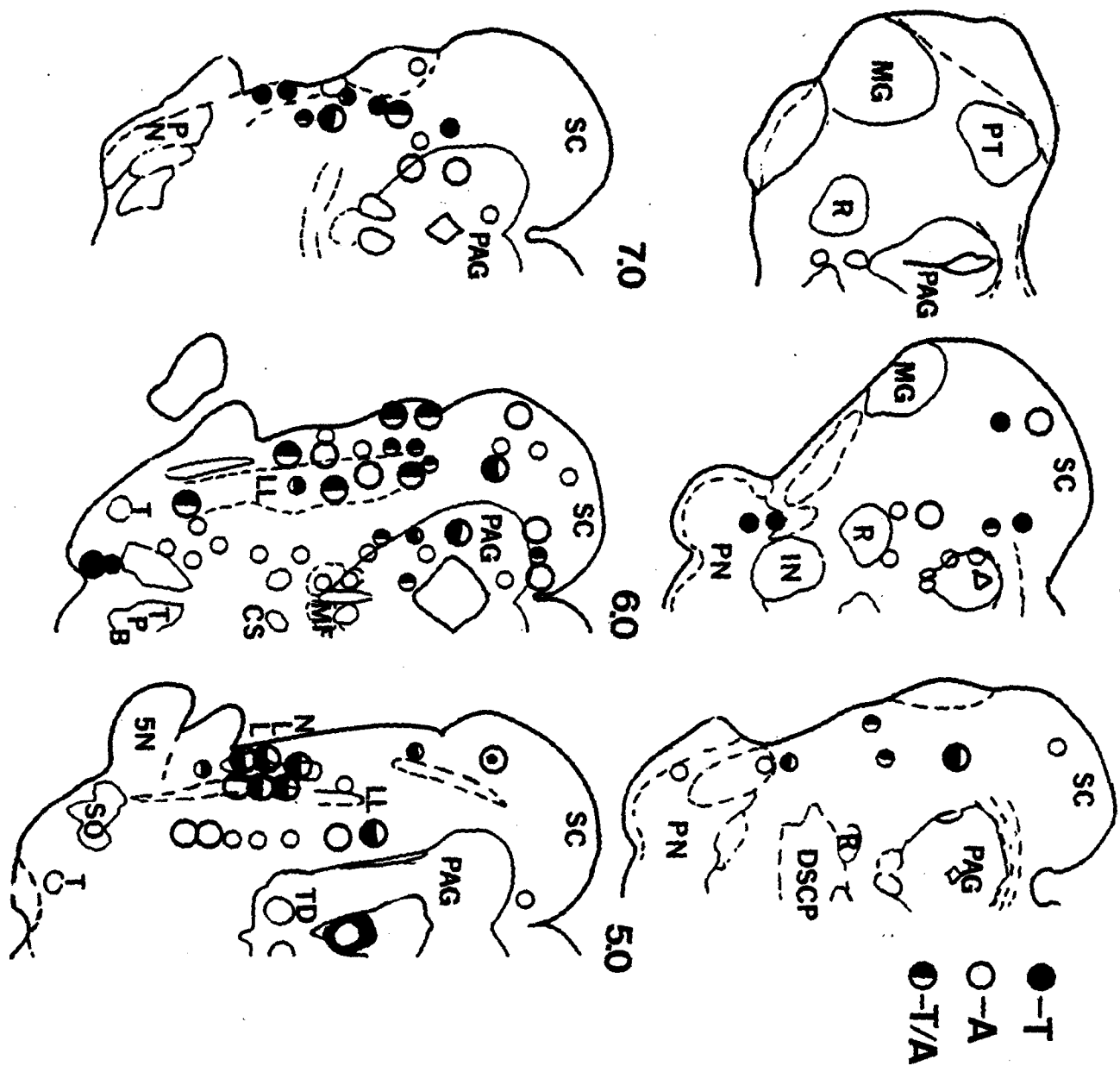

Figure 5 Anterior sites of stimulus evoked (tone, airpuff) responses. A black dot corresponds to a neuronal response to the tone ("T" type response). An open circle corresponds to a response to the airpuff ("A" type response). A dot that is half black and half white represents a neuronal response to both the tone and the airpuff. The size of the dot represents whether the response was deemed medium (smaller dots) or large (larger dots). If a response to the tone was significantly larger than the response to the airpuff, then the dot was set so that the black half was up, and vice versa. The size of the dot represents the judged size of the larger response. Abbreviations are as in Figure 2.



Figure 6 Posterior sites of stimulus evoked responses. See Figure 5 for explanation. Abbreviations are as in Figure 2.

these responses have an onset which is after the onset of the behavioral NM response. However, the amount of data in the present study is of insufficient size to make an accurate estimate as to the true average latency of "M" type responses within these two nuclei. Furthermore, given the fact that the conditioned responses of individual rabbits in the present paradigm have differing onset latencies, comparison of the onset latency of the neurons within the pontine nuclei or red nucleus

Neuronal responses were found within the superior colliculus which correspond to all three classifications, although responses to the tone were less numerous than responses to the airpuff or responses which correlated with the onset of the behavior. The "M" type neuronal responses of the superior colliculus tended to possess a sharp onset and offset and were somewhat sustained between. Furthermore, on the average these responses followed the onset of the NM behavior by  $34.4 \pm 40.8$  milliseconds (see Figure 4).

The responses of the PAG varied considerably between recording sites. Of the 23 recordings taken from the PAG, 9 possessed "M" type responses. Of all the "M" type responses, the responses of the PAG were among the smallest and most variable. Only 2 % of the recording sites of the present study possessed responses of all three classifications - "T", "M", and "A" (see

below). However, a number of structures were found to possess all three classifications of responses (not necessarily from the same recording site). The PAG was one such structure. Other structures which possessed all three type responses were the reticular region near the abducens, accessory abducens, and seventh nuclei, the superior colliculus, the pontine nuclei, the cerebellum, and various reticular regions.

Figures 5 and 6 illustrate the distribution of the "T" and "A" type responses. As would be expected, recordings taken from the nuclei of the classical brainstem auditory system (inferior colliculus, superior olive, nucleus of the trapezoid body, nuclei of the lateral lemniscus, cochlear nucleus) possess both "T" and "A" type responses. Responses to the airpuff are expected within nuclei of the auditory system since the escape of the air from the outlet nozzle generates a broad band noisy stimulus. Other regions which possess "T" and "A" type responses were the superior colliculus, periaqueductal gray, pontine nuclei, fifth sensory nucleus, and reticular regions adjacent to the abducens-accessory abducens-facial nuclear complex and the reticular region medial to the fifth motor nucleus. Neuronal responses to the airpuff alone (55/341 - 16 %) were found in the superior colliculus, fifth sensory nucleus, lateral lemniscus, periaqueductal gray, and reticular regions adjacent to the

sixth-accessory sixth-seventh nuclear complex, and the reticular regions adjacent to the lateral lemniscus, tegmental reticular nucleus (Bechterew), and the red nucleus.

Of the 341 recordings, only 7 (2 %) were found to possess all three classifications of responses ("M", "T", and "A"). The sites responding in this manner are represented in Figures 3. Three of these sites were found in the reticular region surrounding the sixth-accessory sixth-seventh complex (see level 2.0, Figure 3). Responses possessing all three classifications were also found within some parts of the cerebellum (see below). Since the present recordings were of unit clusters, it is not known whether or not the same or different neurons were generating each of the response types.



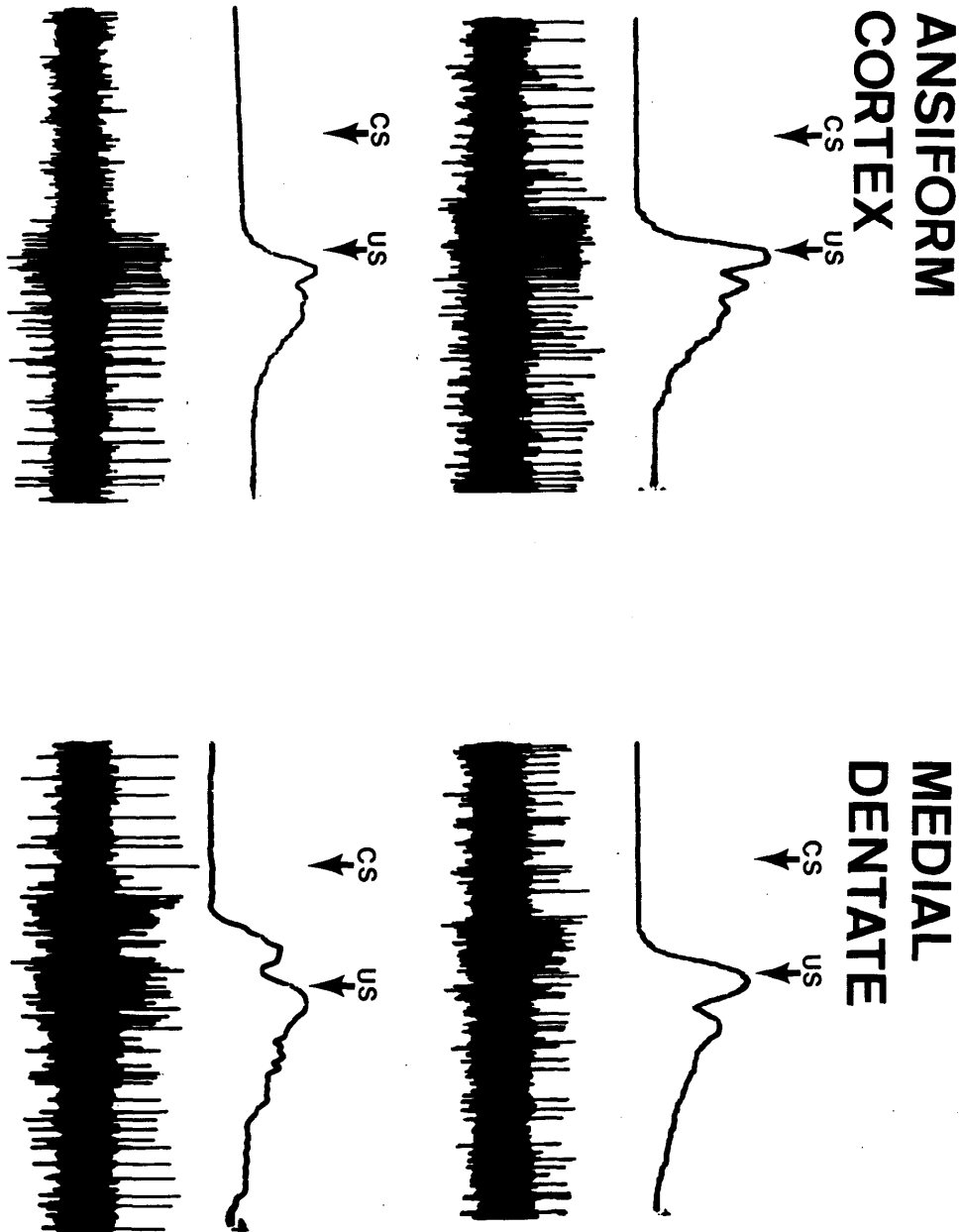

Figure 7 Examples of multiple unit activity ("unit clusters") from the ansiform cortex and the medial dentate-lateral interpositus nuclear region during performance of the learned nictitating membrane (NM) extension and eyelid closure response. The top trace of each record represents the movements of the NM with up being extension across the eyeball. The lower traces are the unit activity recorded from one training trial. Arrows indicate the onset of the conditioned stimulus (tone) and the unconditioned stimulus (corneal airpuff). Each trace is one second in length.

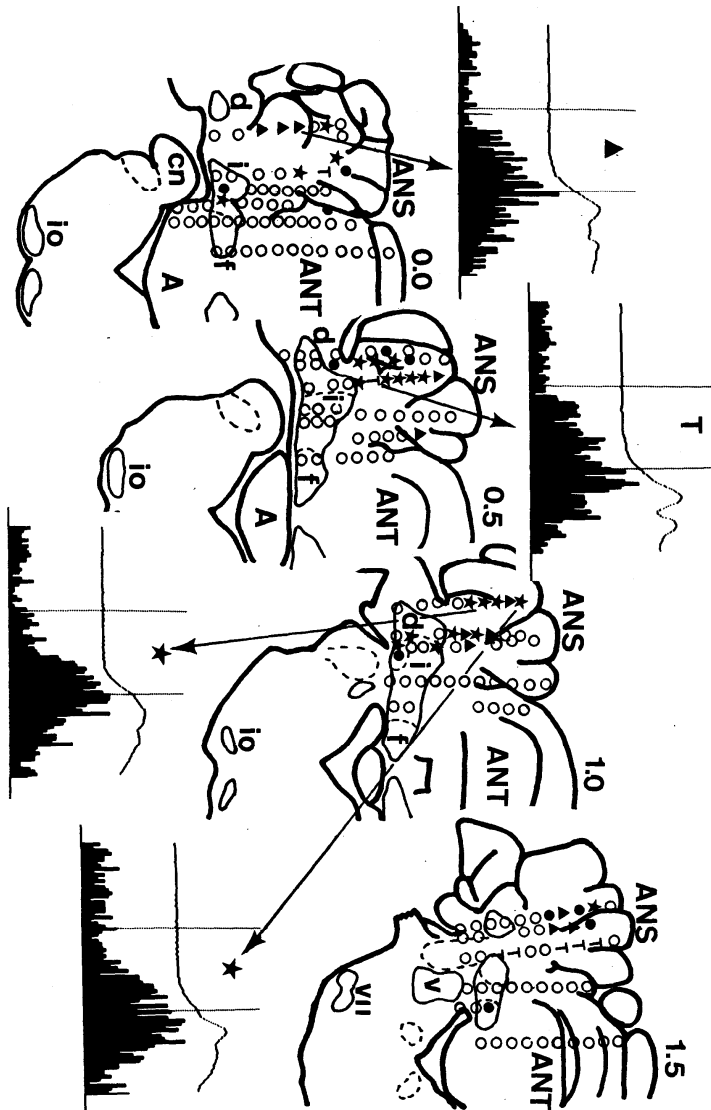

Figure 8 Neuron responses in the anterior sections of the cerebellar cortex during performance of the conditioned eyeblink response. A star ( ) indicates a recording site in which the onset of the unit activity significantly covaried ( $r > .62$ ) with the onset of the behavioral NM response. Triangles ( ) indicate neuronal responses which did not significantly correlate with the onset of the conditioned response. A "T" indicates a recording site in which the onset of the neuronal response did not covary with the NM response and was less than 50 milliseconds after the onset of the tone. Within the peri stimulus histograms, the upper trace represents the movements of the NM with up being extension across the eye. The first vertical line represents the onset of the tone while the second vertical line represents the onset of the corneal airpuff. Each histogram bar is 9 milliseconds in duration and each trace is a total of 750 milliseconds in duration. Abbreviations are as follows: ANS - ansiform lobule (Crus I and Crus II); ANT -anterior lobe; FL - flocculus; DCN - dorsal cochlear nucleus; IO -inferior olive, Lob. a - lobulus A (nodulus), Lob. b - Lobulus B (Uvula); Lob. c - Lobulus C (pyramis and medius medianus); PF - paraflocculus; VN - vestibular nuclei; cd - dorsal crus; cv - ventral crus; g vii -genu of the tract of the seventh nerve; icp - inferior cerebellar peduncle, vii - seventh (facial) nucleus; vii n - nerve of the seventh nucleus.

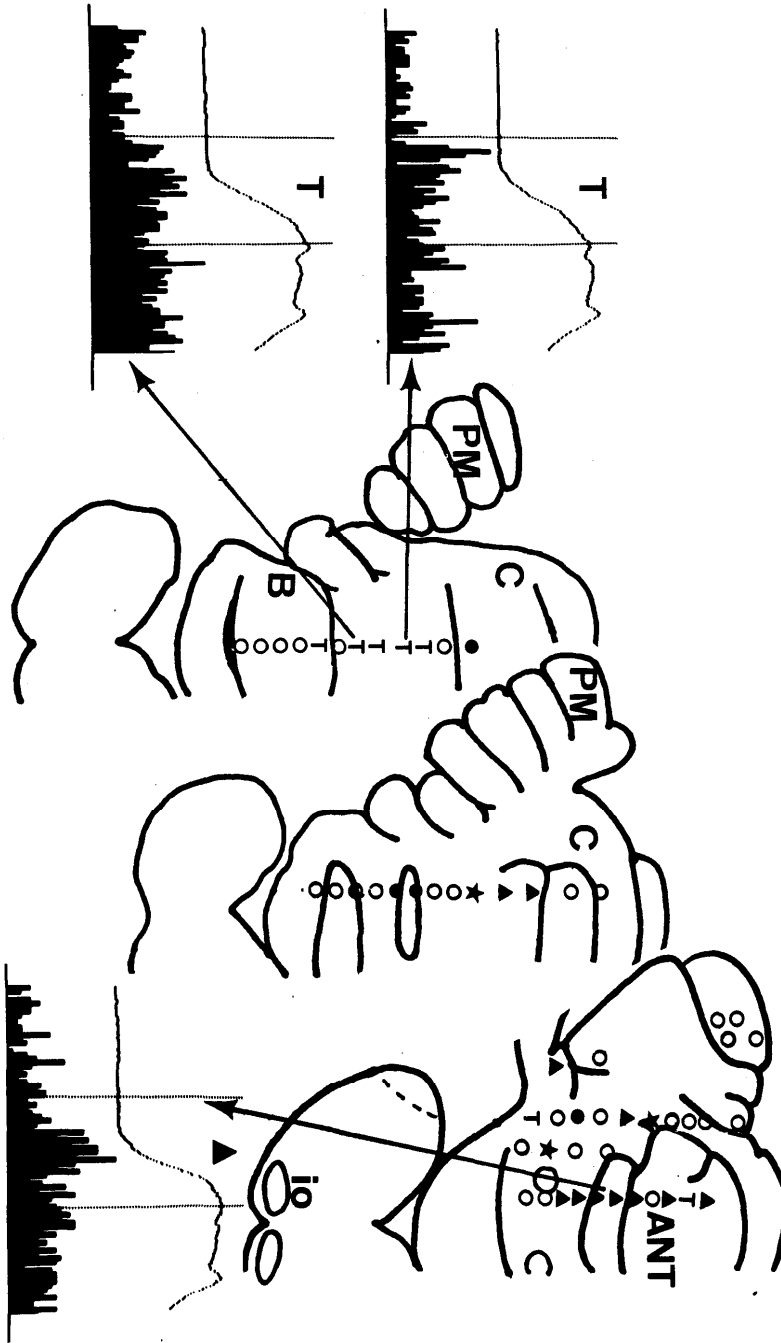

Figure 9 Neuronal responses in the posterior sections of the cerebellar cortex during performance of the learned eyeblink response. See Figure 8 for explanation and abbreviations.

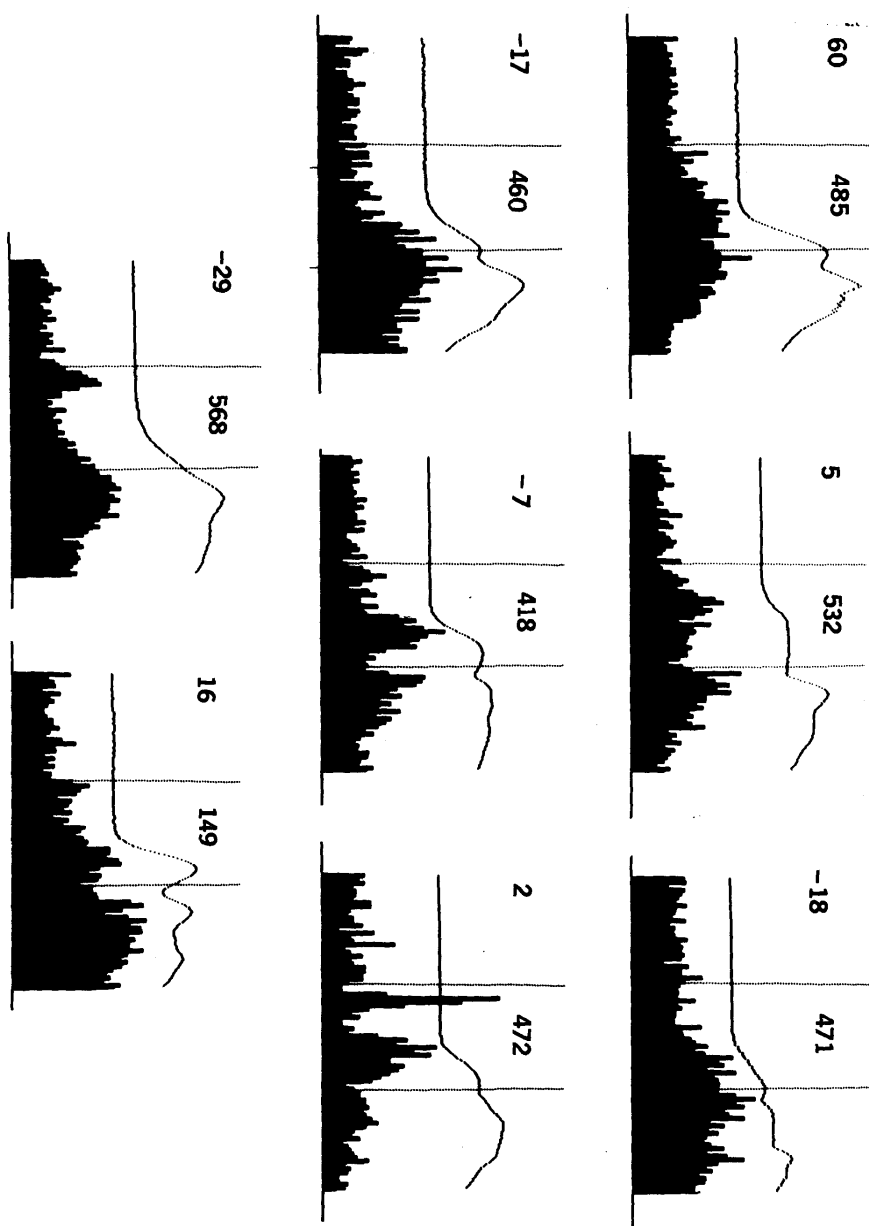

Figure 10 Examples of neuronal responses within the dentate-interpositus nuclei during performance of the learned eyeblink response. Each histogram is 750 milliseconds in duration and is an average of all paired trials on the day of overtraining, with each histogram bar being 9 milliseconds in duration. The first vertical line represents the tone onset while the second vertical line represents the onset of the corneal airpuff. The number above each histogram corresponds to the animals identification number. The average difference in onset latency between the neuronal responses and the NM behavioral response is indicated in the upper left corner of each histogram, with positive latencies indicating responses which occurred before the NM response.

### Cerebellar Acute Recordings

Three hundred and twenty-three neuronal recordings which were deemed acceptable for analysis were obtained from throughout the lateral cerebellar cortex and deep nuclei (see Figures 8 and 9) with 91 of the recordings coming from the ansiform lobule. Of these recordings 90/323 (28 %) were found to respond in the CS period. These responses were located within the ansiform lobule, the anterior lobe, and within portions of the midline (vermal) cortex. In an effort to differentiate between responses in the CS period which were related to the production of the eyeblink conditioned response (CR), and those neuronal responses which may be related to the occurrence of the tone and/or perhaps other behavioral components of the conditioned response (e.g. increased movements of the vibrissae)<sup>190</sup> latency to onset correlations between the unit activity and the NM onset were calculated for each recording site (see Methods). Twenty-nine (32%) of the responses within the CS period yielded significant correlations ( $r > .62$ ,  $df = 8$ ). The majority (72 %) of these responses were found within the ansiform cortex above the dentate-interpositus (D-I) nuclei (see Figure 8). The significant correlations from this region ranged from .76 to as high as .98 with a mean value of .88. The relatively high value of many of these correlations indicates that these responses were

highly related to the amplitude-time course of the learned eyeblink response (see Figures 7 and 8). The mean onset latencies for these neuronal responses was  $29.3 \pm 16.5$  msec before the onset of the NM response, and ranged from 5 msec to 59 msec before the onset of the NM response. The neuronal responses found within the midline folia did not correlate significantly with the onset of the NM behavior (see Figure 9). The responses of the more posterior folia, in some cases, possessed relatively short latency responses after the onset of the tone ( $< 50$  msec), and did not covary with the onset of the NM response. Such results indicate that these responses were probably more related to the onset of the tone rather than to the onset of the NM behavioral response, and therefore were labeled "T" type responses (see Figure 9). Similar responses were also found scattered throughout the ansiform cortex (see Figure 8). Interestingly, a number of chronic sites within the dentate-interpositus (D-I) nuclei also possessed similar characteristics (see below).

The neuronal responses found within the posterior sections of the anterior lobe (level -1.0, Figure 9) did not correlate with the NM behavior nor did they occur with a short enough latency after the onset of the tone to be labeled "T" responses. However, it was noticed that these neurons fired in

phase with the animal's respiration. Since it is known that some animals develop a conditioned increase in movements on the nasal musculature involved in respiration the neuronal responses of this region may represent proprioceptive or somatosensory feedback from the muscles and skin surfaces involved in such movements (e.g. nasal region and vibrissae).

### Chronic Recordings

Fifty-four chronic recordings were obtained from the deep cerebellar nuclei in 32 animals over the course of learning. Of the 54 chronic recordings, 22 (41%) were found to exhibit "T" type responses (see above) at some point during behavioral training. The majority (16/22) of these responses were relatively small and seen clearly only on average histograms of a number of trials. The average onset latency of these responses was 12.0 msec (+ 3.7 msec), which agrees with earlier reports of response latencies of neurons within the dentate-interpositus nuclei to intense auditory stimulation in the monkey<sup>214,215</sup>. The large majority of these "T" responses were present throughout behavioral conditioning. A small number of the responses either significantly increased in size (4/22) or decreased in size (4/22) during behavioral conditioning.

Responses to the onset of the airpuff were found within 42

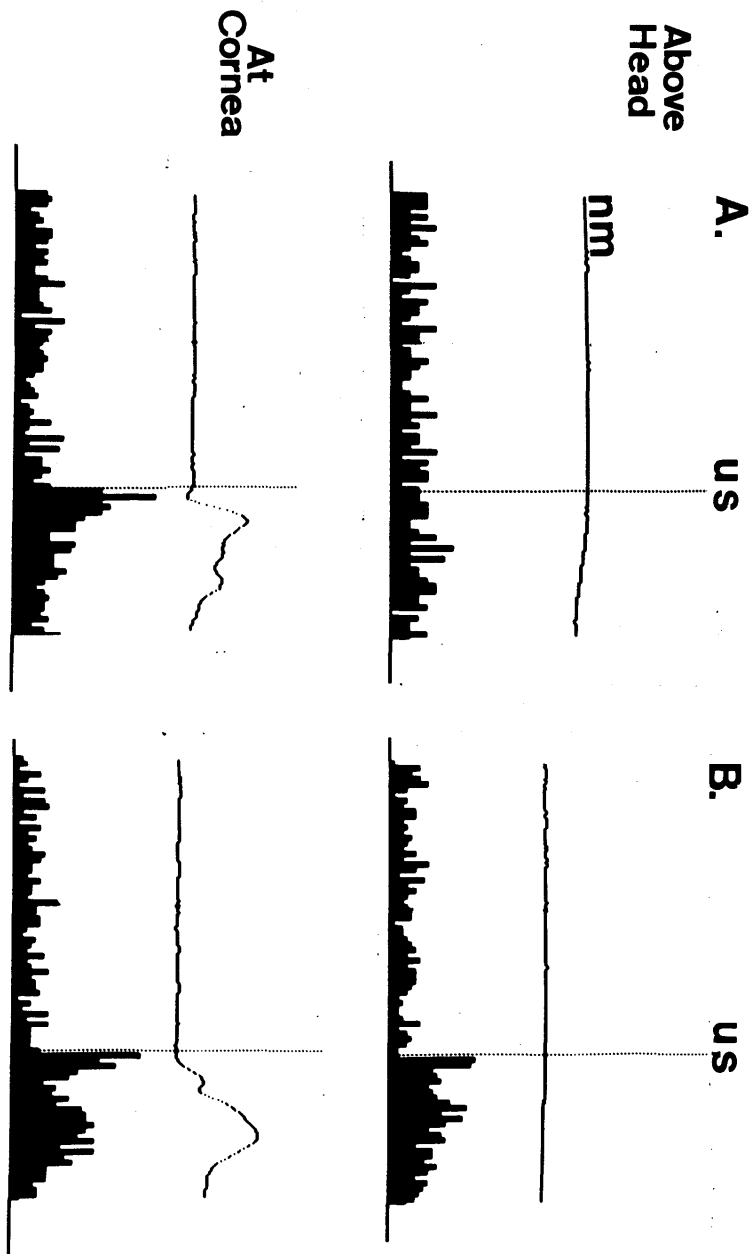

Figure 11 Effect of misdirecting the airpuff away from the cornea on the responses of the dentate-interpositus nuclei to this stimulus. Part A illustrates an example in which the response to the airpuff was dependent upon direction of the airpuff at the animal's cornea, therefore implying that this response is related to somatosensory inputs and/or performance of the unconditioned eyeblink response. Part B illustrates a case in the misdirection of the airpuff did not significantly alter the neuronal response, thereby implying that these neurons are responding to the auditory components of the airpuff. The airpuff is a broad band noisy stimulus generated by escape of the air from the outlet nozzle. Note the sharp onset and short latencies of both responses. This is typical of the neuronal responses to both the tone and the airpuff.



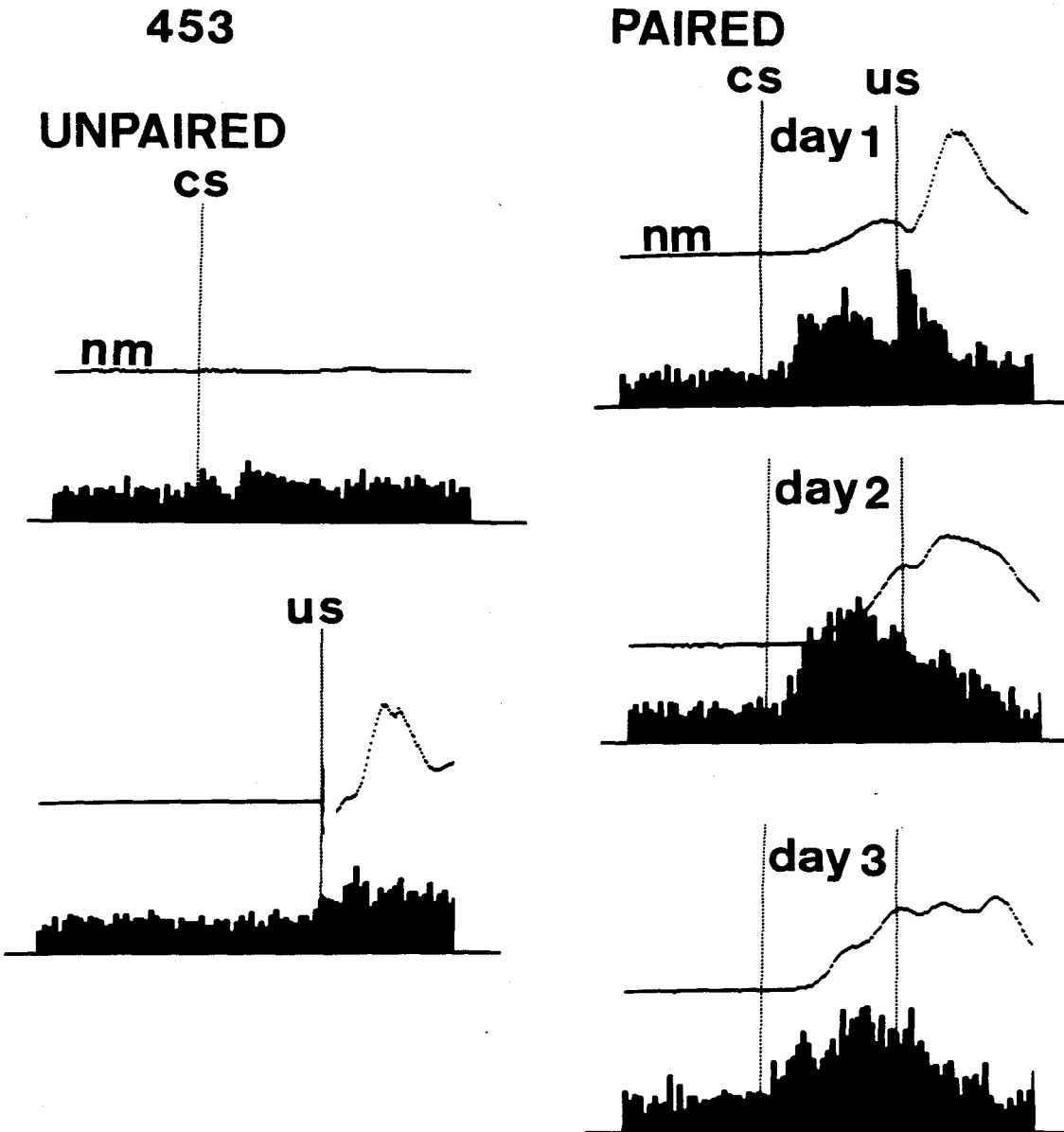

Figure 12 Example of the most impressive change in neuronal unit activity within the dentate-interpositus nuclei during unpaired and paired presentations of the training stimuli. The animal was first given pseudo randomly unpaired presentations of the tone and corneal airpuff, in which the neurons responded very little to either stimulus. However, when the stimuli were paired together in time, the cells began responding within the CS period as the animal learned the eyeblink response. The onset of this unit activity preceded the behavioral NM response within a trial by 36 - 58 milliseconds. Stimulation through this recording site yielded ipsilateral eyelid closure and NM extension. Each histogram bar is 9 milliseconds in duration. The upper trace of each histogram represents the movements of the NM with up being extension across the eyeball. Histology revealed that this recording site was on the boundary between the dentate and interpositus nuclei, in a site similar to that of Figure 13.

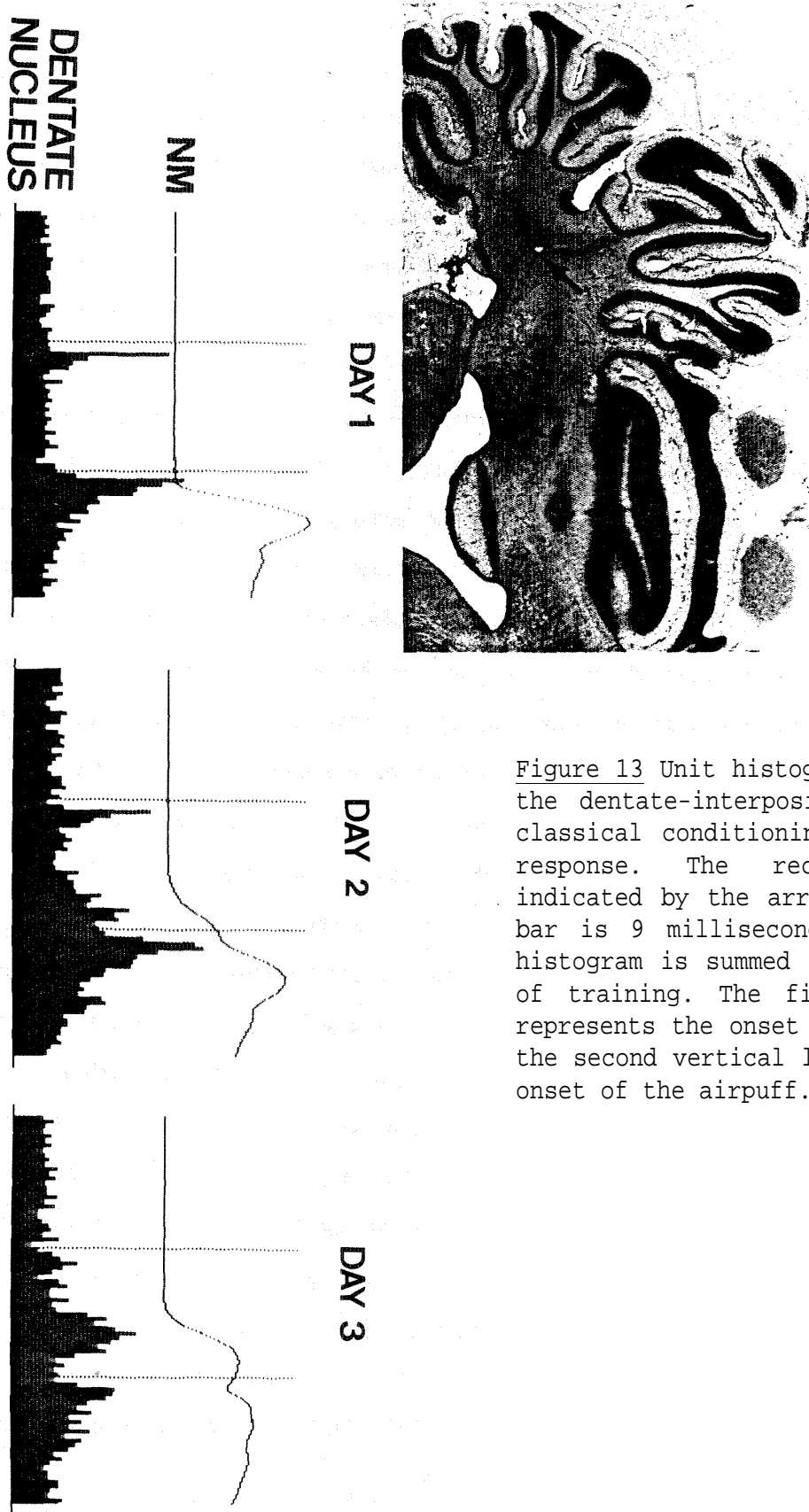

Figure 13 Unit histograms obtained from the dentate-interpositus nuclei during classical conditioning of the eyeblink response. The recording site is indicated by the arrow. Each histogram bar is 9 milliseconds wide, and each histogram is summed over an entire day of training. The first vertical line represents the onset of the tone, while the second vertical line represents the onset of the airpuff.

(78%) of the 54 recording sites at some point within behavioral conditioning. Again the large majority of these responses to the onset of the airpuff were present both before and after the learning of the behavioral response, while a small number significantly decreased (6/42). No responses were found to significantly increase in size during behavioral training. The average onset latency of these responses to the airpuff was 4.6 msec, > 1.9 msec. The possibility that these responses possessed significant auditory components (the airpuff escaping from the outlet nozzle generates a broad band noisy stimulus) was tested in 13 of the animals by misdirecting the airpuff to above the animals head for the first block of unpaired trials. Of the 24 recording sites obtained from these animals, 18 responded to the airpuff. Misdirection of the airpuff away from the cornea to a point of equal distance from the animal's ears was found to abolish or significantly reduce the neuronal response in 9 (50%) of these cases (see Figure 11). Therefore, the neuronal response of some regions of the D-I nuclei are related to the somatosensory components of the airpuff and/or performance of the UCR. The fact that the onset latencies of these responses (4.6 msec) are shorter than the earliest eyelid EMG (M. obicularis oculi) responses to the airpuff (7.5 msec) would rule out feedback from the movement as a cause for the initial portions of these responses. The fact that misdirection of the

airpuff did not, in some cases, abolish the neuronal response to the airpuff indicates that these responses were auditory in nature. Therefore, without such a test, similar responses can only be interpreted with caution. The fact that a number (7) of recording sites responded to the auditory components of the airpuff without giving a noticeable response to the tone CS indicates that a broad band noisy stimulus may be more effective than a pure tone in generating neuronal responses within the deep cerebellar nuclei.

Of the 54 chronic recordings from the deep cerebellar nuclei, 20 (37%) of these developed a neuronal response in the CS period as the animal learned the behavioral response (see Figure 14). These responses were divided into two classifications, those which possessed a standard score (see Methods) of greater than 2.0 on the postcriterion day of training, and those which did not. The responses which were greater than 2.0 standard scores will hereafter be referred to as the larger responses and those which did not will be referred to as the smaller responses. Of the 54 responses, 10 (19%) were of the larger type and 10 (19 %) were of the smaller type. The location of the recording sites which developed a neuronal response within the CS period during acquisition greater than 2.0 standard scores is represented in Figure 16, along with the recording sites which did not develop

any response within the CS period. This figure reveals that the larger responses are found mainly within the medial dentate and interpositus nuclear region. Furthermore, it was found that in only one case in the nine animals which possessed recordings of the larger type, did both the medial and lateral recording electrodes reveal an increase in response in the CS period during learning of the eyeblink response. This result indicates that the regions of learning related neural increase are relatively localized to a subset of the medial dentate and interpositus nuclei.

Figure 14 illustrates the growth of unit activity within the second half of the CS period over the course of learning in comparison to the amplitude of the conditioned response. Note that the neuronal responses in the D-I nuclei increase in close relation to the increase in the size of the conditioned response ( $r = .90$ ). Figure 10 illustrates representative neuronal responses taken from the D-I nuclei. These responses reveal that the temporal firing pattern of neurons in different recording sites can differ significantly, with the neurons in 5 sites responding both to the tone and during the conditioned response and the neurons in 9 sites responding both during performance of the conditioned response and the unconditioned response. The onset latencies of these neuronal responses were found to differ

markedly between recording sites, from consistently occurring before the NM response by 40 - 60 msec (animals 453 and 485, Figures 10 and 12) to occurring after the onset of the NM response by up to 29 msec (animal 538, Figure 10). Of particular interest is the response pattern illustrated in Figure 12. The neurons within this recording did not respond to the CS and only slightly to the UCS when the animal was given unpaired training before learning. However, when the animal was shifted to paired training, a robust neuronal response within the CS period developed as the animal learned the response. This response developed further over subsequent days (days 2 and 3 of acquisition) and came to yield standard scores (see Methods) as high as 12.5. Furthermore, this response preceded the NM response by approximately 38-56 msec throughout the acquisition of the learned response (see Figure 12). The recording site for this electrode was found to lie on the border between the D-I nuclei at approximately A-P 0.5 (see Figure 16). Stimulation through this recording site produced an eyeblink response (eyelid closure and NM extension). A similar response pattern was also found within one other animal (585 see Figure 10), in which the recording site was much the same as that of Figure 12, although in this animal the neurons responded well to the airpuff before behavioral training began.

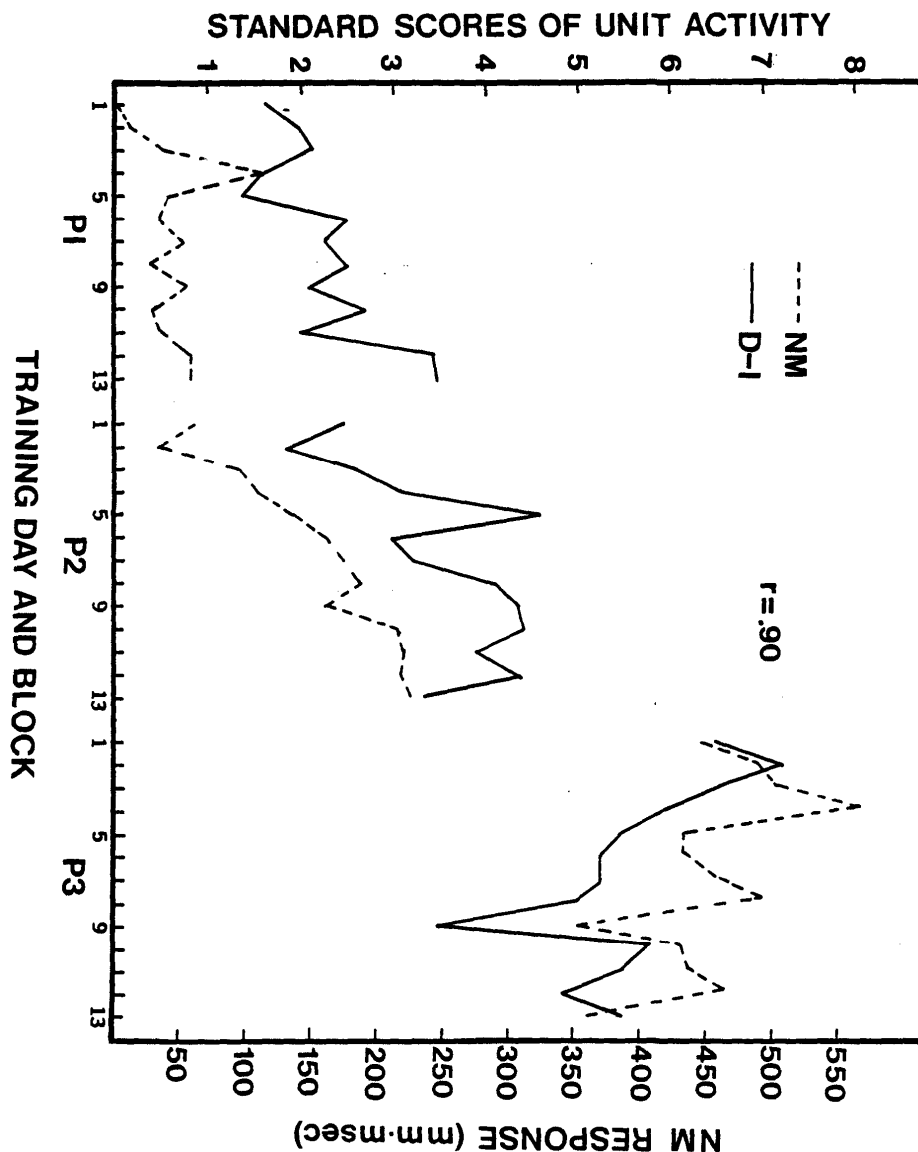

Figure 14 Amplitude of the conditioned response in comparison to the magnitude of dentate-interpositus neuronal activity in the second half of the conditioned stimulus period over the course of learning. 7 of the recording sites which developed larger type responses were utilized for this figure. The other 3 recording sites could not be used for this comparison because the animals from which they were obtained were not trained on the same paradigm. Standard scores were calculated by finding the mean number of action potentials counted for the block of training trials in question, subtracting the number of counts in the corresponding half of the Pre-CS period for that block, and dividing by the standard deviation over the entire training session -  $(CS_{\text{block}} - PCS_{\text{block}}) / (SD \text{ PCS}_{\text{session}})$ . The magnitude of the conditioned response was measured as the area under the curve described by the amplitude-time course of the NM response in millimeter\*milliseconds (see Figure 10).

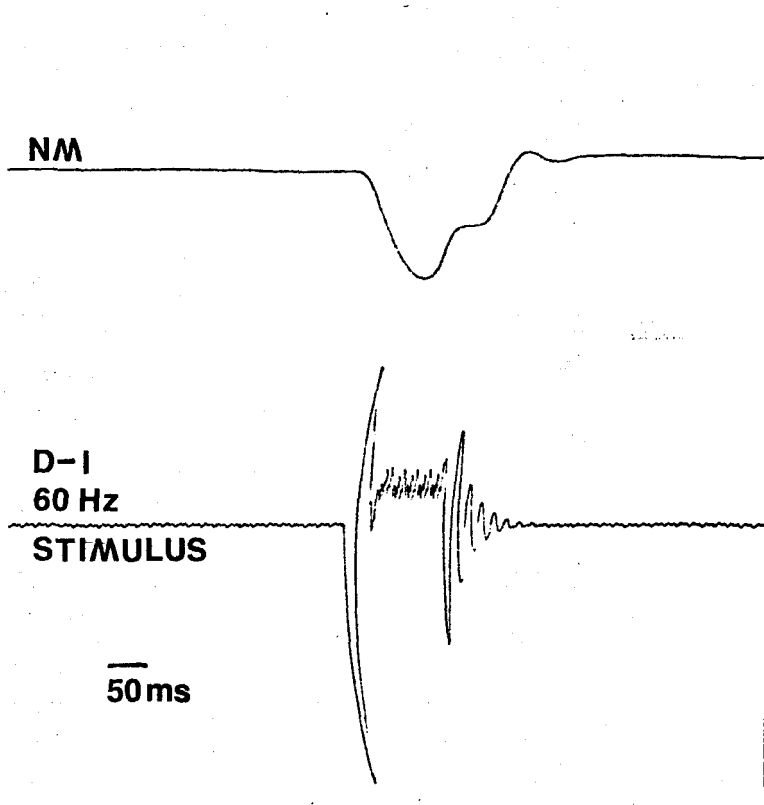

Figure 15 Example of dentate-interpositus stimulation inducing NM extension and eyelid closure. Stimulus was 60 Hz AC, 150 milliseconds, 75  $\mu$ A. Each small division represents 0.5 mm of NM movement across the eyeball.



### Dentate-Interpositus Stimulation

After training ended, each recording site was marked by depositing iron from the stainless steel recording electrodes by passing direct current (DC) of 100 uA for 3 seconds in the awake, unanesthetized animal. It was noticed that in a few cases this stimulus resulted in isolated eyeblinks of the ipsilateral eyelids. To further test this phenomenon, additional animals were stimulated with 150 millisecond pulses of 60 Hz stimulation varying in intensity from 10 uA up to 300 uA (see Methods). Of the 23 recording sites tested, 14 (61%) yielded eyeblinks to either the 60 Hz stimulation or the onset of the 100 uA direct current (see Methods). Other movements which were seen were, postural adjustments, movements of: the eye, vibrissae, ears, forelimbs, and hindlimbs in confirmation of earlier stimulation studies<sup>243,253</sup>.

When eyelid closure and NM extension was the lowest threshold response, increasing the stimulus intensity was more likely to increase the amount of facial musculature involved in the contraction than to recruit muscles not related to facial movements (e.g. hindlimb movements). Measurement of the onset latency in three animals yielded an estimate of 32.2 +/- 5.0 msec for NM and 34.0 +/- 5.5 msec for the eyelids. Eyelid movements were measured as were NM movements, by connecting the wiper arm

of a potentiometer to the upper eyelid with triple 0 suture thread.

The spatial distribution of these stimulation sites, along with ineffective sites, is illustrated in Figure 16. Note that the effective stimulation sites are distributed within the medial dentate-interpositus nuclei corresponding well to the sites which develop neuronal responses during learning of the behavioral response. Indeed, of the 20 recording sites which developed a neuronal response relating to the amplitude-time course of the learned response, 8 out of 9 tested by stimulation yielded eyeblink responses, implying that regions of the deep cerebellar nuclei which develop neuronal responses relating to the performance of the learned response contain neural elements which when activated can cause the response to occur. The reverse implication, that sites which yield eyeblinks when stimulated will develop neuronal responses related to the learned response is true in a smaller, but still significant, proportion of cases (9/14 - 64%). This lower percentage may have its basis in a difference in the neuronal populations stimulated and those which were recorded from, especially since stimulation can activate both axons and cell bodies and chronic recordings from our type of electrodes is largely from cell bodies. Indeed, the stimulation point at which eyeblinks were

elicited with the lowest threshold (10 uA) was from a recording site at the top of the fibers just beneath the interpositus nucleus (see Figure 16). This recording site did not develop a neuronal response relating to the performance of the conditioned response. Of the 9 sites which when stimulated did not yield eyeblinks, 9 (100%) did not develop neuronal responses relating to the onset or topography of the conditioned response. Stimulation (within the same general region of the D-I nuclei) in an additional five untrained animals also yielded eyeblinks, therefore implying that the neuronal circuitry from the deep cerebellar nuclei to the motoneurons controlling eyeblinks (abducens, accessory abducens, facial nuclei) is not dependent upon the learning of this response. However, it is not yet known whether the threshold for stimulation induced eyeblinks changes as the animal learns the response.

It has been reported previously that sectioning of the brainstem as the superior cerebellar peduncle leaves the cerebellum to enter the brainstem abolishes the ability of stimulation of the D-I nuclei to elicit bodily movements<sup>253</sup>. Similarly, we found in two animals that electrolytic lesion of the superior cerebellar peduncle abolished the ability of dentate-interpositus stimulation to elicit eyeblinks at even four times prelesion threshold level.

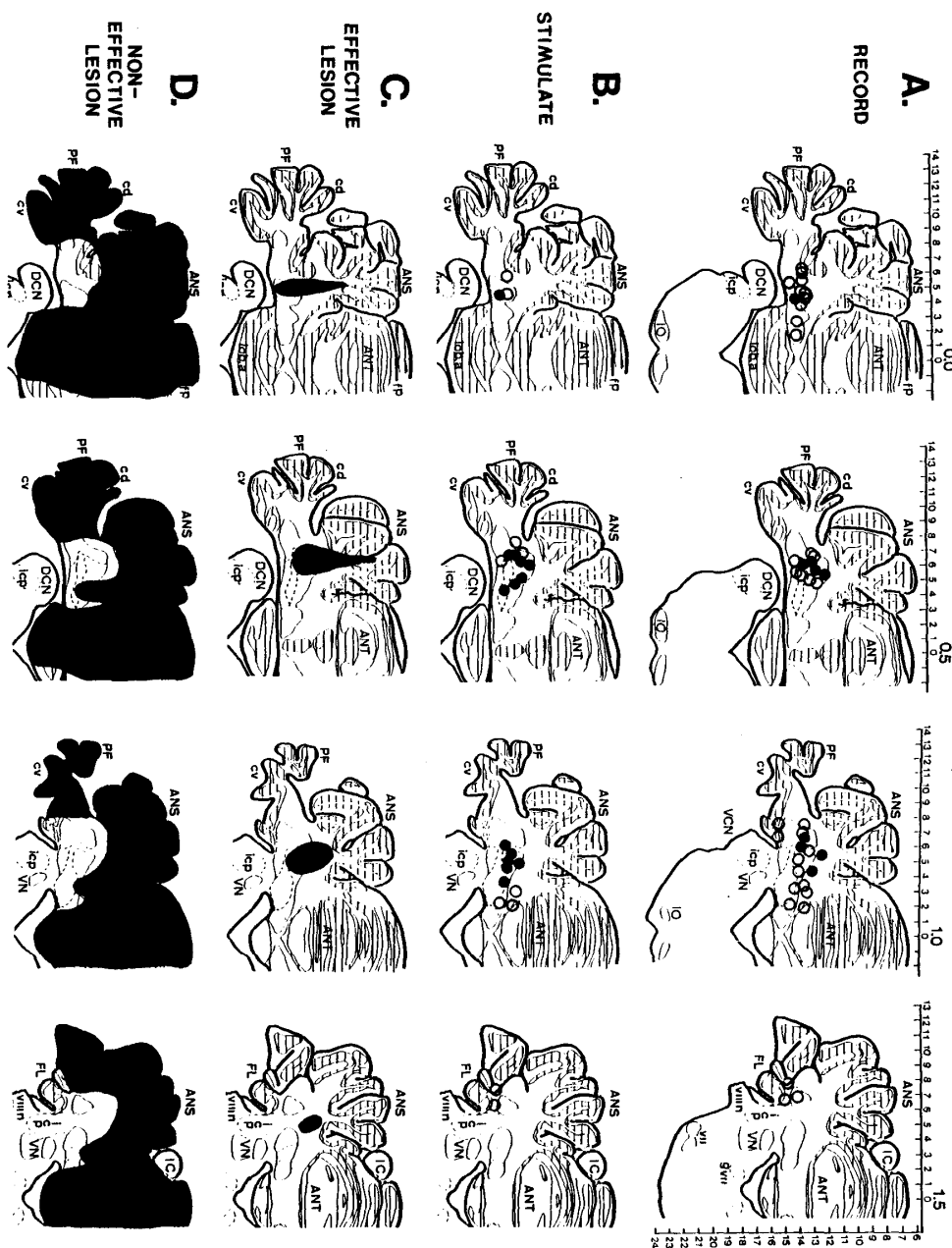

Figure 16 Summary diagram of the chronic recordings sites, stimulation sites, dentate-interpositus lesions, and non-effective lesions of the cerebellar cortex. Part A. illustrates the recording sites (•) which developed neuronal responses within the CS period which were greater than 2 standard scores, as well as the recording sites (O) which did not develop a neuronal response within the CS period. Part B illustrates the sites at which 60 Hz stimulation at 100 uA or the onset of direct current stimulation at 100 uA produces ipsilateral NM extension and eyelid closure. The sites which were ineffective in eliciting eyeblink responses are represented by open dots (O). Part C illustrates a typical stereotaxic lesion of the medial dentate-lateral interpositus nuclear region which abolished the conditioned response. Part D illustrates a composite drawing of aspirations of three animals which were ineffective in abolishing the learned eyeblink response. Note that the medial dentate and lateral interpositus region not only develops neuronal responses related to the performance of the learned response during training (see Figures 7, 10, and 12) but, when stimulated, will elicit eyeblink responses which are dependent, as is the learned response, on the intactness of the superior cerebellar peduncle. Furthermore, lesion of this region of the deep cerebellar nuclei permanently abolishes the learned response, while cortical lesions which circumscribe this region do not. Abbreviations are as in Figure 8.

Recording Results - Discussion BrainstemRecordings

Results of the present study suggest that the regions of the brainstem which may be involved in the control of the learned NM extension-eyeblick response may be relatively localized to a few structures. The neuronal models of the learned behavior found within the seventh nucleus, sixth nucleus, accessory sixth nucleus, and perhaps the surrounding reticular region, are expected since it is these nuclei which directly innervate and control the muscles responsible for the expression of the learned response<sup>26,46,59,100</sup>. The responses recorded medial to the fifth motor nucleus may also have been of similar nature since some animals may develop conditioned responses which would involve the neurons of the fifth motor nucleus<sup>190</sup>.

The "M" type responses recorded within the sensory system of the fifth (principle sensory, spinal nucleus, and mesencephalic nucleus) probably represent proprioceptive or somatosensory feedback of the conditioned movement itself. The latency of these responses (14.0 +/- 33.5 before onset of the NM) correspond well with such an interpretation, given that the eyelids start to close between 20 - 30 milliseconds before the actual extension of the NM<sup>190</sup>.

The "M" type responses recorded from the superior colliculus occurred after the onset of the behavioral response and may be correlated with late contraction of the ocular muscles, or a change in visual or somatosensory stimuli during production of the CR, since it is known that the superior colliculus responds during some types of contractions of the extraocular eye muscles and receives both visual and facial somatosensory information<sup>97,264</sup>.

The stimulus evoked responses found within the superior colliculus may be at least partially explained by the fact that the inferior colliculus is known to connect with this structure<sup>26</sup>. The responses to the airpuff alone found within the superior colliculus may be of a somatosensory nature, since it is known that the superior colliculus possesses a somatotopic map of the facial region<sup>97,264</sup>. Like the superior colliculus, the periaqueductal gray also responded to the tone and airpuff as well as possessing examples of "M" type responses. The presence of all three stimulus types makes both the superior colliculus and the periaqueductal gray putative sites for learning-related plasticity.

The neuronal responses around the decussation of the superior cerebellar peduncle have been reported in an earlier study<sup>170</sup>. This brainstem region is interesting in that lesions of this

region can prevent retention of the conditioned response<sup>68,170</sup>. However, all effective lesions in these studies included at least the lateral aspects of the superior cerebellar peduncle. Thus these lesions may have disrupted essential efferents from the cerebellum.

The fact that the pontine nuclei, tegmental reticular nucleus (Bechterew), the red nucleus, and perhaps the inferior olive, possess neuronal models of the behavior suggest that these nuclei work in conjunction with the cerebellum to control the performance of the learned response. Indeed, some parts of the cerebellum possess striking neuronal models of the learned behavioral response (see above).

The stimulus (tone - airpuff) evoked responses of the brainstem auditory nuclei were expected since both the tone and the airpuff are supra-threshold auditory stimuli. It is interesting to note, however, that almost no responses were found within these brainstem auditory nuclei which correlated with the onset of the behavioral response. This result suggests that if a part of the plasticity encoding this learned response does indeed take the form of a "motor" program, then these brainstem nuclei are not likely to be the site of the critical plasticity. In support of this view it has been found that cells of the central nucleus of the inferior colliculus, the

anteroventral cochlear nucleus and the ventral division to the medial geniculate body respond identically to the conditioned stimulus during signal detection whether or not the learned NM-eyelid response occurs, implying that these regions do not contain the long term neuronal changes which serve to encode this learned response<sup>149,151</sup>.

The reticular region surrounding the abducens, accessory abducens, and facial nucleus was also found to possess stimulus evoked responses to both the tone and to the airpuff. Since neurons at these levels are directly involved in the control of the behavioral response, it is possible that at least part of the long term neuronal changes which allow the CS to elicit the CR may be localized to this region. However, relatively direct auditory connections to the motoneurons controlling the CR are most likely not critical elements in the learned response circuit since such a pathway would probably yield latencies too short to account for the latency of the conditioned response in the present paradigm.

#### Cerebellar Recordings and Stimulation

The present results indicate that selected regions of the ansiform lobule, anterior lobe and lobule C respond in relation to the amplitude-time course of the learned nictitating membrane



(NM) extension-eyelid closure response. Since these recordings were not of a single unit nature, it is not known which class of cells (e.g. Purkinje or granule) generated these responses. However, it is most likely that the majority of the responses represent granule cell activity due to the relatively large number and thick layers of this type of cortical cell<sup>50,75</sup>. However, it is possible that other cortical cells (Purkinje, basket, Golgi, stellate cells) contributed significantly to these responses. For example, it has been found that the Purkinje cells of the anterior lobe respond with an increase in discharge frequency in relation to tone or light signaled prompt arm-wrist movements in the monkey<sup>280</sup>. The onset of the neuronal responses within the ansiform cortex often significantly covaried (up to values of .98) with the onset of the learned eyeblink response, suggesting that these responses were intimately related to the performance of the conditioned response. The average onset latency of these responses was 29.3 +/- 16.5 msec before the onset of the behavioral NM response. However, within this paradigm other facial movements are known to be involved, with EMG activity within the eyelid musculature (M. obicularis oculi) occurring at the shortest latency (29.5 +/- 8.2 msec before the NM response). The fact that the granule cells of the ansiform (Crus I) region of the cerebellar cortex receive a direct projection from neurons within the fifth

sensory nuclei and respond well to light cutaneous stimulation of the upper face and large mystacial vibrissae with a latency of 3-5 milliseconds<sup>42,254,255,262</sup> indicates that the neuronal responses from the cerebellar cortex reported in the present study may contain significant somatosensory or proprioceptive feedback components from the production of the movement itself. Since the dentate-interpositus nuclei also receive a direct projection from the fifth sensory nuclei, this may also hold true for some of the neural activity within these nuclei<sup>50</sup>. This feedback component would be most likely to contribute to the neural responses which occurred near ( $\pm$  20 msec) the onset of the NM response. However, not all of the responses from the chronic or acute recordings can be completely explained in this manner, since we found that in some cases the dentate-interpositus neuronal activity consistently preceded the NM response by 40 - 60 milliseconds. Similarly, the pattern of neuronal activity within the D-I nuclei often did not "model" the unconditioned eyeblink, but did respond in relation to the amplitude-time course of the learned eyeblink (see Figure 10 and 12). Thach has reported earlier that the neurons of the D-I nuclei fire in relation to tone, light signaled prompt arm-wrist movements in the monkey. The distribution of onset latencies for neurons in the dentate nucleus were found to precede the movement by approximately 90 milliseconds, preceding onset

latency distributions of EMG, interpositus, Purkinje cells of the anterior lobe, motor cortex<sup>279,280,281,282</sup>, and red nucleus<sup>229</sup>. However, considerable overlap between all of these distributions was evident. Furthermore, it has recently been reported that in monkeys trained to perform an arm movement sequence in response to a visual or auditory signal, neurons of the dentate nucleus not only fire in relation to the occurrence of learned response, but also in relation to the occurrence of the signaling stimulus. This response to the signal to move is found to extinguish as the animals behavioral response extinguished when reward is withheld<sup>51</sup>.

Recordings from the brainstem (see above) have indicated that the nuclei connected with the cerebellum (pontine nuclei, reticular tegmental nucleus of the pons (Bechterew), red nucleus, inferior olive) also respond in relation to the amplitude-time course of the conditioned response, although latency measurements could not be made. Taken together, these data indicate that the cerebellum and its related brainstem nuclei are intimately involved in the ongoing production of prompt, learned motor responses initiated in response to an auditory or visual stimulus. Indeed, it has been reported that cooling of the dentate nucleus in monkeys well trained to perform an arm-wrist flexion task causes the execution of the task to be delayed by

90-250 msec<sup>37,38,201</sup>. Furthermore, cooling of the dentate in a monkey who has just learned a new variation of the task reverts the animal's learned arm movements back to prelearning levels of performance<sup>118</sup>.

Many of the recording sites of our own study were from the region of the interpositus nucleus, which may have contributed to the relative late onset latency of some of our chronic recordings, since interpositus neurons respond closer to the onset, both prior to and just after, of prompt arm movements than do dentate neurons in the monkey and cat<sup>40,279,281,282</sup>. In agreement with this, the two recording sites which revealed responses which preceded the NM response most substantially in time were from the border of the medial dentate and the lateral interpositus nuclei (see Figures 10 and 12).

The fact that stimulation of the D-I nuclei can elicit eyeblink responses indicates that this region contains neural elements which when activated can ultimately excite the motoneurons controlling the eyeblink response, as has been reported earlier<sup>243,253</sup>. Furthermore, the fact that superior cerebellar peduncle lesions abolish the ability of D-I stimulation to elicit eyeblinks implies that is the activation of the projecting neurons of these nuclei which is causing the eyeblinks. It is interesting to note that the same manipulation

which eliminates the ability of the cerebellum to produce eyeblinks (SCP lesion) also permanently eliminates the ability of the animal to perform learned eyeblinks<sup>194</sup>.

## CHAPTER 5 - EXPERIMENTS ON THE CRITICAL INPUTS TO THE CEREBELLUM

From the previous chapters, we have seen that the medial dentate-lateral interpositus nuclei appear to be essential components of the neuronal circuitry responsible for the learning and/or performance of classically conditioned eyeblink responses in the rabbit. If this hypothesis is true, then there must exist some set of inputs into this neural region which are critical for the production of the learned response. Furthermore, if the essential changes in neuronal function encoding the learned eyeblink response occur within the deep cerebellar nuclei, then at least part of the essential inputs would be expected to carry what could be called as auditory, or CS specific, information. Other Inputs may be: somatosensory for the occurrence of the airpuff, somatosensory for the feedback control of the response, and "pain" for the motivation for learning the response.

The known auditory inputs to the cerebellum are mainly from the inferior colliculus - lateral pontine nuclear route<sup>76,146</sup>. However, another pathway has been described which travels through the caudal portion of the medial accessory olive<sup>88</sup>. The pontine nuclei project exclusively through the middle cerebellar peduncle (MCP) into the cerebellum with the input to the deep cerebellar nuclei assumed to be largely collaterals of the

fibers destined for the cortex<sup>25,26,50,75</sup>. The main projection of these fibers carrying auditory information is to the vermal, or midline, cerebellar cortex, although a small projection also exists to the hemispheres<sup>79,84,146,258</sup>. A small direct projection from the cochlear nucleus also exists, although this projection is small and mainly to the midline cortex<sup>119</sup>. In chapter 3, I showed that the midline cerebellar cortex is not essential for the retention of the learned eyeblink response, indicating that the major region of auditory input is not essential for the learned eyeblink response.

From chapter 4, we have seen that some recording sites within the dentate-interpositus nuclei respond in relation to the onset of the tone, implying that these cells receive some form of auditory input. However, many of these responses were small compared with those of the brainstem auditory nuclei (compare Figure 1 with Figure 10, Chapter 4), especially in light of the fact that the tone used in the present studies was 85 dB in intensity; a supra-threshold stimulus which appears to activate many auditory responsive neurons (see Figures 5 and 6, Chapter 4). However, if these neurons of the dentate-interpositus nuclei do in fact drive the learned eyeblink response, then it would be undesirable for these cells to respond with a short latency to the tone, especially before learning, since this would yield

alpha, or unlearned, eyeblink responses to the CS. Thus the auditory input to the site(s) of neuronal plasticity may contain a sub-threshold or small input from the CS circuitry.

The inferior olive is another important input into the deep cerebellar nuclei which presumably projects as collaterals of a more pronounced projection to the cerebellar cortex<sup>11,33,50,64,75,102</sup>. Furthermore, the inferior olive has been suggested to be involved in the learning and/or production of some forms of learned motor responses<sup>1,125,176,177</sup>, and indeed, lesions of the inferior olive often mimic the effects of lesion of the deep cerebellar nuclei<sup>43,148,176,177,259</sup>. For example, Llinas et al. have reported that lesion of the inferior olive (IO) by the selective neurotoxin 3-acetylpyridine and harmaline prevent rats from recovering after lesion of the vestibular apparatus on one side (see introduction - hemilabyrinthectomy<sup>176,177</sup>). Furthermore, IO lesions, after recovery, immediately return the animal to the pre-compensated state. Lesions of the fastigial nuclei have a similar effect, while lesions of the cerebellar cortex do not<sup>43,176,177</sup>.

Therefore, we undertook the present experiments and observations in an effort to elucidate the essential inputs into the deep cerebellar nuclei.





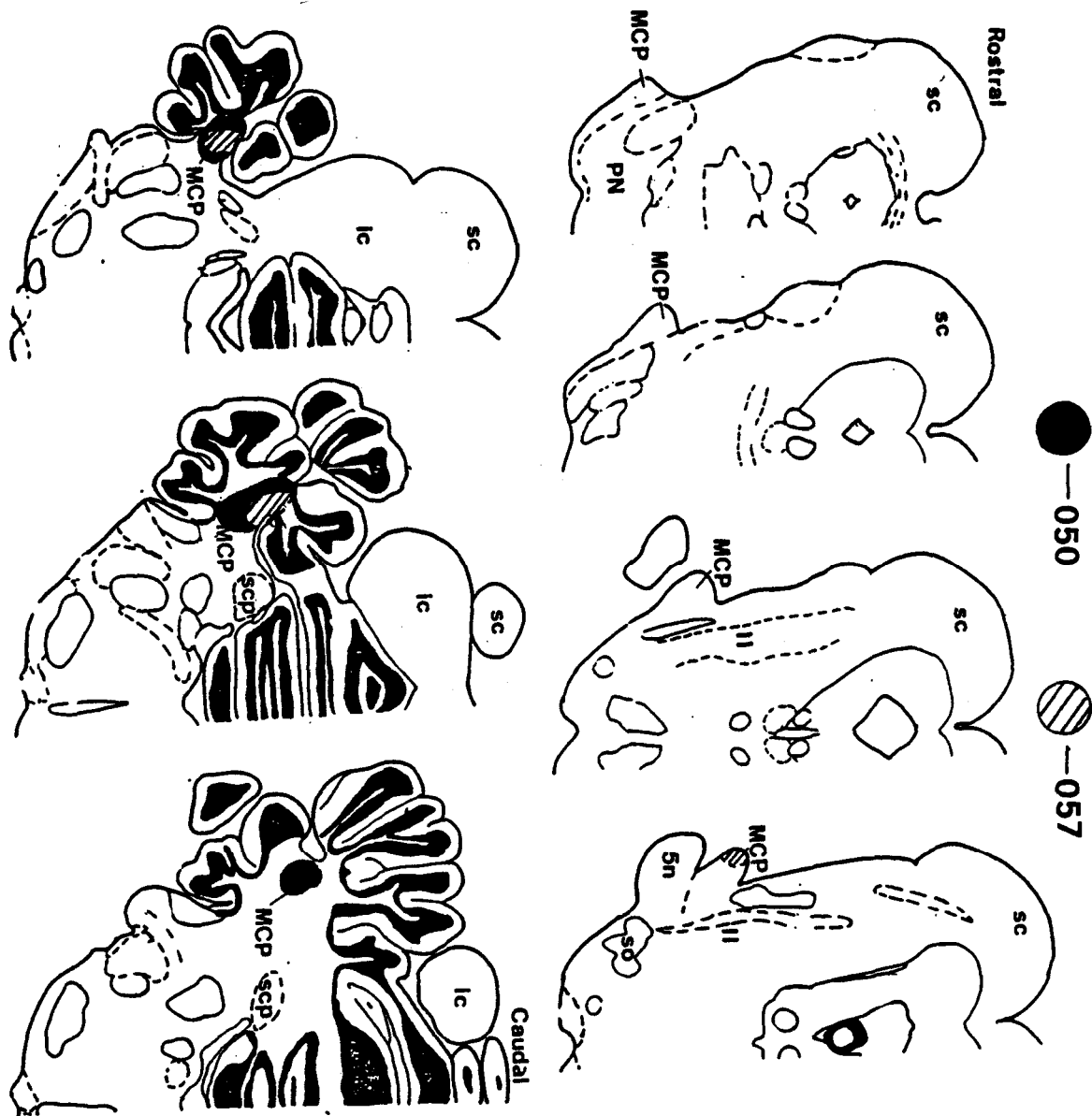

Figure 2 Histological reconstruction of lesions of the middle cerebellar peduncle (the axons of the pontine nuclei as they course to the cerebellum) in two animals. One lesion is illustrated by slanted lines, while the other is illustrated by black. See Chapter 4 for abbreviations.

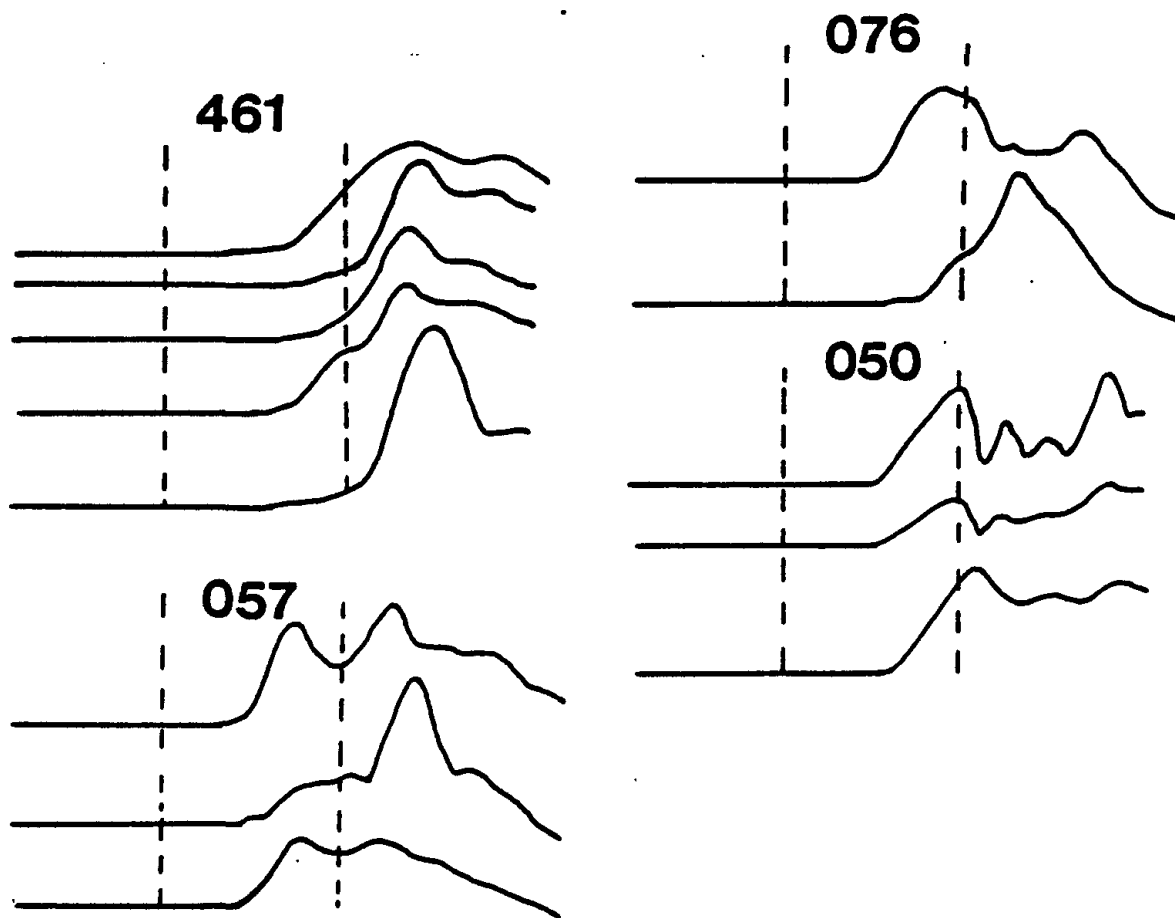

Figure 3 Effect of lesion of the middle cerebellar peduncle on the conditioned eyeblink response. The number above each set is the animal's identification number. Each trace is the averaged NM response over an entire session of training. The top trace is the pre-lesion day of training with each subsequent trace being consecutive days after the lesion. The first vertical line represents the onset of the tone, while the second vertical line represents the onset of the airpuff. The MCP lesion is found not to permanently abolish the eyeblink response in any of the animals, although the conditioned responses of animal 461 were reduced on the first two days after the lesion.

### Middle Cerebellar Peduncle Lesions

Lesions limited to the middle cerebellar peduncle (MCP) were obtained in four animals. In addition Brian Swanson, while working in our laboratory, has also lesioned the MCP in an additional 5 animals. In eight of the nine animals the lesion of the MCP did not abolish the conditioned response, however, none of these lesions were found to include the entire MCP. Most of these lesions included from 1/3 to 2/3 of the lateral portions of the MCP (see Figures 1 and 2). In one animal (81-461) the lesion was found to be of the more rostro-medial portion of the MCP (see Figure 1). The effect in this animal was to temporarily diminish both the CR amplitude and frequency over the first and second days after the lesion. The CR recovered on the third day after the lesion, although on the fourth day, it again showed a diminished amplitude and frequency (see Figure 3).

These results indicate that lesions of up to the lateral two-thirds of the MCP are not sufficient to abolish the CR; however, the lesion in animal number 81-461 indicates that some input information which is critical to the CR may travel through the MCP. More complete lesions of the MCP are necessary before a final decision can be made. Complete lesions of the MCP only are very difficult to obtain because it is bordered by critical elements of the brain: the nerve of the fifth nuclei, the

inferior cerebellar peduncle, the superior cerebellar peduncle, and the lateral Lemniscus. This experiment is still in progress.

#### Inferior Collicular Lesions

Bilateral lesions of the inferior colliculus were attempted in two animals. Both animals had been given one day of training, during which time they both reached criterion performance, before aspiration of the inferior (and caudal superior) colliculi. After a week of recovery, both animals were tested. Neither animal showed retention of the eye-blink response, although both animals relearned the response within one to two sessions of retraining. Histology revealed that both animals had removal of approximately the upper 65 - 75 % of the inferior colliculi and removal of the caudal half of the superior colliculi.

#### Cochlear nucleus

Three animals well trained in the eyeblink response were tested for the ability to utilize auditory input from one ear only. This was achieved by delivering the CS through a tube inserted into only one of the ears. There was very little possibility that the animal could perceive the CS with the other ear. It was found that the animals adapted to the unilateral CS

input in either ear within one to two blocks of training trials, even though they had been trained with a bilateral CS input.

Lesions of the Inferior Olivary Complex and Inferior Cerebellar Peduncle

Note: This work was done by myself in conjunction with Carl Baier, who performed this research as part of his undergraduate honors thesis.

Lesions in the vicinity of, and including various portions of, the inferior olivary complex (10) were obtained in ten animals. The animals with lesions in the vicinity of the 10 were divided into three categories: 1. lesions effective in abolishing of the conditioned response (CR) without recovery; 2. lesions partially effective, in that the CR was smaller after the lesion, but recovered at some point to at least 75% of its original value; 3. lesions that were ineffective, i.e., CRs which were at least 75% of pre-lesion values the first session after the lesion was performed. Of the 10 animals with lesions of the 10, only two animals were found to have lesions effective in abolishing the CR (see Table 1, animals # 83-093 and 82-105). These two animals contained lesions of somewhat varying locations, with one lesion being of the rostromedial portion of

the 10 (see Figures 4,5,6,7 and 10), and the other including the caudal portions of the medial accessory olive (MAO) (see Figure 10). However, lesions in other animals which included the caudal MAO were not effective in completely abolishing the conditioned response (see Table 1 and Figure 9). The animals with lesions in the vicinity of this portion of the 10 showed varying signs of motor symptoms, with one animal (83-033) showing severe head and eye rotation. Despite these disturbances, this animal, when tested, could perform near normal CRs, although these CRs would diminish over the course of a training session. This diminishing effect may have represented a general motor fatigue due to the abnormalities induced by the lesion. Thus, this animal's (and animal #82-105) UCR was also- found to be reduced compared to pre-lesion levels, suggesting a non-specific effect on the learned eye-blinks. Recovery of an additional week revealed a disappearance of the general motor disturbances and a reappearance of normal conditioned responses, although continued training resulted in a reduction in both the CR and the UCR.

#### Inferior Cerebellar Peduncle

In studying the effects of MCP lesions on the conditioned response, Brian Swanson found that lesions just medial to the MCP were effective in immediately abolishing the conditioned response without affecting the unconditioned eyeblink response.

Microscopic examination of these lesions revealed that in 4 animals the lesions included significant portions of the ICP (and sometimes medial portions of the MCP) and did not involve the superior cerebellar peduncle (SCP). Lesions of the MCP alone in 5 animals was found not to abolish the learned eyeblink response, as stated above. Thus it would appear that some critical input or output to or from the cerebellum travels through the ICP. This pathway may be the fibers from the contralateral 10 since these axons make up a large part of the ICP.



Table 1. Effect of lesions of the inferior olive on learned eyeblinking responses.

Animal #	Day	CR: mm	UR: mm	MAO Ros.	MAO Caud.	DAO Med.	DAO Lat.	PO Med.	PO Lat.	RF
82-044	P3 L1	3.89 5.98	6.8 7.39	-	-	-	-	-	-	+
82-567	P2 L1	5.94 4.12	8.4 10.72	-	-	-	-	-	-	+
83-095	R2	3.84	10.4	-	-	-	-	-	-	+
82-105	P3 L1 L2 L3 L4 R1	3.99 1.4 0.8 1.09 0.57 2.11	7.93 6.79 5.15 5.02 11.07 4.23	-	+	++	-	-	-	+
82-389	P2 L1	4.81 4.76	5.4 8.98	-	++	-	-	-	-	++
82-565	P2 L1	7.88 4.32	6.08 8.35	++	+	++	-	-	-	+
83-033	P3 L1 AFTER ONE WEEK L5 L6 L7 L8	6.75 2.65  4.97 5.11 1.73 2.98	8.95 7.35  9.44 8.01 3.86 4.92	-	+	-	-	-	-	+
82-583	P2 L1	3.51 5.25	8.4 8.24	-	-	-	+	-	+	+
82-585	P3 L1	5.87 3.83	6.31 7.69	-	-	-	+	-	+	+
83-093	P3 L1 L2 L3 L4 R1 R2 R3 R4 L5	4.73 1.51 0.90 0.64 0.46 0.87 0.37 1.47 0.34 0.73	10.06 9.01 10.76 8.95 14.39 8.5 11.64 14.32 6.83 8.86	+	-	+	-	+	-	++

DAO - Dorsal Accessory Olive; MAO - Medial Accessory Olive; PO - Principal Olive; RF - Reticular Formation

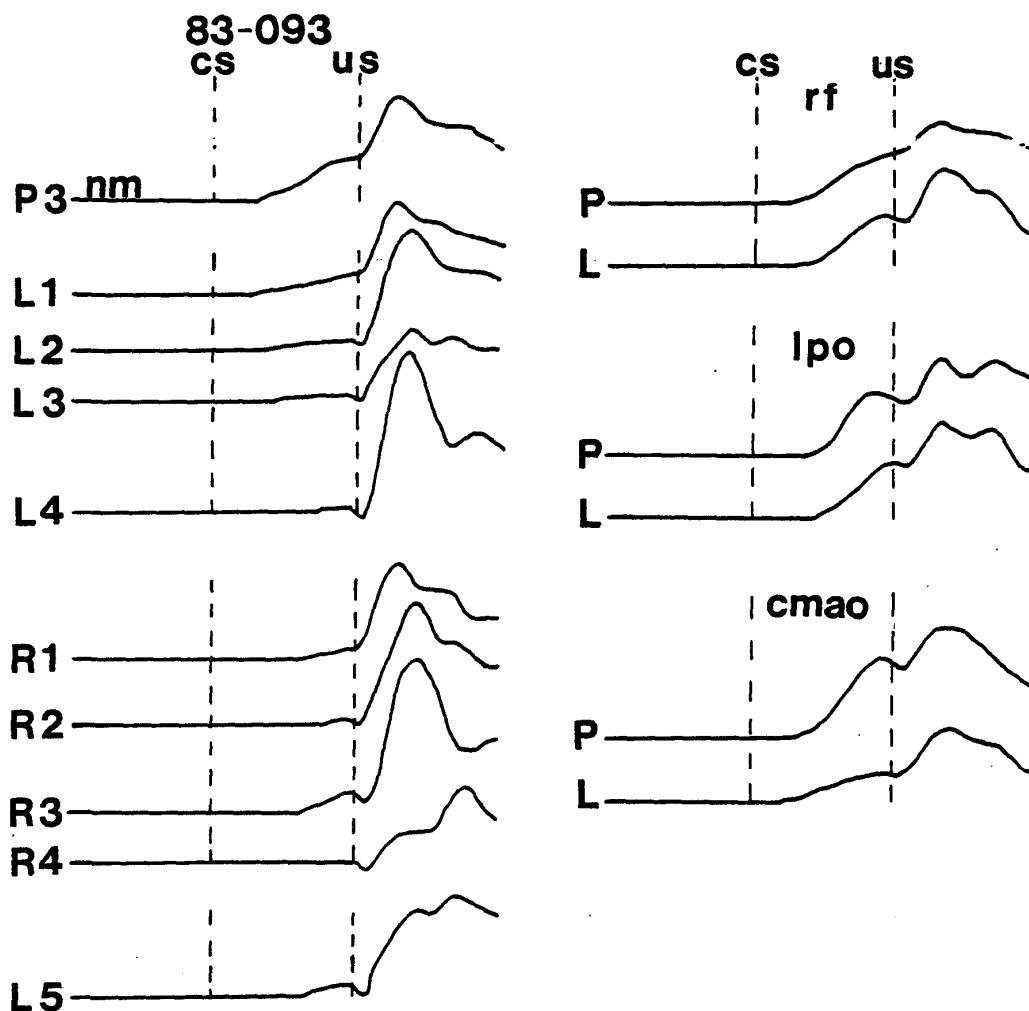

Figure 4 Effects of lesion of different parts of the inferior olivary complex on the conditioned nictitating membrane responses. Animal number 83-093 possessed a bilateral lesion of the rostromedial inferior olivary complex. The conditioned response in this animal was found to be diminished immediately after the lesion and to decrement thereafter. Four days of training on the right NM-eyelid failed to establish a consistent conditioned response. Abbreviations are as follows: P3 -third day of paired training before the lesion; L1 - L4 - four days of paired training to the left eyelids after the lesion; R1 - R5 ~ four days of training to the right eyelids after the lesion; L5 - an additional day of training to the left eyelids. Lesions of other regions of the inferior olive and reticular formation were found to either temporarily diminish the conditioned response, or to have no noticeable effect. On the right are the average NM responses before and after the lesion for animals with three classification of lesion: rf - lesions restricted to the reticular formation (n=3), lpo - lesions of the lateral principal olive (n=2), cmao - lesions of the caudal portions of the medial accessory olive. The prelesion day of training is denoted by P\_ and the post lesion days of training are denoted by an L\_. All traces are grand averages of NM responses over all paired trials for the appropriate day(s) for all animals in that group.

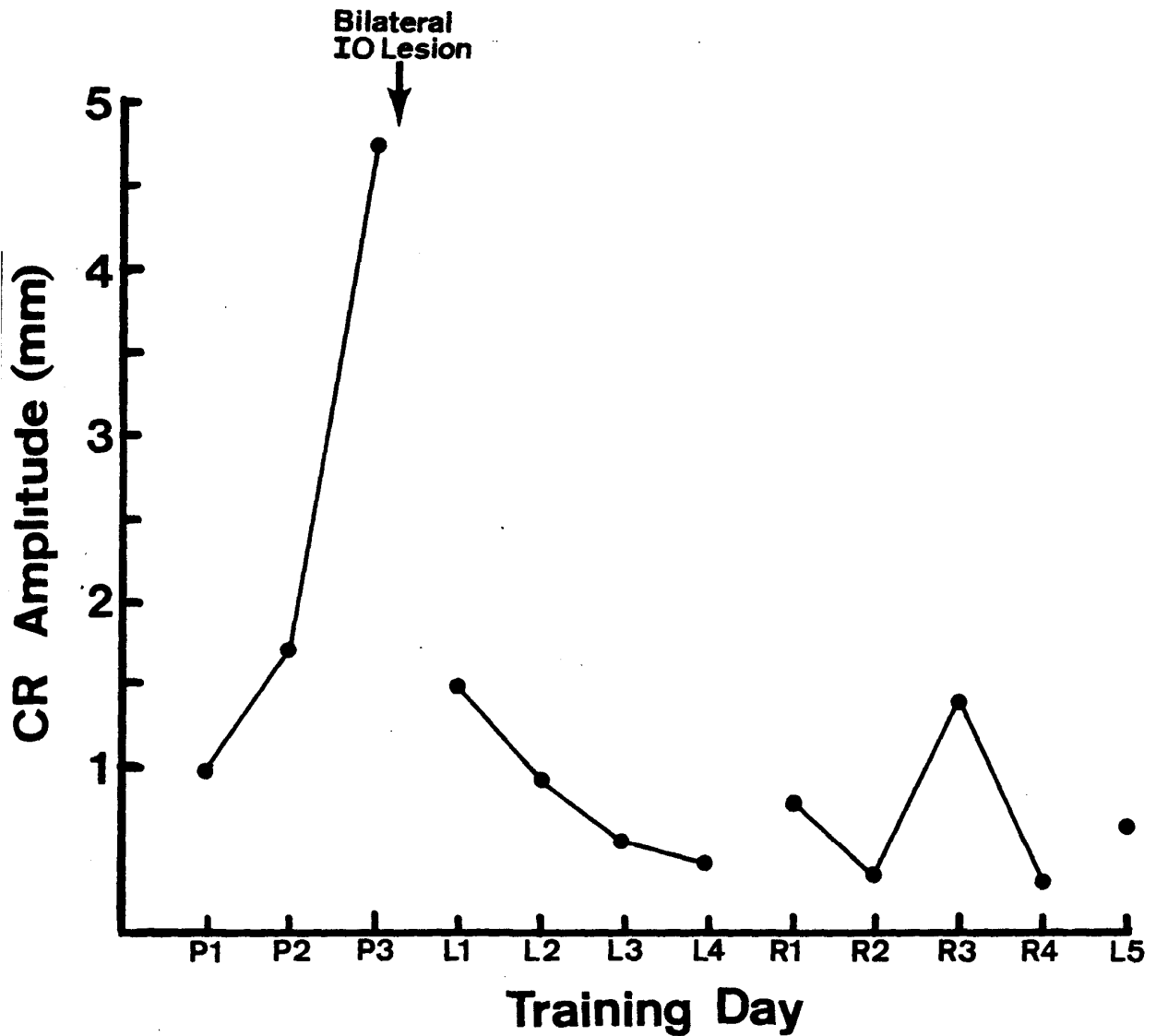

Figure 5 Amplitude of the conditioned response in animal 83-093 before and after lesion of the rostro-medial inferior olivary complex. Each data point is the average of the nictitating membrane responses on all paired trials of that day of training. P1 - P3 refer to the three days of paired training to the left NM-eyelid before the lesion was made. L1 - L4 represent the four days of post-lesion training to the left NM-eyelid, while R1 - R4 represent the four days of paired training to the right NM-eyelid. L5 is an additional day of training to the left NM-eyelid.

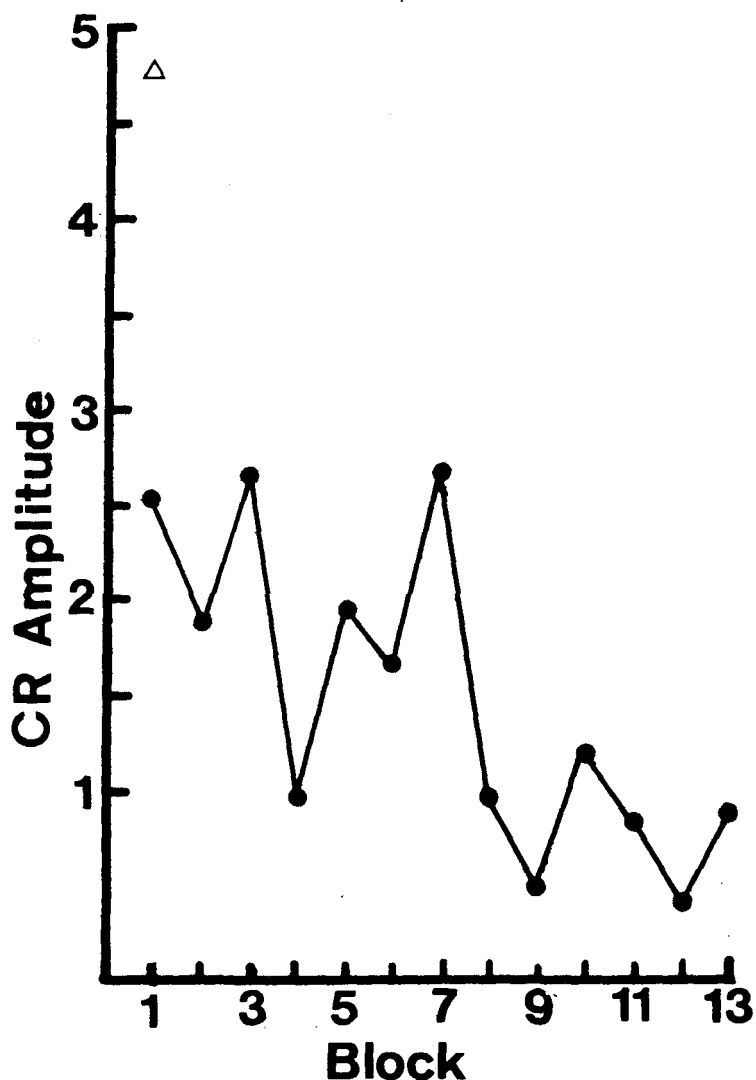

Figure 6 Amplitude of the conditioned response on the first day of training after the lesion of the rostro-medial inferior olive in animal number 83-093. On the abscissa is the block number of eight paired trials, the ordinate represents the amplitude of the conditioned response, in millimeters of NM extension. The triangle represents the amplitude of conditioned responding on the last day of paired training before the lesion was performed. Note that the NM responses start out diminished and then grow worse from there.

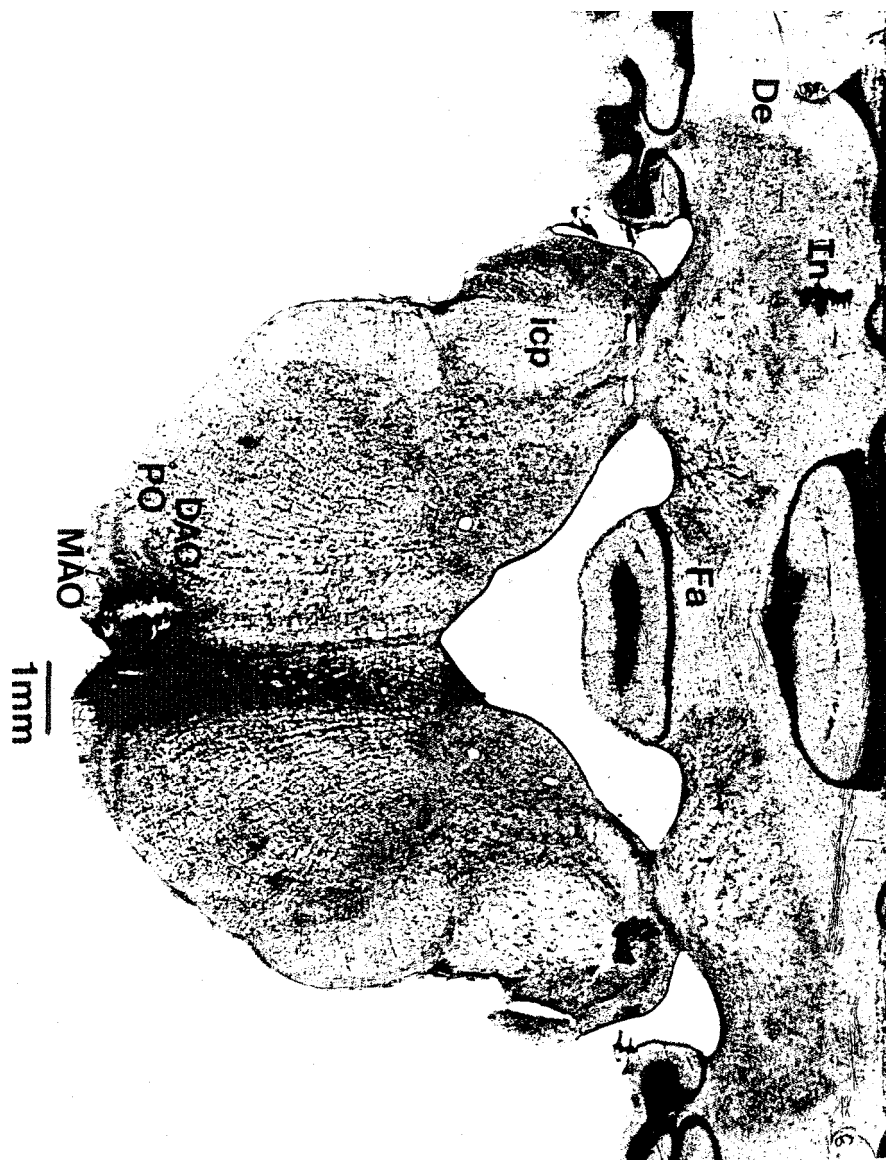

Figure 7 Photomicrograph of a bilateral inferior olivary lesion in animal number 83-093. Pre-lesion training was to the left NM-eyelid. The portion of the lesion extending into the reticular formation on the right is largely due to the electrode tract, which was present before the lesion was made. Abbreviations are as follows: DAO - dorsal accessory olive; De - dentate nucleus; Fa - fastigial nucleus; icp - inferior cerebellar peduncle; In - interpositus nucleus (anterior); MAO - medial accessory olive; PO - principle olive. The cells of the inferior olive project completely contralaterally through the inferior cerebellar peduncle under the deep cerebellar nuclei, turning dorsally just anterior to these nuclei, and then caudally over the superior portions of the deep nuclei. Thus the axons of the inferior olive form the anterior and dorsal borders of portions of the dentate-interpositus nuclei.

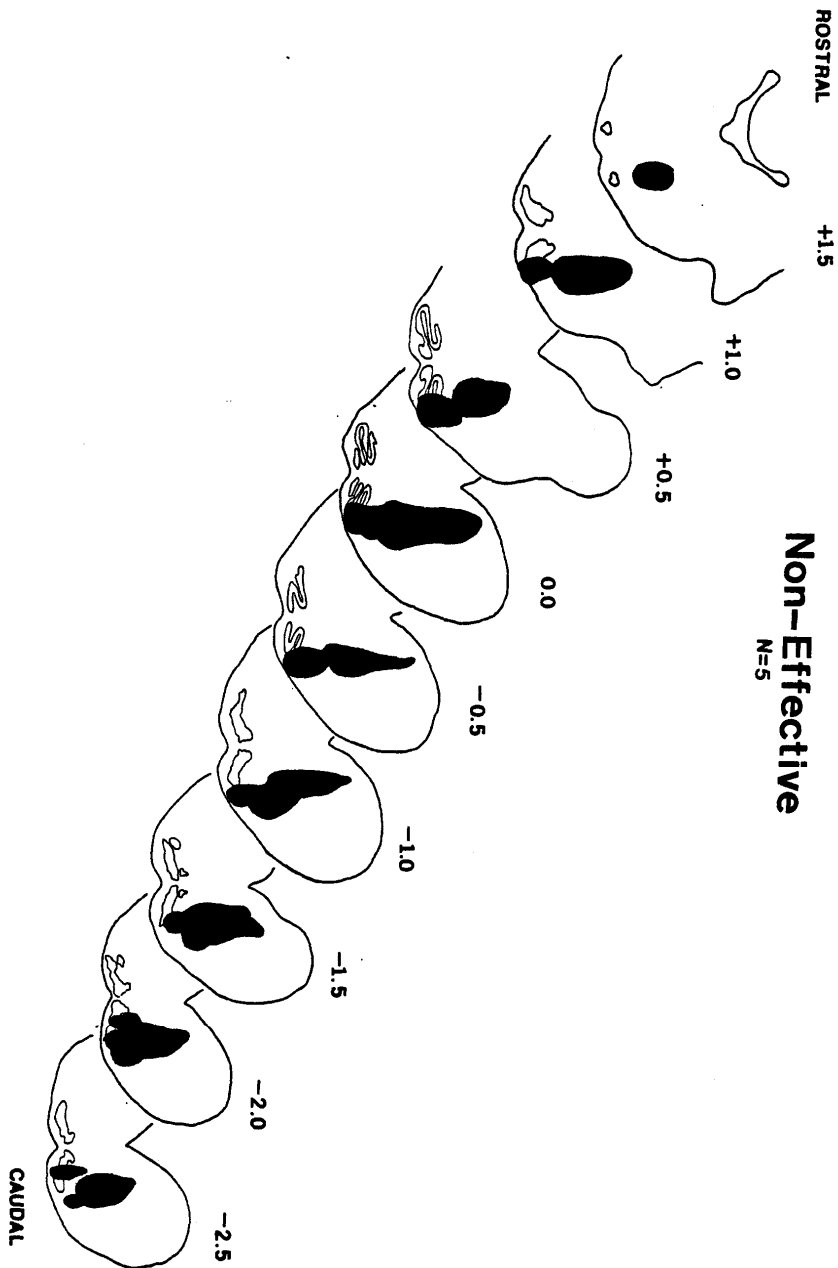

Figure 8 Composite of lesions in the vicinity of the inferior olivary complex which were ineffective in abolishing the learned eyeblink response. The lesioned area includes the lateral portions of the principal olive and of the medial accessory olive. The number above each section represents the number of millimeters that the section is anterior to lambda.

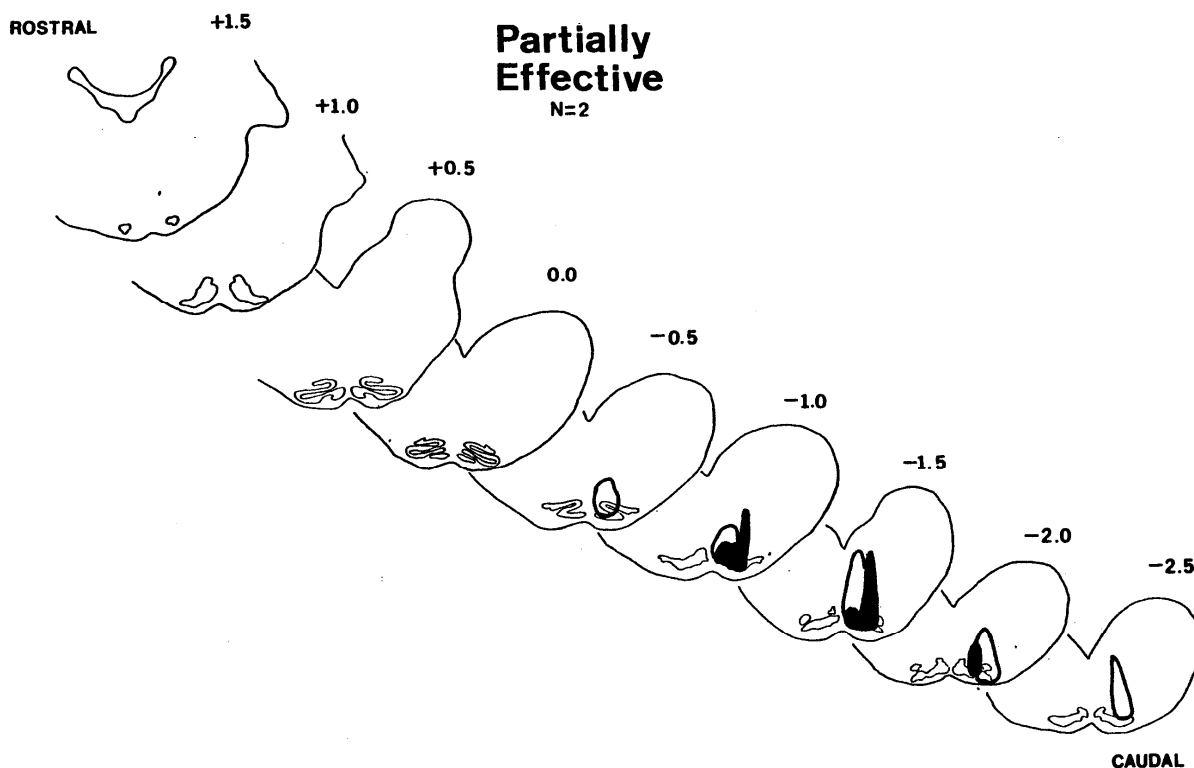

Figure 9 Lesions (n=2) in the vicinity of the inferior olivary complex which abolished or diminished the learned eyeblink response immediately after the lesion, with subsequent recovery occurring at some point later in training. Contained within the partially effective region is the caudal portions of the medial accessory olive and the medial portions of the caudal - dorsal accessory olive. The numbers above each section represent the number of millimeters that the section is anterior to lambda.

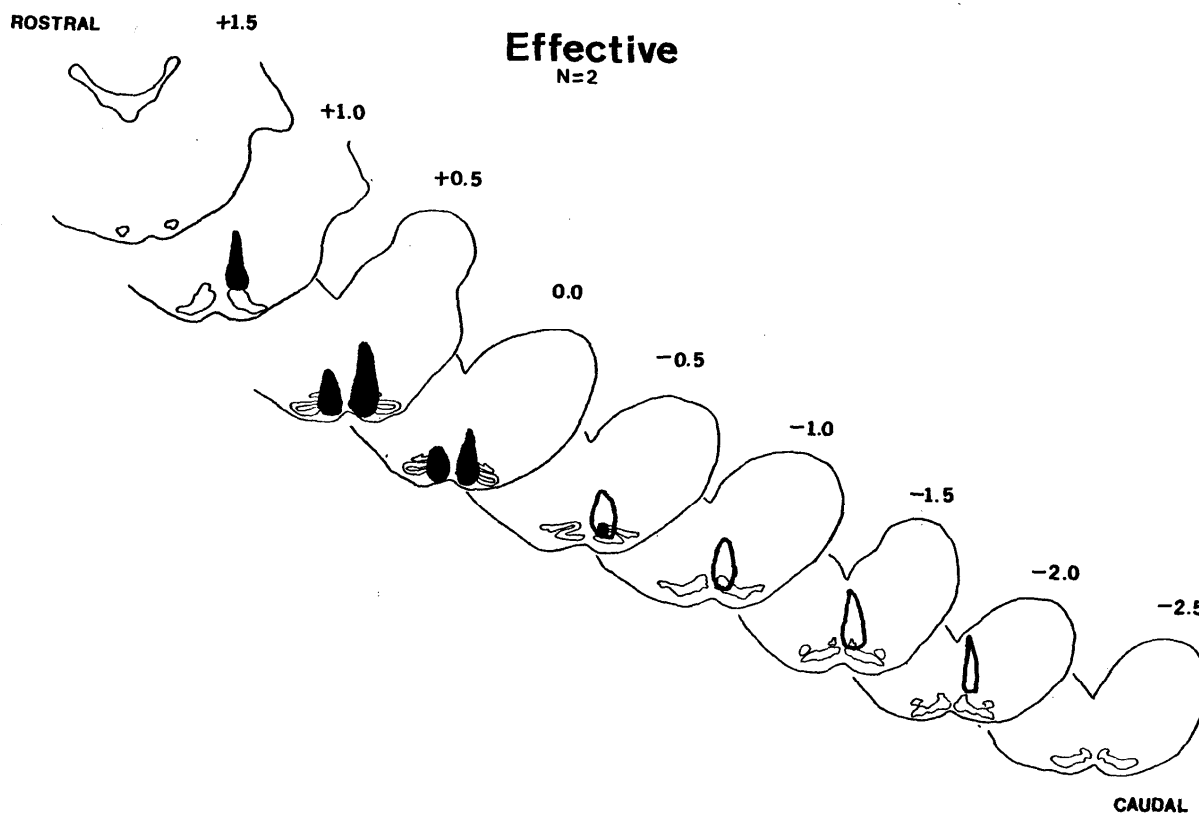

Figure 10 Effective (n=2) lesions in the vicinity of the inferior olivary complex which abolished or severely impaired the learned eyeblink response without effecting the unconditioned eyeblink response. Included in the effective region is the rostro-medial inferior olive and the medial portions of the caudal medial accessory olive. The numbers above each section represent the number of millimeters anterior to lambda.





Figure 11 Composite of effective (red), partially effective (blue), and ineffective (black) regions of the inferior olivary complex. The numbers above each section represent number of millimeters anterior to lambda. Note that the rostro-medial inferior olive is contained within the effective region, the lateral principal olive is contained within the ineffective region, and the caudal medial accessory olive is within the partially effective region. Abbreviations are as follows: DAO - dorsal accessory olive; dc - dorsal cap; dl - dorsal lamina of the PO; MAO - medial accessory olive; PO - principle olive; vl - ventral lamina of the PO. See Figures 8, 9, and 10 for the full extent of the lesions.

## Discussion

The results of the present experiments indicate that the rostro-medial inferior olivary complex is critically involved in the maintenance of the conditioned eyeblink response. Furthermore, the possibility that the inferior colliculus and pontine nuclei also contribute to the conditioned response is raised since lesions of these two neural regions could affect the conditioned response. The fact that animals with lesions of the inferior colliculus and MCP retained or relearned the eyeblink response does not rule out these two neuronal structures as being involved in the production of the CR, since in neither case were the lesions complete. The fact that either cochlear nucleus may be utilized indicates that wherever the critical changes in neuronal function occurs, this neural region must be capable of activation by auditory input from either ear. Alternatively, there may be parallel changes in neural function, parts of which have only unilateral auditory input, both of which can cause the learned eyeblink response.

The caudal medial accessory olive (cMAO) is known to respond to auditory stimuli and project to the fastigial nuclei and midline portions of the cerebellar cortex<sup>88</sup>. Complete removal of the this region of the cerebellum is known not to abolish the learned eyeblink response(see Chapter 3). Similarly, lesion of

the caudal portions of the MAO did not eliminate the ability of one animal (83-033) to produce normal conditioned responses. Therefore, the caudal MAO - vermal cerebellar connections do not appear to be critical for the retention of the learned eyeblink response.

The lateral half of the principle and dorsal accessory olive were lesioned in two animals with no effect on the conditioned eyeblink response (see Figures 4 and 8). This portion of the inferior olive projects to the cerebellar cortex in a parasagittal zone (zone D of Voogd)<sup>295,296,297</sup> which includes Crus II of the ansiform cortex<sup>5,33,102,159</sup>. It also projects to, and receives reciprocal projections from, the dentate nucleus<sup>11,64,102,104,266</sup> (see Figure 12). Crus II of the ansiform cortex is known to respond well to perioral, and not periocular, cutaneous stimuli<sup>254,255</sup>. Lesions of the lateral dentate nucleus, which receives projections from Crus II and the P0, do not abolish the learned eyeblink (see chapter 3). Thus, it would appear that the lateral P0 - lateral dentate - Crus II (lateral ansiform cortex in the rabbit) cerebellar system is not essentially involved in the production of learned eyeblinks.

The rostro-medial portions of the inferior olivary complex project to the medial dentate and interpositus nuclei, i.e., the critical region of the deep cerebellar nuclei<sup>11,64,102</sup> (see Figure

12). This region of the inferior olivary complex (rostromedial DAO, MAO and PO) also projects to the parasagittal zones of CI, C2, and C3 of Voogd (which includes Crus I of the ansiform cortex). This region of the cerebellar cortex also projects to the medial dentate and interpositus nuclei and is known to receive a direct projection from the trigeminal nuclei concerning cutaneous input from the face<sup>254,255</sup>. Furthermore, the rostromedial portion of the DAO (and PO) also receives fine cutaneous input from the face through the trigeminal nuclei<sup>13,56,88,298</sup> and projects mainly to the anterior interpositus nucleus<sup>11,64,102</sup>. The rostromedial portions of the MAO project largely to the posterior interpositus nuclei and does not respond well to cutaneous stimulation of the face<sup>11,64,88,102</sup>. This region of the olivary complex (rostro-medial) was successfully lesioned in one animal (83-093). The learned eyeblinks in this animal were severely retarded at the beginning of post-lesion training and progressively diminished with additional training. Thus, the rostromedial inferior olive - medial dentate and interpositus - ansiform cortex (Crus I) neuronal system would appear to be essential for the retention of this response. Furthermore, it is interesting to note that the portion of the inferior olivary complex which receives facial cutaneous information projects to the anterior, and not the posterior, interpositus nucleus. This may indicate that the anterior

interpositus nucleus (and medial dentate?) may be the critical portion of the deep cerebellar nuclei for the production of this eyeblink response.

The fact that the lesion of this region of the 10 did not have its full effect on the conditioned response immediately after the lesion implies that the lesion effect may be partially dependent upon additional training, or the time elapsed after the lesion was made. One way in which the lesion effect may be partially dependent upon additional training is that critical information concerning the occurrence of the UCS may travel through this portion of the 10 to the critical region of the D-I nuclei, and therefore the learned eyeblink response may extinguish when this input is removed (see Figure 21, Chapter 3).

The theories of cerebellar cortical function put forth by Brindley<sup>24</sup>, Marr<sup>186</sup>, and Albus<sup>1</sup> predicted that the 10 input could be a "teacher" while the parallel fiber input could be a "learner" in that the conjunctive stimulation of the climbing fiber and parallel fiber inputs to the Purkinje cells was envisioned to cause a change in the synaptic efficacy of the parallel fiber input. Thus the 10 input, in a classical conditioning situation, would be expected to correspond to the UCS input, while the parallel fiber input would represent the CS

input. Although it is known that cerebellar cortical lesions do not abolish classically conditioned responses (see Chapter 3), a similar type of situation may arise within the deep cerebellar nuclei, since these nuclei receive collaterals from the inputs into the cerebellar cortex. However, an alternative, and perhaps more likely, explanation is that the lesion of this region of the 10 induces a malfunction of the critical region of the D-I nuclei and that this malfunction requires a certain amount of time to be fully expressed. This hypothesis is given support by the fact that it has been reported that removal of the 10 input into the cerebellum can drastically change the normal functioning of the cerebellar cortex<sup>8,73,103,123,127</sup>. It is entirely possible that a similar process occurs within the critical region of the D-I nuclei. This experiment is still in progress, and we hope to be able to distinguish between these two alternatives.

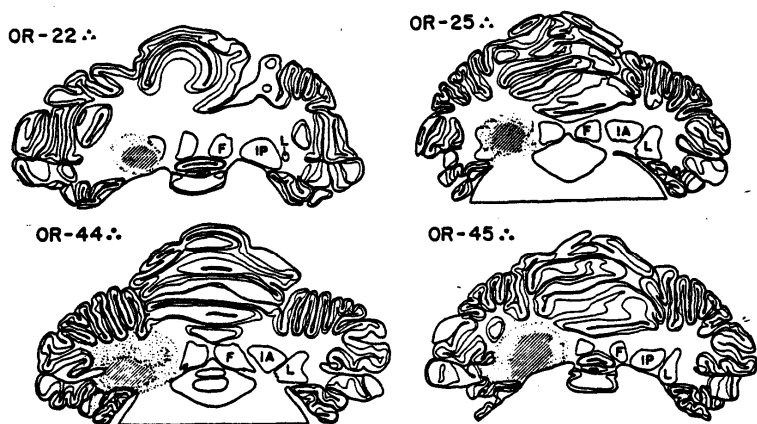

Fig. 2. These transverse sections through the cerebellum illustrate the centers of injection in 6 experimental animals. The size of the dense deposit of HRP (hatchings) and the extent of the surrounding lighter staining (stipplings) vary according to the volume of injection. In some cases, the deep parts of some cortical folia are covered by the light reaction. It is assumed that the retrograde transport of the marker protein originates mostly from the heavily labeled area of the injections. Symbols next to cat number correspond to the distributions in the olive for each case in Fig. 3. Courville et al. Brain Research 130 (1977) 405-419.

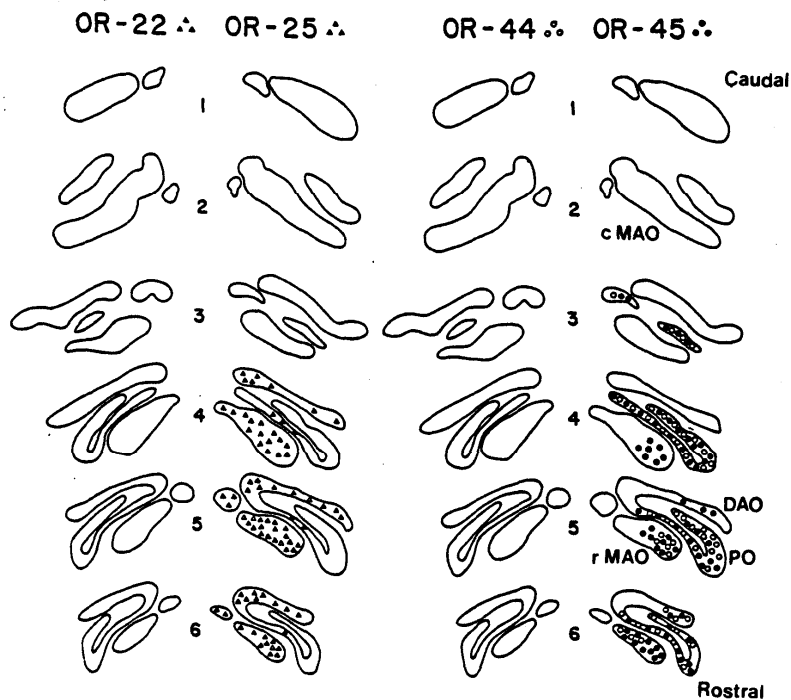

Figure 12 Retrograde labeling of the inferior olivary complex after injections of horseradish peroxidase within various portions of the deep cerebellar nuclei. Upper diagrams illustrate injection regions of the horseradish peroxidase. The lower diagrams illustrate the region of retrograde labeling within the inferior olivary complex. The results of four animals are illustrated; OR-22 - open triangles; OR-25 - closed triangles; OR-44 - open circles; OR-45 - closed circles. The injection site in OR-25 is very similar to an effective lesion of the medial dentate and lateral interpositus nuclei. Retrograde labeling is found within the rostral portions of the dorsal and medial accessory olives (DAO and MAO). A more lateral injection (OR-44) including the lateral dentate nucleus, which is known not to be essential for learned eyeblink responses (see Chapter 3) causes retrograde labeling of the principal olive (PO), a region also known not to be essential for the learned eyeblink response (see Figures 8 and 11). Figure adapted from Courville et al. Brain Research 130 (1977) 405-419.

## CHAPTER 6 - CEREBELLUM AND CLASSICAL CONDITIONING - SUMMARY

Involvement of the cerebellum in classical conditioning has been known for a number of years, ever since Popov first found that removal of the cerebellum impeded or prevented the formation of conditioned avoidance reflexes of one limb (conditioned leg flexion) in 1929<sup>237</sup>. Later studies revealed that conditioned salivary<sup>160,172</sup> responses were also abolished or severely impaired by removal of the cerebellum. Gambaryan reported that incomplete removal of the cerebellum (deep nuclei remained somewhat intact) did not change the normal acquisition of the learned leg flexion response in the dog, although complete removal of the cerebellum in one (maybe two) animals was also found not to block the ability of the dog(s) to eventually learn the response (they were however, 2-3 times slower than normal)<sup>85</sup>. However, more recent (1969) investigations by Fanardjian et al. have found that removal of the cerebellum abolishes the learned specific leg flexion response in the dog, and does not recover for up to one and a half years<sup>81,144</sup>. A number of conditioning stimuli were used including a bell, metronome, light, and mechanical stimulation<sup>81</sup>, indicating that the deficit was not due to a deficit in a specific sensory pathway. However, it is reported that these animals do show a chaotic generalized motor activity in response to the conditioned stimuli, with the conditioned leg



no longer maintaining its dominant position. This result led these authors to suggest that the cerebellum is important for the inhibition of non-appropriate responses. However, I have found in our paradigm that cerebellar lesions abolish conditioned eyeblinks and do not lead to a generalized motor activity of the rabbit in response to the CS. Similarly, Donegan et al. in our laboratory have found that rabbits trained to flex the hind limbs in response to a tone also do not reveal any overt musculature activity in response to the tone after cerebellar ablation (Donegan et al., unpublished observations). Recent investigations by Lavond et al. have shown that bilateral stereotaxic lesions of the dentate-interpositus nuclei which abolish the ability of the animals to learn eyeblink responses, do not affect the learning of heart rate deceleration (Lavond, Lincoln, McCormick, and Thompson, Unpublished observations). Learned heart rate deceleration has been taken to be a measure of a quickly acquired (approximately 15 trials) conditioned "state", "fear", or "arousal" which precedes the learning of the somatic responses (e.g. conditioned eyeblink or leg flexion, both of which require approximately 50 - 200 trials to learn). Thus it may be that the chaotic, non-specific movements made by the dogs in response to the CS represented a motor expression of conditioned "fear", since the UCS in these studies was a leg shock, which may have been quite noxious (its exact intensity

was not reported).

My own investigations have shown that the classically conditioned eyeblink response is also abolished by lesioning of the dentate-interpositus nuclei or their output, without effecting reflexive eyeblinks or the ability of the animal to learn the response on the contralateral side. This abolition can be complete (down to 0% CRs post-lesion in some animals) and permanent (one animal was trained three months without relearning the response). Furthermore, this effect is not consistently found with lesions limited to the cerebellar cortex. Donegan et al. have further shown that removal of the neocerebellum, including the dentate-interpositus nuclei, also abolishes the bilaterally learned leg flexion of the rabbit (rabbits move both legs together; i.e. they hop). Interestingly, when the UCS (leg shock) is shifted to the leg contralateral to the lesion, the animal learns the response with both legs. However, if the leg shock is shifted back to the leg ipsilateral to the lesion, both of the legs extinguish. Thus the inability of the animal to perform the conditioned response with the ipsilateral UCS is not due to a change in any of the motor components shared by the two leg flexion systems (ipsilateral and contralateral). For example, hypotonia, which is known to result from lesions of the neocerebellum would not be a

legitimate cause to prevent the animal from performing the conditioned response, since this is shared by the two learning systems.

Thus, it would appear that the dentate-interpositus nuclei are essential for the learning and retention of ipsilateral classically conditioned somatic responses. Furthermore, this involvement shows at least some CS, UCS and species generality. Further my investigations have revealed that activation of the output neurons of the dentate-interpositus nuclei can lead to eyeblink responses of the same amplitude as the learned eyeblink responses. Furthermore, chronic recordings from this region of the medial dentate-interpositus nuclei at times have revealed a growth in neuronal activity which parallels the learning of the eyeblink response. Assuming that these neural responses are representative of the activity of the projecting neurons which can cause eyeblinks, we can then say that the projecting neurons of the dentate-interpositus nuclei are both capable of producing (stimulation), active during production of (recordings), and essential for production of (lesions) the learned eyeblink response. In other words the medial dentate and/or lateral interpositus appears to be an essential pathway by which learned eyeblink responses are produced. Therefore, given the present knowledge of the connections of the dentate-interpositus nuclei,

we can hypothesis on the neuronal circuitry involved in the learning of this response (see Figure 1). The medial dentate and interpositus region receives projections from a number of locations, including the pontine nuclei, inferior olive, and the sensory nuclei of the fifth<sup>15,17,25,26,29,45,50,120,133,262,302,306</sup>. These two nuclei project out of the cerebellum via the superior cerebellar peduncle to the red nucleus, the ventral lateral thalamus and various other nuclei (e.g. reticular tegmental nucleus of the pons, Bechterew, pontine nuclei, sensory nuclei of the fifth, locus coeruleus, inferior olive)<sup>26,50</sup>. The red nucleus is known to project to the dorso-inter-mediate portions of the facial nucleus, which innervates the upper facial region including the eyelid muscles (M. obicularis oculi) and therefore may activate eyeblinks of the external eyelids. Movements of the NM are controlled by the accessory abducens and abducens nuclei, which innervate the retractor bulbi muscle behind the eyeball<sup>100</sup>. It is not yet known how the dentate-interpositus nuclei can activate these nuclei, although a pathway through the red nucleus, reticular formation, or coupling between the facial nucleus and the accessory abducens nucleus are good possibilities. In chapters 3 and 4 it was found that the lateral portions of the interpositus nucleus was critically involved in the learned eyeblink response. This region of the cerebellar deep nuclei project to the rostral red nucleus,

indicating that the rostral, rather than the caudal, red nucleus may be more important for the learned eyeblink response.

The classical pathway for auditory information to reach the cerebellum is via the inferior colliculus - lateral pontine nuclei connection<sup>79,146</sup>. Therefore, since the deep nuclei receive both auditory and somatosensory information and are capable of producing the learned response, they may contain part or all of the neuronal changes which serve to encode the learning of this response. Alternatively, the essential plasticity may be afferent to the cerebellum, with the cerebellum forming an essential efferent link. Even in this case the cerebellum is an important neural integration center which could compare the command to respond and the production of the response, thereby controlling the topography of the learned eyeblink response.

Figure 2 illustrates a hypothetical working diagram of some important functional connections with cerebellar involvement in the production of the learned eyeblink response. First, the conditioned eyeblink response is initiated by the occurrence of the tone. This initiation occurs either at the dentate-interpositus (D-I) nuclei or within some afferent for which the D-I nuclei are an obligatory pathway to reach the motoneurons controlling the CR. The activation of the D-I leads to, relatively directly, activation of the CR motoneurons (6<sup>tn</sup>,

accessory 6<sup>th</sup>, 7<sup>th</sup>) which leads to contraction of the musculature controlling the CR (M. obicularis oculi, retractor bulbi). The production of the conditioned response leads to direct positive feedback through the sensory 5th - D-I connection and negative feedback from the sensory 5th - granule cell - Purkinje cell - D-I connections. Thus the cerebellar cortical output may be thought of as an inhibitory sculpturing of the ongoing activity of the D-I nuclei. The output of the nuclei from this sensory feedback further shapes the ongoing production of the conditioned response. Thus it is hypothesized that the D-I nuclei are not only involved in the initiation of learned response but are also intimately involved in the ongoing feedback control of the learned response, as has been previously suggested by a number of authors<sup>38,75,76,77</sup>. What evidence do I have for this hypothetical circuit? Besides the fact that these connections are known to exist neuroanatomically, my evidence is as follows:

- 1). From recording studies, neurons within the D-I nuclei and ansiform cortex respond in a pattern which is related to the amplitude-time course of the learned response. These responses possess varying onset latencies with a number of responses occurring sufficiently late to be explained by feedback from the response (see Chapter 4);
- 2). Stimulation of the D-I nuclei can elicit eyeblink responses, while lesions abolish these responses (see Chapters 3 and 4);
- 3). Lesions of the ansiform cortex,

which receives a large projection from the fifth sensory nuclei, can lead to a difficulty on the part of the animal in maintaining the learned eyelid closure. Since the fifth sensory projection to the D-I nuclei may exist as collaterals of this cortical projection, these collaterals would presumably degenerate upon removal of the ansiform cortex (see Chapter 3). Thus removal of the ansiform cortex may lead to shorter duration eyeblinks due to a lack of sensory feedback into the D-I nuclei. Alternatively, the ansiform cortex itself may contain significant neuronal analysis which is critical for the proper shape of the learned response.

The hypothesis that sensory feedback is critical in the production of learned movements is an old one. However, it has been shown that deafferentation does not prevent the learning or performance of a number of tasks<sup>153,154,265,270,271,272,273,274,276,</sup> although these tasks are performed more poorly if visual feedback is limited or blocked<sup>271,272</sup>. Therefore, although sensory feedback may play an important role, it is nonessential for the learning and/or performance of some learned responses. Of particular interest is the effect of deafferentation on the production of learned signaled ballistic arm-wrist movements in the monkey, since these movements are somewhat similar to the signaled eyeblinks in rabbits. Terzuolo et al. have found that

dorsal root section in the monkey disrupted the normal pattern of EMG activity and its relation to the velocity and acceleration characteristics of the ballistic movements, particularly that of the antagonistic muscle<sup>276</sup>. Thus, even within very fast movements (200 milliseconds), the parameters of the movements are not completely preprogrammed, but depend upon sensory feedback from the production of movement. The D-I nuclei would appear to be an ideal place for such a feedback influence to occur, given its afferent and efferent connections with sensory and motor nuclei.



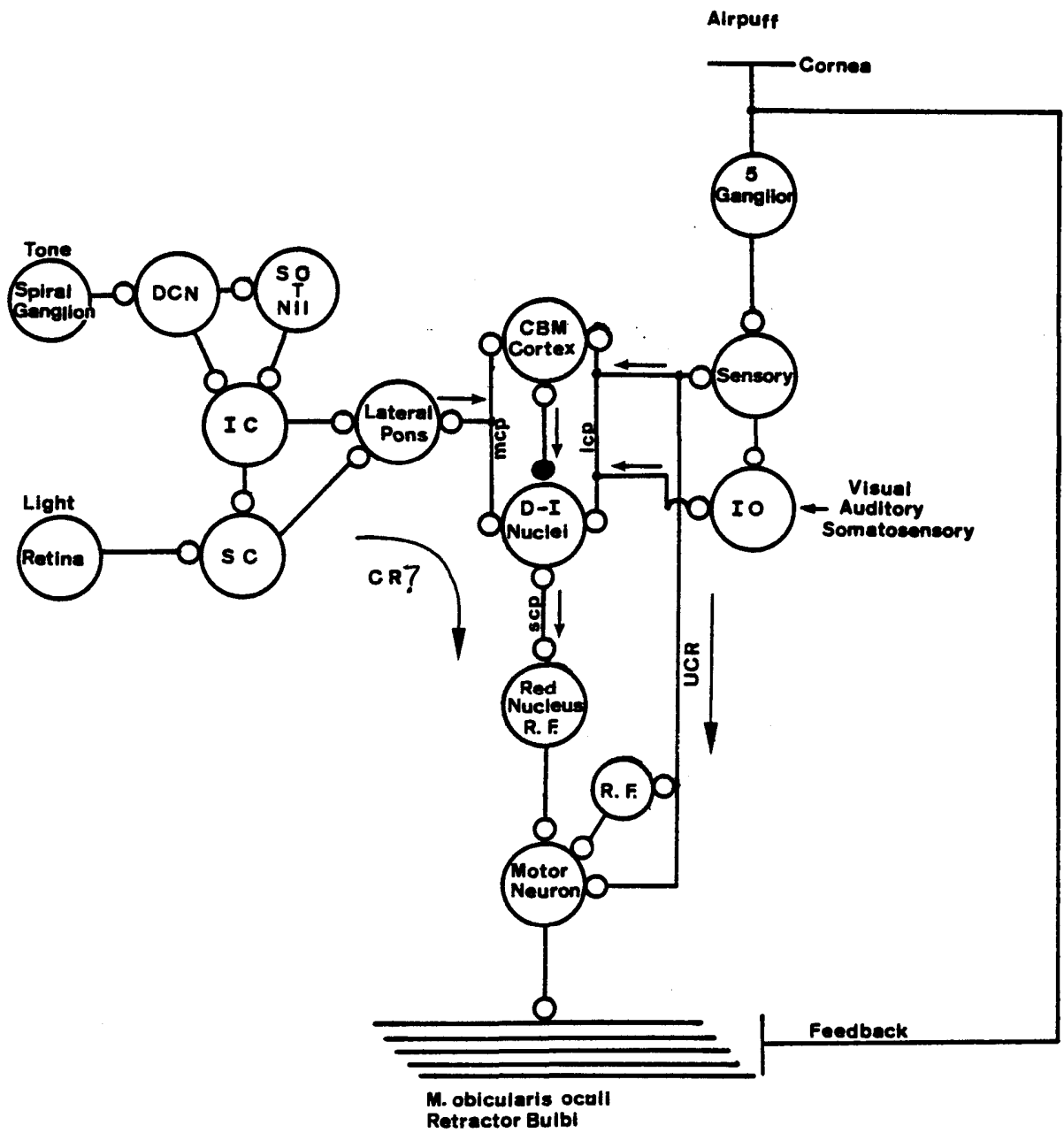

Figure 1 Diagram illustrating some of the neuronal connections which may be involved in the learning, retention, and performance of the nictitating membrane-eyelid response. The dentate-interpositus (D-I) nuclei and cerebellar cortex (ansiform) are known to receive input from the pontine nuclei through the middle cerebellar peduncle (mcp) and the inferior olivary complex (10) through the inferior cerebellar peduncle (icp). Sensory projections from the fifth sensory nuclei also occur through the icp. The 10 receives information concerning somatosensory, auditory, and visual stimuli, as well as receiving a reciprocal connection from the D-I nuclei. The D-I nuclei project through the superior cerebellar peduncle (scp) to the red nucleus, which is known to project to the facial nucleus. The major muscles involved in the conditioned response are the retractor bulbi muscle for retraction of the eyeball (hence extension of the NM) and the obicularis oculi muscle for closure of the external eyelids. An auditory pathway to the cerebellum from the inferior colliculus (IC) - lateral pontine nuclei route is also known to exist. Many of the connections concerning the cerebellum are reciprocal, although they are usually much stronger in one direction than in the other. The arrows indicate the direction of the stronger projection. Somatosensory information concerning movements of the face and the occurrence of the airpuff can reach the dentate-interpositus by either a direct route from the fifth sensory nuclei, or through the rostro-medial inferior olivary complex. Abbreviations are as follows: CBM Cortex - cerebellum cortex; CR - conditioned response; DCN - dorsal cochlear nucleus; D-I - dentate-interpositus nuclei; IC - inferior colliculus; icp - inferior cerebellar peduncle; 10 - inferior olivary complex; Lateral pons - lateral pontine nuclei; mcp - middle cerebellar peduncle; Nil - nuclei of the lateral lemniscus; RF - reticular formation or some nuclei thereof; SC - superior colliculus, scp - superior cerebellar peduncle; SO - superior olive; T - nucleus of the trapezoid body; UCR - unconditioned response pathway.

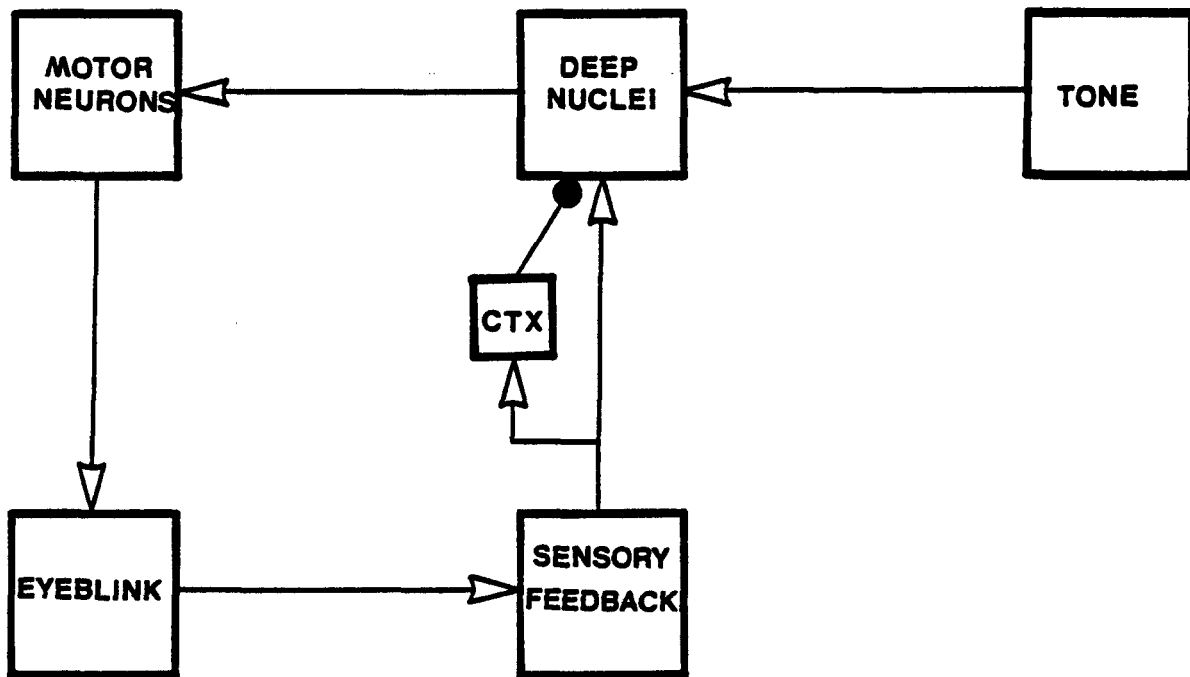

Figure 2 Hypothetical circuit illustrating how the cerebellar nuclei are ideally situated to compare actual ongoing production of the learned response with intentional movement of the learned response. This circuitry is based upon the fact that my experiments have shown that the cerebellar dentate-interpositus nuclei are involved in the production of the learned eyeblink response. Furthermore, anatomical and electrophysiological experiments have shown that the dentate-interpositus nuclei and cerebellar cortex (aniform) receive direct somatosensory inputs concerning the face.

### General conclusions

The involvement of the cerebellum in the learning and retention of the motor responses was surveyed over a number of learning tasks from relatively simple (classical conditioning) to relatively complex (maze learning). Although it is often suggested that the cerebellum is involved in the preprogramming of complex learned movements, the best evidence for an involvement of the cerebellum in learned movements is within simple paradigms (e.g. classical conditioning, VOR) or within simple, constituent parts of more complex movements (e.g. onset, offset of musculature contraction). Furthermore, the cerebellar deep nuclei, and not the cerebellar cortex, appear to be most critically involved in the production of learned movements. However, the flocculus, which does not connect mainly with structures other than the cerebellar deep nuclei, appears to be involved in the plasticity of eye movement responses (VOR and recovery of function after hemilabyrinthectomy).

In conclusion, the present evidence appears to indicate that a major role of the cerebellum is to act as a short latency low level computer which concerns itself with the parts of movements requiring a quick feedback or feedforward. The cerebellum seems ideally situated to utilize both inputs from the periphery concerning the ongoing production of the movement, and from the

cerebral cortex and brainstem, perhaps representing the planning of future movements.

Classical conditioning is one paradigm in which the cerebellar deep nuclei are essentially involved in the learning and production of the response. Therefore this learning situation represents a paradigm in which the proper functioning and neural integration within the cerebellum may be studied with, hopefully, very fruitful results.

INDEX TO REFERENCES ~ ACCORDING TO TOPIC SEE ALSO REFERENCES AT  
END OF EACH CHAPTER

CEREBELLUM

Afferents

15,17,25,26,29,45,79,112,114,120,133,138,146,158,262,302,306 (see  
also inferior olive)

Anatomy

27,48,50,75,155

Cerebral cortex

78

Cortico-nuclear projection

28,62,63,95,96,134

Cortex lesions

147,176,177,245,246,308,309

Efferents

26,60

Inferior Olive

5,8,11,13,31,32,33,56,64,73,88,102,103,104,113,115,123,127,129,  
130,148,159,176,177,259,266,298,299

Lesions Arm/Wrist Movements

9,37,38,43,55,116,117,118,164,165,201,207,247,248,259,286,289

Classical Conditioning - Conditioned Avoidance

14,52,53,67,68,80,81,83,85,135,140,141,142,143,144,160,167,172,  
173,184,185,189,191,194,210,237,286,287,288,307

Complex tasks

39,167,210

General

6,147,216,226

vestibulo-ocular Reflex

107,122,130,131,227,244,249,267,268

Recordings

40,51,89,101,163,164,189,191,198,229,247,248,277,278,279,280,281,  
282,286,287,288

Stimulation

35,80,185,232,233,243,253.

Teleceptive Afferents

17,44,79,84,119,120,133,136,138,146,214,215,254,255,258,262,302,  
306

Theory

1,3,18,19,20,24,66,74,76,77,90,121,124,126,156,186,303

Brainstem lesions

67,68,70,86,170,194

Classical conditioning

65,69,98,190,251,252

Deafferentation

153,154,175,260,265,270,271,272,273,274,276

Facial nucleus

59,162,269

Hippocampus

12,284,285

Learning models

22,23

Molecular studies of learning

21,42,108,139

NM efferents

46,47,99,100,105,238

Pyramidotomy

10,41,109,110

Red Nucleus

61,209,217,228,229,257,269,290

Superior Colliculus-

97,145,264

Telencephalic lesions

36,92,171,178,200,211,219,220,221,222,223,224,230,235,236,250,261

Vestibuloocular reflex

16,30,54,57,58,72,87,93,94,107,122,125,128,131,132,174,179,180,18

1,182,183,202,203,204,205,206,208,218,227,240,241,244,249,256

## References

- 1 Albus, J.S. A theory of cerebellar function. Math. Biosci. 10 (1971) 25-61.
- 2 Alley, K.A., Baker, R.G., and Simpson, J.I. Afferents to the vestibulocerebellum and the origin of the visual climbing fibers in the rabbit. Brain Res. 98 (1975) 585-589.
- 3 Andersen, P. Cerebellar synaptic plasticity- putting theories to the test. Trends in Neurosciences (1982) 324-325.
- 4 Anguete, P., and Brodal, A. The projection of the "vestibulocerebellum" onto the vestibular nuclei in the cat. Arch. Ital. Biol. 105 (1967) 441-479.
- 5 Armstrong, D.M., Harvey, R.J., and Schild, R.F. Topographical localization in the olivo-cerebellar projection: An electrophysiological study in the cat. J. Comp. Neurol. 154 (1974) 287-302.
- 6 Atkin, A., and Kozlovskaya, I.R. Effects of cooling cerebellar nuclei on evoked forearm oscillations. Exp. Neur. 50 (1976) 766-776.
- 7 Baranyi, A., and Feher, O. Conditioned changes of synaptic transmission in the motor cortex of the cat. Exp. Brain Res. 33 (1978) 283-298.
- 8 Bardin, J.M., Batini, C, Billard, J.M., Buisseret-Delmas, C, Conrath-Verrier, M., and Corvaja, N. Cerebellar output regulation by the climbing and mossy fibers with and without the inferior olive. J. Comp. Neurol. 213 (1983) 464-477.
- 9 Beaubaton, D., and Trouche, E. Participation of the cerebellar dentate nucleus in the control of a goal-directed movement in monkeys. Effects of reversible cooling or permanent dentate lesion on duration and accuracy of a pointing response. Exp. Brain Res. 46 (1982) 127-138.
- 10 Beck, C.H., and Chambers, W.W. Speed, accuracy, and strength of forelimb movement after unilateral pyramidotomy in Rhesus monkeys. J. Comp. Physiol. Psych. 70 (1970) 1-22.
- 11 Beitz, A.J. The topographical organization of the olivo-dentate and dentato-olivary pathways in the cat. Brain Res. 115 (1976) 311-317.
- 12 Berger, T.W. and Thompson, R.F. Neuronal Plasticity in the limbic system during classical conditioning of the rabbit nictitating membrane response. I. The hippocampus. Brain Res. 145 (1978) 323-346.



- 13 Berkeley, K.J. and Hand, P.J. Projections to the inferior olive of the cat. II. Comparisons of input from the gracile, cuneate and spinal trigeminal nuclei. J. Comp. Neurol. 180 (1978) 253-264.
- 14 Bianki, V.L. Conditioned reflexes to light and sound in fishes deprived of the cerebellum. Zh. vyssh. nerv. Deyat. Pavlova. 12 (1962) 962-968.
- 15 Bloedel, J.R. Cerebellar afferent systems: A review. Prog. Neurobiol. 2 (1973) 1-68.
- 16 Bossom, J., and Ommaya, A.K. Visuomotor adaptation (to prismatic transformation of retinal image) in monkeys with bilateral dorsal rhizotomy. Brain 91 (1968) 161-162.
- 17 Bower, J.M., Beerman, D.H., Gibson, J.M., Shambes, G.M., and Welker, W. Principles of organization of a cerebro-cerebellar circuit. Micromapping the projections from cerebral(S1) to cerebellar (granule cell layer) tactile areas of rats. Brain Behav. Evolution 18 (1981) 1-18.
- 18 Braitenberg, V. Functional interpretation of cerebellar histology. Nature 190 (1961) 539-540.
- 19 Braitenberg, V. Is the cerebellar cortex a biological clock in the millisecond range? Prog. Brain Res. 25 (1967) 334-346.
- 20 Braitenberg, V., and Onesto, N. The cerebellar cortex as a timing organ. Discussion of an hypothesis. Proc. 1st Int. Conf. Med. Cybernet. Naples, Giannini. (1962) 1-19.
- 21 Brandon, J.G., and Coss, R.G. Rapid dendritic spine stem shortening during one-trial learning: The Honeybee's first orientation flight. Brain Res. 252 (1982) 51-61.
- 22 Brindley, G.S. The classification of modifiable synapses and their uses in models for conditioning. Proc. Roy. Soc. Lond. 168 (1967) 361-376.
- 23 Brindley, G.S. Nerve net models of plausible size that perform many simple learning tasks. Proc. Roy. Soc. Lond. 174 (1969) 173-191.
- 24 Brindley, G.S. The use made by the cerebellum of the information that it receives from sense organs. Int. Brain Res. Org. Bull. 3 (1964) 80.
- 25 Brodal, A. and Jansen, J. The ponto-cerebellar projection in the rabbit and cat. Experimental investigations. J. Comp. Neurol. 84 (1946) 31-118.
- 26 Brodal, A. Neurological anatomy in relation to clinical medicine. (Oxford University Press, Oxford) (1981) pp. 294-393.
- 27 Brodal, A. The cerebellum of the rabbit. A topographical atlas of the folia as revealed in transverse sections. J. Comp. Neurol. 72 (1940) 63-81.
- 28 Brodal, A. Courville, J. Cerebellar corticonuclear

- projection in the cat. Crus II. An experimental study with silver methods. Brain Res. 50 (1973) 1-23.
- 29 Brodal, P. The projection from the nucleus reticularis tegmenti pontis to the cerebellum in the resus monkey. Exp. Brain Res. 38 (1980) 29-36.
- 30 Brodal, A., and Hoivak, B. Site and mode of termination of primary vestibulocerebellar fibers in the cat. Arch. Ital. Biol. 102 (1964) 1-21.
- 31 Brodal, A. and Walberg, F. The olivocerebellar projection in the cat studied with the method of retrograd axonal transport of horseradish peroxidase. IV. The projection to the anterior lobe. J. Comp. Neurol. 172 (1977) 85-108.
- 32 Brodal, A. and Walberg, F. The olivocerebellar projection in the cat studied with the method of retrograde axonal transport of horseradish peroxidase. VI. The projection onto longitudinal zones of the paramedian lobule. J. Comp. Neurol. 176 (1977) 281-294.
- 33 Brodal, A., Walberg, F., and Hoddevik, G. H. The olivocerebellar projection in the cat studied with the method of retrograde axonal transport of horseradish peroxidase. J. Comp. Neurol. 164 (1975) 449-470.
- 34 Brodal, A. Experimentelle untersuchungen uber die olivocerebellare lokalisation. Zeit. Ges. Neurol. 169 (1940) 1-153.
- 35 Brogden, W.J., and Gantt, W.H. Intraneural conditioning: cerebellar conditioned reflexes. Arch. Neurol. Psychiat. 48 (1942) 437-455.
- 36 Bromiley, R.B. Conditioned responses in a dog after removal of neocortex. J. comp. Physiol. Psych. 41 (1948) 102-110.
- 37 Brooks, V.B., Kozlovskaya, I.B., Atkin, A., Horvath, F.E., and Uno, M. Effects of cooling dentate nucleus on tracking-task performance in monkeys. J. Neurophysiol. 36 (1973) 974-995.
- 38 Brooks, V.B. Control of intended limb movements by the lateral and intermediate cerebellum. In Integration in the nervous system Lloyd, D.P.C. and Wilson, V.D. (Eds.) Igaku-Shoin Ltd. Tokyo-New York. (1979) 321-356.
- 39 Buchtel, H.A. Visual-learning deficits following cerebellar damage in rats. J. comp. Physiol. Psych. 72 (1970) 296-305.
- 40 Burton, J.E., and Onoda, N. Interpositus neuron discharge in relation to a voluntary movement. Brain Res. 121 (1977) 167-172.
- 41 Butz, P. Kaufmann, W., and Wiesendanger, M. Analyse einer ras-chen Willkurbeweguny bei parkinsonpatienten vor und nach stereo-taktischem Eingriff am Thalamus. Zeit. Neurol. 198 (1970) 105-119.

- 42 Carew, T.J., Hawkins, R.D., and Kandel, E.R. Differential classical conditioning of a defensive withdrawal reflex in Aplysia California. Science 219 (1982) 397-399.
- 43 Carpenter, M.B., Fabrega, H., and Glimsman, W. Physiological deficits occurring with lesions of labyrinth and fastigial nuclei. J. Neurophysiol. 22 (1959) 222-234.
- 44 Carpenter, M.B., Stein, B.M., and Peter, P. Primary vestibulocerebellar fibers in the monkey: distribution of fibers arising from distinctive cell groups of the vestibular ganglia. Amer. J. Anat. 135 (1972) 221-250.
- 45 Carpenter, M.B., and Hanna, G.R. Fiber projections from the spinal trigeminal nucleus in the cat. J. Comp. Neurol. 117 (1961) 117-131.
- 46 Cegavske, C.F., Thompson, R.F., Patterson, M.M., and Gormezano, I. Mechanisms of efferent neuronal control of the reflex nictitating membrane response in the rabbit (Oryctolagus cuniculus). J. Comp. Phys. Psych. 90 (1976) 411-423.
- 47 Cegavske, C.F., Patterson, M.M. and Thompson, R.F. Neuronal activity in the abducens nucleus during classical conditioning of the nictitating membrane response in the rabbit, Oryctolagus cuniculus. J. Comp. Phys. Psych. 93 (1979) 595-609.
- 48 Chambers, W.W., and Sprague, J.M. Functional localization in the cerebellum. II. Somatotopic organization in the cortex and nuclei. Arch. Neurol. Psychiat. 74 (1955) 653-680.
- 49 Chambers, W.W., and Sprague, J.M. Functional localization in the cerebellum. I. Organization in longitudinal cortico-nuclear zones and their contribution to the control of posture, both extrapyramidal and pyramidal. J. Comp. Neurol. 103 (1955) 105-130.
- 50 Chan-Palay, V. Cerebellar dentate nucleus. Organization, Cytology and transmitters. Springer-Verlag, New York. (1977)
- 51 Chapman, C.E., Spidalieri, G., and Lamarre, Y. A study of sensorimotor properties of dentate neurons during conditioned arm movements in the monkey. Soc. Neuroscience Abstr. 8 (1982) 830.
- 52 Clark, G.A., McCormick, D.A., Lavond, D.G., Baxter, K., Gray, W.J., and Thompson, R.F. Effects of electrolytic lesions of cerebellar nuclei on conditioned behavioral and hippocampal neuronal responses. Soc. Neuroscience Abstr. 8 (1982) 22.
- 53 Clark, G.A., McCormick, D.A., Lavond, D.G., and Thompson, R.F. Effects of lesions of cerebellar nuclei on conditioned behavioral and hippocampal neuronal responses. Submitted

- (1983).
- 54 Cohen, B. The vestibulo-ocular reflex arc. In Handbook of Sensory Physiology. Pt. 1: Vestibular System, ed. H.H. Kornhuber, New York: Springer-Verlag 6 (1974) 447-540.
- 55 Conrad, B., and Brooks, V<sup>B</sup>. Effects of dentate cooling on rapid arm movements. J. Neurophysiol. 37 (1974) 792-804.
- 56 Cook, J.R. and Wiesendanger, M. Input from trigeminal cutaneous afferents to neurones of the inferior olive in rats. Exp. Brain Res. 26 (1976) 193-202.
- 57 Courjon, J.H., Jeannerod, M., Ossuzio, I. and Schmid, R. The role of vision in compensation of vestibuloocular reflex after hemilabyrinthectomy in the cat. Exp. Brain Res. 28 (1977) 235-248.
- 58 Courjon, J.H., Flandrin, J.M., Jeannerod, M., and Schmid, R. The role of the flocculus in vestibular compensation after hemilabyrinthectomy. Brain Res. 239 (1982) 251-257.
- 59 Courville, J. The nucleus of the facial *nervei* the relation between cellular groups and peripheral branches of the *nerve*. Brain Res. 1 (1966) 338-354.
- 60 Courville, J. Somatotopical organization of the projection from the nucleus interpositus anterior of the cerebellum to the red nucleus. An experimental study in the cat with silver impregnation methods. Exp. Brain Res. 2 (1966) 191-215.
- 61 Courville, J. Rubrobulbar fibers to the facial nucleus and the lateral reticular nucleus (nucleus of the lateral funiculus). An experimental study in the cat with silver impregnation methods. Brain Res. 1 (1966) 317-337.
- 62 Courville, J., and Diakiw, N. Cerebellar corticonuclear projection in the cat. The vermis of the anterior and posterior lobes. Brain Res. 110 (1976) 1-20.
- 63 Courville, J., Diakiw, N., and Brodal, A. Cerebellar corticonuclear projection in the cat. The paramedian lobule. An experimental study with silver methods. Brain Res. 50 (1973) 25-45.
- 64 Courville, J., Augustine, J.R., and Martel, P. Projections from the inferior olive to the cerebellar nuclei in the cat demonstrated by retrograde transport of Horseradish Peroxidase. Brain Res. 130 (1977) 405-419.
- 65 Deaux, E.B. and Gormezano, I. Eyeball retraction: Classical conditioning and extinction in the albino rabbit. Science 141 (1963) 630-631.
- 66 Denny-Brown, D. The Cerebral Control of Movements, Liverpool University Press, Liverpool, England (1966).
- 67 Desmond, J.E., Berthier, N.E., and Moore, J.W. Brainstem elements essential for classically conditioned nictitating

- membrane response of the rabbit. Soc. Neurosci. Abstr.  
7 (1981) 651.
- 68 Desmond, J.E. and Moore, J.W. A brain stem region essential for classically conditioned but not unconditioned nictitating membrane response. Physiol. Behav. 28 (1982) 1029-1033.
- 69 Disterhoft, J.F., Kwan, H.H., and Lo, W.D. Nictitating membrane conditioning to tone in the immobilized albino rabbit. Brain Res. 137 (1977) 127-143. ""\*
- 70 Doty, R.W., Beck, E.C., and Kooi, K.A. Effect of brain-stem lesions on conditioned responses of cats. Exp. Neurology 1 (1959) 360-385.
- 71 Dow, R.S. Fiber connections of the posterior parts of the cerebellum in the cat and rat. J. Comp. Neurol. 63 (1936) 527-548.
- 72 Dufosse, M., Ito, M., Jastreboff, P.J., and Miyashita, Y. A neuronal correlate in rabbit's cerebellum to adaptive modification of the vestibulo-ocular reflex. Brain Res. 150 (1978) 611-616.
- 73 Dufosse, M., Ito, M., and Miyashita, Y. Diminution and reversal of eye movements induced by local stimulation of rabbit cerebellar flocculus after partial destruction of the inferior olive. Exp. Brain Res. 33 (1978) 139-141.
- 74 Eccles, J.C. An instruction-selection theory of learning in the cerebellar cortex. Brain Res. 127 (1977) 327-352.
- 75 Eccles, J.C, Ito, M., and Szentagothai, J. The cerebellum as a neuronal machine. Heidelberg: Springer-Verlag New York (1967).
- 76 Eccles, J.C. The cerebellum as a computer: Patterns in space and time. J. Physiol. 229 (1978) 1-32.
- 77 Eccles, J.C, Sabah, N.H., Schmidt, R.F., and Taborikova, H. Mode of operation of the cerebellum in the dynamic loop control of movement. Brain Res. 40 (1972) 73-80.
- 78 Evarts, E.V. and Thach, W.T. Motor mechanisms of the CNS: Cerebrocerebellar interrelations. Ann. Rev. Physiol. 31 (1969) 451-497.
- 79 Fadiga, E., and Pupil!i, G.C Teleceptive components of the cerebellar function. Physiol. Rev. 44 (1964) 432-486.
- 80 Fanardjian, V.V., and Papoyan, E.V. Electrophysiological analysis of conditioned reflexes where the conditional stimulus is the stimulation of phylogenetically different parts of the cerebellum. Brain Behav. Evol. 9 (1974) 458-487.
- 81 Fanardjian, V.V. Influence of the cerebellum ablation on motor conditioned reflexes in dogs. Zg. vyssh. nerv. Deyat. I.P. Pavlova 11 (1961) 920-926.
- 82 Fanardjian, V.V., and Papoyan, E.V. On the peculiarities of

- effector generalization and specialization of the dog motor conditioned reflexes. Fiziol. Zh. SSSR 46 (1960) 1447-1455.
- 83 Fish, B.S., Baisden, R.H., and Woodruff, M.L. Cerebellar nuclear lesions in rats: Subsequent avoidance behavior and ascending anatomical connections. Brain Res. 166 (1979) 27-38.
- 84 Freeman, J.A. Responses of cat cerebellar purkinje cells to convergent inputs from cerebral cortex and peripheral sensory systems. J. Neurophysiol. 33 (1970) 697-712.
- 85 Gambaryan, L.S. Conditioned avoidance reflexes induced in dogs with cerebellar lesions. Physiologia bohemoslow 9 (1960) 261-266,
- 86 Gastaut, H. The role of the reticular formation in establishing conditioned reactions. In: Reticular formation of the brain. Jasper, (Ed.) 561-577.
- 87 Gauthier, G.M., and Robinson, D.A. Adaptation of the human vestibuloocular reflex to magnifying lenses. Brain Res. 92 (1975) 331-35.
- 88 Gellman, R., Houk, J.C., and Gibson, A.R. Somatosensory properties of the inferior olive of the cat. In press (1983).
- 89 Gilbert, P.F.C, and Thach, W.T. Purkinje cell activity during motor learning. Brain Res. 128 (1977) 309-328.
- 90 Gilbert, P.F.C. A theory of memory that explains the function and structure of the cerebellum. Brain Res. 70 (1974) 1-18.
- 91 Gil man, S. The nature of cerebellar dyssynergia. In Modern Trends in Neurology, ed. D. Williams. Butterworth, London TT97D7.
- 92 Girden, E., Mettler, F.A., Finch, G., and Culler, E. Conditioned responses in a decorticate dog to acoustic, thermal, and tactile stimulation. J. comp. Psychol. 21 (1936) 367-385.
- 93 Gonshor, A., and Melvill Jones, G. Plasticity of the adult human vestibulo-ocular reflex arc. Proc. Can. Fed. Proc. Biol. Soc. 14 (1971) 11.
- 94 Gonshor, A., and Melvill Jones, G. Extreme vestibulo-ocular adaptation induced by prolonged optical reversal of vision. J. Physiol. London 256 (1976) 381-414.
- 95 Goodman, D.C., Hallet, R.E., Welch, R.B. Cerebellar corticonuclear pathways in the albino rat. Anat. Rec. 136 (1960) 199.
- 96 Goodman, D.C., Hallet, R.E., Welch, R.B. Patterns of localization in the cerebellar cortico-nuclear projections of the albino rat. J. Comp. Neurol. 121 (1963) 51-67.
- 97 Gordon, B. Superior colliculus: structure, physiology, and

- possible functions. MTP Int. Rev. Sci. 3 (1975) 185-230.
- 98 Gormezano, I., Schneiderman, N., Deaux, E., and Fuentes, I. Nictitating membrane: Classical conditioning and extinction in the albino rabbit. Science 138 (1962) 33-34.
- 99 Grant, K. Gueritaud, J.P., HorchoTie-Bossavit, G., and Tyc-Dumont, S. Anatomical and electrophysiological identification of the motoneurons supplying the cat retractor bulbi muscle. Expl. Brain Res. 34 (1979) 541-550.
- 100 Gray, T.S., McMaster, S.E., Harvey, J.A., and Gormezano, I. Localization of retractor bulbi motoneurons in the rabbit. Brain Res. 226 (1981) 93-106.
- 101 Grimm, R.J., Rushmer, D.S. The activity of dentate neurons during an arm movement sequence. Brain Res. 71 (1974) 309-326.
- 102 Groenewegen, H.J., Voogd, J., and Freedman, S.L. The parasagittal zonation within the olivocerebellar projection. I. Climbing fiber distribution in the intermediate and hemispheric parts of cat cerebellum. J. Comp. Neurol. 183 (1979) 551-602.
- 103 Haddad, G.H., Demer, J.L., and Robinson, D.A. The effect of lesions of the dorsal cap of the inferior olive on the vestibulo-ocular and optokinetic systems of the cat. Brain Res. 185 (1980) 265-275.
- 104 Haroian, A.J. Cerebello-olivary projections in the rat: an audioradiographic study. Brain Res. 235 (1982) 125-130.
- 105 Harrison, T.A. Cegavske, C.F. and Thompson, R.F. Neural activity recorded in the abducens and oculomotor nuclei during nictitating membrane conditioning in the rabbit. Soc. Neuroscience Abstr. 4 (1978) 259.
- 106 Harvey, J.A. and Gormezano, I. Drug effects of classical conditioning of the rabbit nictitating membrane response. Soc. Neuroscience Abstr. 7 (1981) 359.
- 107 Hassul, M., Daniels, P.D., and Kimm, J. Effects of bilateral f 1 occulectomy on the vestibulo-ocular reflex in the chinchilla. Brain Res. 118 (1976) 339-343.
- 108 Hawkins, R.D., Abrams, T.W., Carew, T.J., and Kandel, E.R. A cellular mechanism of classical conditioning in Aplysia: Activity-dependent amplification of presynaptic facilitation. Science 219 (1982) 400-402.
- 109 Hepp-Reymond, M.C., Wiesendanger, M. Unilateral pyramidotomy in monkeys: Effect on force and speed of a conditioned precision grip. Brain Res. 36 (1972) 117-131.
- 110 Hepp-Reymond, M.C., Trouche, E., and Wiesendanger, M. Effects of unilateral and bilateral pyramidotomy on a conditioned rapid precision grip in monkeys (Macaca

- fascicularis). Exp. Brain Res. 21 (1974) 519-527.
- 111 Hiraoka, M., and Shimamura, M. Neural mechanisms of the corneal blinking reflex in cats. Brain Res. 125 (1977) 265-275.
- 112 Hoddevik, G.H. The projection from nucleus reticularis tegmenti pontis onto the cerebellum in the cat. A study using the methods of anterograde degeneration and retrograde axonal transport of horseradish peroxidase. Anat. Embryo! 153 (1978) 227-242.
- 113 Hoddevik, G.H., Brodal, A., and Walberg, F. The olivocerebellar projection in the cat studied with the method of retrograde axonal transport of horseradish peroxidase. III. The projection to the vermal visual area. J. Comp. Neur. 169 (1976) 155-170.
- 114 Hoddevik, G.H., Brodal, A., Kawamura, K., and Hashikawa, T. The pontine projection to the cerebellar vermal visual area studied by means of the retrograde axonal transport of horseradish peroxidase. Brain Res. 123 (1977) 209-227.
- 115 Hoddevik, G.H., and Brodal, A. The olivocerebellar projection studied with the method of retrograde axonal transport of horseradish peroxidase. II. The projections to the flocculonodular lobe and the paraflocculus in the rabbit. J. Comp. Neurol. 176 (1977) 269-280.
- 116 Holmes, G. The symptoms of acute cerebellar injuries due to gunshot injuries. Brain 40 (1917) 461-535.
- 117 Holmes, G. Clinical symptoms of cerebellar disease and their interpretation. Lancet (1922).
- 118 Horvath, F.E., Atkin, A., Kozlovskaya, I., Fuller, D.R.G., and Brooks, V.B. Effects of cooling the dentate nucleus on alternating bar-pressing performance in monkey. Int. J. Neurol. 7 (1968) 252-270.
- 119 Huang, C, Liu, G., and Huang, R. Projections from the cochlear nucleus to the cerebellum. Brain Res. 244 (1982) 1-8.
- 120 Ikeda, M. Projections from the spinal and the principle sensory nuclei of the trigeminal nerve to the cerebellar cortex in the cat, as studied by retrograde transport of horseradish peroxidase. J. comp. Neurol. 184 (1979) 567-586.
- 121 Ito, M. Neurophysiological aspects of the cerebellar motor control system. Int. J. Neurol. 7 (1970) 162-176.
- 122 Ito, M., Shiida, T., Yagi, N., and Yamamoto, M. Visual influence on rabbit horizontal vestibulo-ocular reflex presumably effected via the cerebellar flocculus. Brain Res. 65 (1974) 170-174.
- 123 Ito, M., Orlov, I., and Shimoyama, I. Reduction of the cerebellar stimulus effects on rat dieters neurons after



- chemical destruction of the inferior olive. Exp. Brain Res. 33 (1978) 143-145.
- 124 Ito, M. Neural design of the cerebellar motor control system. Brain Res. 40 (1972) 81-84.
- 125 Ito, M. Cerebellar control of the vestibulo-ocular reflex-around the flocculus hypothesis. Ann. Rev. Neurosci. 5 (1982) 275-296.
- 126 Ito, M. The control mechanisms of cerebellar motor system. In The Neurosciences Third Study Program, F.O. Schmitt and F.6. Worden (eds.) Boston: MIT Press (1974) 293-303.
- 127 Ito, M., and Miyashita, Y. The effects of chronic destruction of inferior olive upon visual modification of the horizontal vestibuloocular reflex of rabbits. Proc Jap. Acad. 51 (1975) 716-760.
- 128 Ito, M., Nisimaru, N., and Yamamoto, M. Specific patterns of neuronal connexions involved in the control of the rabbit's vestibulo-ocular reflex by the cerebellar flocculus. J. Physiol. 265 (1977) 833-854.
- 129 Ito, M., Nisimaru, N., and Shibuki, K. Destruction of inferior olive induces rapid depression in synaptic action of cerebellar Purkinje cells. Nature 277 (1979) 568-569.
- 130 Ito, M., Jastreboff, P.J., and Miyashita, Y. Retrograde influence of surgical and chemical floccul ectomy upon dorsal cap neurons of the inferior olive. Neurosci. Lett. 20 (1980) 45-48.
- 131 Ito, M., Sakurai, M., and Togroach, P. Evidence for modifiability of parallel fiber-Purkinje cell synapses. In Advances in Physiological Sciences, Oxford: Permagon Press 2 (1981) 97-105.
- 132 Ito, M., Sakurai, M., andTongroach, P. Climbing fibre induced depression of both mossy fibre reponsiveness and glutamate sensitivity of cerebellarpurkine cells. J. Physiol. London 324 (1982) 113-134.
- 133 Jacquin, M.F., Semba, K., Rhoades, R.W., and Egger, M.D. Trigeminal primary afferents project bilaterally to dorsal horn and ipsilaterally to cerebellum, reticular formation, and cuneate, solitary, supratrigeminal and vagal nuclei. Brain Res. 246 (1982) 285-291.
- 134 Jansen, J. and Brodal, A. Experimental studies on the intrinsic fibers of the cerebellum. III. The cortical nuclear projection in the rabbit and monkey (Macacus Rhesus). Skr. Norske Vidensk.-Acad., I. Mat.-nat. Kl. 3 (1942) 1-50.
- 135 Javorskaja, K.J. Conditioned reflector activity of the cats following an ablation of the cerebellum. In: Probl. Srav. Fisiol. Nerv. Deyat. Acad. Med. Sci. USSR PresT,

- Leningrad (1958) 180-165.
- 136 Jen, P.H.S., Sun, X., and Kamada, T. Responses of cerebellar neurons of the CF-FM bat, Pteronotus pamellii to acoustic stimuli. Brain Res. 252 (1982) 167-171.
- 137 Jerge, C.R. Organization and function of the trigeminal mesencephalic nucleus. J. Neurophysiol. 26 (1963) 379-392.
- 138 Joseph, J.W., Shambes, G.M., Gibson, J.M., and Welker, W. Tactile projections to granule cells in caudal vermis of the rat's cerebellum. Brain Behav. Evol. 15 (1978) 141-149.
- 139 Kandel, E. R., and Schwartz, J.H. Molecular biology of learning: Modulation of transmitter release. Science 218 (1982) 433-443.
- 140 Kaplan, H., and Aronson, L.R. Function of forebrain and cerebellum in learning in the teleost Tilapia Heudelotii Macrocephala. Bull. Amer. Museum Natural History 142 (1969) 142-208.
- 141 Karamian, A.I. Evolution of the functional interactions of cerebellum and cerebral hemispheres. I. On functional interactions of cerebellum and cerebral hemispheres in teleosts. Fiziol. Zh. SSSR. 35 (1949) 167-181.
- 142 Karamian, A.I. Evolution of the functional interactions of cerebellum and cerebral hemispheres. II. On functional interactions of cerebellum and cerebral hemispheres in amphibia. Fiziol. Zh. SSSR. 35 (1949) 653-667.
- 143 Karamian, A.I. Evolution of the function of the cerebellum and cerebral hemispheres. Washington: U.S. Dept. of Commerce. (Translated from Russian 1962) (1956).
- 144 Karamian, A.I., Fanardjian, V.V., and Kosareva, A.A. The functional and morphological evolution of the cerebellum and its role in behavior. In R. Llinas (Ed.) Neurobiology of cerebellar evolution and development, First international symposium. Chicago! American Medical Association, 1969.
- 145 Kassel, J. Superior colliculus projections to tactile areas of rat cerebellar hemispheres. Brain Res. 202 (1980) 291-305.
- 146 Kawamura, K. and Brodal, A. The tectopontine projection in the cat: An experimental anatomical study with comments on pathways for teleceptive impulses to the cerebellum. J. comp. Neurol. 149 (1973) 371-390.
- 147 Keller, A.D., Roy, R.S., and Chase, W.P. Extirpation of the neocerebellar cortex without eliciting so-called cerebellar signs. Am. J. Physiol. 118 (1937) 720-733.
- 148 Kennedy, P.R., Ross, H\*G., and Brooks, V.B. Participation of the principal olivary nucleus in neocerebellar motor control. Exp. Brain Res. 47 (1982) 95-104.
- 149 Kettner, R.N., Shannon, R.V., Nguyen, T.M. and Thompson, R.F. Simultaneous behavioral and neural (cochlear nucleus)

- measurement during signal detection in the rabbit. Perception and Psychophysics 28 (1980) 504-513.
- 150 Kettner, R.E. Unpublished doctoral thesis. University of California, Irvine (1981).
- 151 Kettner, R.E., and Thompson, R.F. Auditory signal detection and decision processes in the nervous system. J. Comp. Physiol. Psych. 96 (1982) 328-331.
- 152 Kim, E.H.J., Woody, CD., and Berthier, N.E. Rapid acquisition of conditioned eye blink responses in cats following pairing of an auditory CS with Glabella tap US and Hypothalamic stimulation. J. Neurophysiol. 49 (1983) 767-779.
- 153 Knapp, H.D., Taub, E., and Berman, A.J. Effect of deafferent-iation on a conditioned avoidance response. Science 128 (1958) 842-843.
- 154 Knapp, H.D., Taub, E., and Berman, A.J. Movements in monkeys with deafferented forelimbs. Exp. Neurol. 7 (1963) 305-315.
- 155 Korneliussen, H.K. On the morphology and subdivision of the cerebellar nuclei of the rat. J. Hirnforsch. 10 (1968) 109-122.
- 156 Kornhuber, H.H. Motor functions of the cerebellum and basal ganglia: the cerebello-cortical saccadic (ballistic) clock, the cerebello-nuclear hold regulator, and the basal ganglia ramp (voluntary) speed smooth movement generator. Kybernetik 8 (1971) 157-162.
- 157 Kornhuber, H.H. Cerebral cortex, cerebellum and basal ganglia: An introduction to their motor functions. In: The Neurosciences: Third Study Program (F.O. Schmitt and F.G. Worden, eds.) Cambridge, Mass. MIT Press. (1974) 267-280.
- 158 Kotchabhakdi, N. and Walberg, F. Cerebellar afferents from neurons in motor nuclei of cranial nerves demonstrated by retrograde axonal transport of horseradish peroxidase. Brain Res. 137 (1977) 158-163.
- 159 Kotchabhakdi, N., Walberg, F., and Brodal, A. The olivocerebellar projection in the cat studied with the method of retrograde axonal transport of horseradish peroxidase. VII. The projection to lobulus simplex, crus I and cms II. J. Comp. Neurol. 182 (1978) 293-314.
- 160 Krasusky, V.K. General nature of changes of food conditioned reflexes in dogs following a surgical lesion of the cerebellum. Zh. vyssh. nerv. Deyat. I.P. Pavlova 7 (1957) 733-740.
- 161 Kraus, N., and Disterhoft, J.F. Response plasticity of single neurons in rabbit auditory association cortex during tone-signalled learning. Brain Res. 246 (1982) 205-215.
- 162 Kume, M., Uemura, M., Matsuda, R., Matsushima, R. and Mizuno, N. Topographical representation of peripheral branches of

- peripheral branches of the facial nerve within the facial nucleus: A HRP study in the cat. Neurosci. Lett. 8 (1978) 5-8.
- 163 Lamarre, Y., Spiradieri, G., and C.E. Chapman. A comparison of neuronal discharge recorded in the sensori-motor cortex, parietal cortex and dentate nucleus of the monkey during arm movements triggered by light, sound or somesthetic stimuli. (1982) In press.
- 164 Lamarre, Y., Spidalieri, G., and Busby, L. Effects of dentate lesions on discharge patterns of motor cortex neurons and reaction time in monkeys. Soc. Neuroscience Abstr. 5 (1979) 375.
- 165 Lamarre, Y., and Jacks, B. Involvement of the cerebellum in the initiation of fast ballistic movement in the monkey. Electro-encephalogr. Clin. Neurophysiol. (suppl.) 34 (1978) 442-447.
- 166 Lashley, K.S. Brain Mechanisms and intelligence. University of Chicago Press, Chicago, 111. (1929).
- 167 Lashley, K.S., and McCarthy, D.A. The survival of the maze habit after cerebellar injuries. J. Comp. Psychol. 6 (1926) 423-433.
- 168 Lashley, K.S. Studies of cerebral function in learning. V. The retention of motor habits after destruction of the so-called motor areas in primates. Arch. Neurol. Psychiat. 12 (1924) 249-276.
- 169 Lashley, K.S. In search of the engram. In Symp. Soc. Exp. Biol. New York: Cambridge University Press, 4 (1950) 454-482.
- 170 Lavond, D.G., McCormick, D.A., Clark, G.A., Holmes, D.T. and Thompson, R.F. Effects of ipsilateral rostral pontine reticular lesions on retention of classically conditioned nictitating membrane and eyelid reponse. Physiol. Psych., 9 (1982) 335-339.
- 171 Lebedinskaia, S.I., and Rosenthal, J.S. Reactions of a dog after removal of the cerebral hemispheres. Brain 58 (1935) 412-419.
- 172 Lifshitz, N.N. Influence of the cerebellar ablation on conditioned reflexes in dogs. In: Trudy fiziol. Inst. Pavlova Acad. Sci., Moscow 2 (1947)  $W^{UT}$
- 173 Lincoln, J.S., McCormick, D.A., and Thompson, R.F. Ipsilateral cerebellar lesions prevent learning of the classically conditioned nictitating membrane/eyelid response. Brain Res. 242 (1982) 190-193.
- 174 Lisberger, S.G. Role of the cerebellum during motor learning in the vestibulo-ocular reflex. Different mechanisms in different species? Trends in Neuroscience 5 (1982) 437-441.

- 175 Liu, C.N., and Chambers, W.W. A study of cerebellar dyskinesia in the bilaterally deafferented forelimbs of the monkey (Macaca mulatta and Macaca speciosa). Acta. Neurobiol. Exp. 31 (1971) 263-289.
- 176 Llinas, R., Walton, K., and Hillman, D.E. Inferior olive: Its role in motor learning. Science 190 (1975) 1230-1231.
- 177 Llinas, R. and Walton, K. Place of the cerebellum in motor learning. In: Brain mechanisms in memory and learning: From the single neuron to man. Edited by M.A.B. Brazier. Raven Press, New York (1979) 17-36.
- 178 Lovick, T.A., and Zbrozyna, A.W. Classical conditioning of the corneal reflex in the chronic decerebrate rat. Brain Res. 89 (1975) 337-340.
- 179 Maekawa, K., and Simpson, J.I. Climbing fiber responses evoked in vestibulocerebellum of rabbit from visual system. J. Neuro-physiol. 36 (1973) 649-666.
- 180 Maekawa, K., and Takeda, T. Afferent pathways from the visual system to the cerebellar flocculus of the rabbit. In Control of Gaze by Brain Stem Neurons R.G. Baker and A. Berthoz (eds.) Amsterdam: Elsevier (1977) 187-195.
- 181 Maekawa, K. and Simpson, J.I. Climbing fiber activation of Purkinje cells in the flocculus by impulses transferred through the visual pathway. Brain Res. 39 (1972) 245-251.
- 182 Maekawa, K., and Takeda, T. Mossy fiber responses evoked in the cerebellar flocculus of rabbits by stimulation of the optic pathway. Brain Res. 98 (1975) 590-595.
- 183 Maekawa, K., and Kimura, M. Mossy fiber projections to the cerebellar flocculus from the extraocular muscle afferents. Brain Res. 191 (1980) 313-325.
- 184 Malyukova, I.V. Influence of the neocerebellar extirpation on situational conditioned reflexes in dogs. Zh. vyssh. nerv. Deyat. I.P. Pavlova 13 (1963) 1052-1058.
- 185 Malyukova, I.V. The effect of electrical stimulation and partial coagulation of the telencephalon or cerebellar valvula on food procuring conditioned reflexes in fishes. Zh. vyssh. nerv. Deyat. Pavlova. 14 (1964) 895-903.
- 186 Marr, D. A theory of cerebellar cortex. J. Physiol. (London) 202 (1969) 437-470.
- 187 Marsh, J.T., and Worden, F.G. Sound evoked frequency-following response in central auditory pathway. Laryngoscope (St. Louis) 78 (1968) 1149-1163.
- 188 Mauk, M.D., Warren, J.T., and Thompson, R.F. Selective, Naloxone reversible depression of learned behavioral and hippo-campal responses. Science 216 (1981) 434-436.
- 189 McCormick, D.A., Lavond, D.G., Clark, G.A., Kettner, R.E., Rising, C.E., and Thompson, R.F. The engram found? Role of the cerebellum in classical conditioning of nictitating

- membrane and eyelid response. Bull. Psychon. Soc. 18 (1981) 103-105.
- 190 McCormick, D.A., Lavond, D.G., and Thompson, R.F. Concomitant classical conditioning of the rabbit nictitating membrane and eyelid responses: Correlations and implications. Physiol. Behav. 28 (1982) 769-775.
- 191 McCormick, D.A., Clark, G.A., Lavond, D.G., and Thompson, R.F. Initial localization of the memory trace for a basic form of learning. Proc. Nat. Acad. Sci. 79 (1982) 2731-2735.
- 192 McCormick, D.A. Low cost oscilloscope histogram generator with memory. Physiol. Behav. 27 (1981) 1121-1125.
- 193 McCormick, D.A. and Thompson, R.F. Locus Coeruleus lesions and resistance to extinction of a classically conditioned response: Involvement of the neocortex and the hippocampus. Brain Res. 245 (1982) 239-250.
- 194 McCormick, D.A., Guyer, P.E., and Thompson, R.F. Superior cerebellar peduncle lesions selectively abolish the ipsilateral classically conditioned nictitating membrane/eyelid response of the rabbit. Brain Res. 244 (1982) 347-350.
- 195 McCormick, D.A. and Thompson, R.F. Delayed extinction of a classically conditioned response in the rabbit induced by locus coeruleus lesions: Involvement of the neocortex and the hippocampus. Soc. Neuroscience Abstr. 7 (1981) 649.
- 196 McCormick, D.A., Lavond, D.G., Donegan, N.H., and Thompson, R.F. Neuronal responses of the rabbit brainstem and cerebellum during performance of the classically conditioned nictitating membrane/ eyelid response. Soc. Neuroscience Abstr. 8 (1982) 315.
- 197 McCormick, D.A., Lavond, D.G., and Thompson, R.F. Neuronal responses of the rabbit brainstem during performance of the classically conditioned nictitating membrane/eye!id response. Brain Res. (1983) In press.
- 198 McCormick, D.A., and Thompson, R.F. Neuronal responses of the cerebellum during learning and performance of the classically conditioned nictitating membrane/eyelid response in the rabbit. In preparation (see this dissertation) (1983).
- 199 McCormick, D.A., and Thompson, R.F. Stereotaxic atlas of the rabbit cerebellum. Brain Res. Bull. (1983) In press.
- 200 Megirian, D., and Bures, J. Unilateral cortical spreading depression and conditioned eyeblink responses in the rabbit. Exp. Neurology 27 (1970) 34-45.
- 201 Meyer-Lohmann, J., Hore, J., and Brooks, V.B. Cerebellar participation in generation of prompt arm movements. J. Neurophysiol. 40(1977) 1038-1050.

- 202 Miles, F.A., and Lisberger, S.G. Plasticity in the vestibulo ocular reflex: A new hypothesis. Ann. Rev. Neurosci. 4 (1981) 273-299.
- 203 Miles, F.A., and Braitman, D.J. Long-term adaptive changes in primate vestibuloocular reflex. II. Electrophysiological observations on semicircular canal primary afferents. J. Neurophysiol. 43 (1980) 1426-1436.
- 204 Miles, F.A., Braitman, D.J., and Dow, B.M. Long-term adaptive changes in primate vestibuloocular reflex. IV. Electrophysiological observations in the flocculus of adapted monkeys. J. Neurophysiol. 43 (1980) 1477-1493.
- 205 Miles, F.A., and Eighmy, B.B. Long-term adaptive changes in primate vestibuloocular reflex. I. Behavioral observations. J. Neurophysiol. 43 (1980) 1406-1425.
- 206 Miles, F.A., and Fuller, J.H. Adaptive plasticity in the vestibulo-ocular reflex of the rhesus monkey. Brain Res. 80 (1974) 512-516.
- 207 Miller, A.D. and Brooks, V.B. Parallel pathways for movement initiation in monkeys. Exp. Brain Res. 45 (1982) 328-332.
- 208 Miyashita, Y., Ito, M., Jastreboff, P., Maekawa, K., and Nagao, S. Effect upon eye movements of rabbits induced by severance of mossy fiber visual pathway to the cerebellar flocculus. Brain Res. 198 (1980) 210-215.
- 209 Mizuno, N., Mochizuki, K., Akimoto, C, Matsushima, R., and Nakamura, Y. Rubrobulbar projections in the rabbit. A light and electron microscopic study. J. Comp. Neur. 147 (1973) 267-280.
- 210 Monjan, A.A., and Peters, M.H. Cerebellar lesions and task difficulty in pigeons. J. Comp. Physiol. Psychol. 72 (1970) 171-176.
- 211 Moore, J.W., Yeo, C.H., Oakley, D.A., and Russell, I.S. Conditioned inhibition of the nictitating membrane response in decorticate rabbits. Behav. Brain Res. 1 (1980) 397-409.
- 212 Moore, J.W., and Desmond, J.E. Latency of the nictitating membrane response to periocular electro-stimulation in unanesthetized rabbits. Physiol. Behav. 28 (1982) 1041-1046.
- 213 Morrell, F. Electrophysiological contributions to the neural basis of learning. Physiological Reviews 41 (1961) 443-494.
- 214 Mortimer, J.A. Cerebellar responses to teleceptive stimuli in alert monkeys. Brain Res. 83 (1975) 369-390.
- 215 Mortimer, J.A. Temporal sequence of cerebellar Purkinje and nuclear activity in relation to the acoustic startle response. Brain Res. 50 (1973) 457-462.

- 216 Munson, J.B., and Monjan, A.A. Cerebellar lesions and auditory thresholds in cat. Physiol. Behav. 2 (1967) 161-165.
- 217 Murakami, F., Katsumaru, H., Saito, K., and Tsukahara, N. A quantitative study of synaptic reorganization in red nucleus neurons after lesion of the nucleus interpositus of the cat: an electron microscopic study involving intracellular injection of horseradish peroxidase. Brain Res. 242 (1982) 41-53.
- 218 Nakao, S., Curthoys, I.S., and Markham, C.H. Eye movement related neurons in the cat pontine reticular formation: projection to the flocculus. Brain Res. 183 (1980) 291-299.
- 219 Norman, R.J., Villablanca, J.R., Brown, K.A., Schwafel, J.A., and Buchwald, J.S. Classical eyeblink conditioning in the bilaterally hemispherectomized cat. Exp. Neurology 44 (1974) 363-380.
- 220 Norman, R.J., Buchwald, J.S., and Villablanca, J.R. Classical conditioning with auditory discrimination of the eye blink in decerebrate cats. Science 196 (1977) 551-553.
- 221 Oakley, D.A. and Russell, I.S. Neocortical lesions and Pavlovian conditioning. Physiol. Behav. 8 (1972) 915-926.
- 222 Oakley, D.A. Instrumental learning in neodecorticate rabbits. Nature (New Biol.) 233 (1971) 185-187.
- 223 Oakley, D.A., and Russell, I.S. Mass action and Pavlovian conditioning. Psychon. Sci. 12 (1968) 91-92.
- 224 Oakley, D.A., and Russell, I.S. Differential and reversal conditioning in partially neodecorticate rabbits. Physiol. Behav. 13 (1974) 221-230.
- 225 Olds, J., Disterhoft, J.F., Segal, M., Kornblith, C.L., and Hirsh, R. Learning centers of rat brain mapped by measuring latencies of conditioned unit responses. J. Neurophysiol. 35 (1972) 202-219.
- 226 Optican, L.M. and Robinson, D.A. Cerebellar-dependent adaptive control of primate saccadic system. J. Neurophysiol. 44 (1980) 1058-1076.
- 227 Optican, L.M., Zee, D.S., Miles, F.A., and Lisberger, S.G. Oculomotor deficits in monkeys with floccular lesions. Soc. Neuroscience Abstr. 6 (1980) 474.
- 228 Otabe, S. and Courville, J. Rubrobulbar fibers to the facial nucleus and the lateral reticular nuclei in the monkey. An experimental study with silver methods. Proc. Can. Fed. Biol. Soc. 16(1973) 88
- 229 Otero, J.B. Comparison between red nucleus and precentral neurons during learned movements in the monkey. Brain Res. 101 (1976) 37-46.
- 230 Papsdorf, J.D., Longman, D., and Gormezano, I. Spreading depression: Effects of applying KCL to the dura of the



- rabbit on the conditioned nictitating membrane response. Psychonomic Science 2 (1965) 125-126.
- 231 Pal ay, S.L., and Chan-Pal ay, V. (Eds.) The Cerebellum. New Vistas. Exp. Brain Res. Supp. 6 1982.
- 232 Perciavalle, V., Santangelo, F., Sapienza, S., Savoca, F., and Urbano, A. Motor effects produced by microstimulation of brach-ium pontis in the cat. Brain Res. 126 (1977) 557-562.
- 233 Perciavalle, V., Santangelo, F., Sapienza, S., Serapide, M.F., and Urbano, A. Motor responses evoked by microstimulation of restiform body in the cat. Exp. Brain Res. 33 (1978) 241-255.
- 234 Peters, M., and Filter, P.M. Performance of a motor task after cerebellar cortical lesions in rats. Physiol. Behav. 11 (1973) 13-16.
- 235 Poltyrev, S.S. Verborgene associationen des grosshirns bei hunden. Z. Biol. 97 (1936) 306-307.
- 236 Poltyrev, S. S., and Zeliony, G. Grosshirnrinde und associationsfunktion. Z. Biol., 90 (1930) 157-160.
- 237 Popov, N.F. The role of the cerebellum in elaborating the motor conditioned reflexes. In: Higher nervous activity Com. Acad. Press, Moscow 1 (1929) 140-138;
- 238 Powell, G.M., Berthier, N.E. and Moore, J.W. Efferent neuronal control of the nictitating membrane response in the rabbit (Oryctogalus cuniculus): A reexamination. Physiol. Behav. 23
- 239 Powell, D.A., Lipkin, M., and Milligan, W.L. Concomitant changes in classically conditioned heart rate and corneoretinal potential discrimination in the rabbit (Oryctogalus cuniculus) Learn. Motiv. 5 (1974) 532-547.
- 240 Precht, W. Vestibular mechanisms. Ann. Rev. Neurosci. 2 (1979) 265-289. '
- 241 Precht, W. and Llinas, R. Functional organization of the vestibular afferents to the cerebellar cortex of frog and cat. Exp. Brain Res. 9 (1969) 30-52.
- 242 Pribram, K.H. The neurophysiology of remembering. Sci. Am. 220 (1969) 73-86.
- 243 Rispal-Padel, L, Cicirata, F., and Pons, C. Cerebellar nuclear topography of simple and synergistic movements in the alert baboon (Papio Papio). Exp. Brain Res. 47 (1982) 365-380.
- 244 Robinson, D.A. Adaptive gain control of vestibuloocular reflex by the cerebellum. J. Neurophysiol. 39 (1976) 954-969.
- 245 Rosen, I, and Scheid, P. Cerebellar surface cooling influencing evoked activity in cortex and in interpositus nucleus. Brain Res. 45 (1972) 580-584.
- 246 Rubia, F.J., Angermeier, W.F., Davis, H.N., and Watkins,

- G.M. The effects of unilateral and bilateral cortical ablations of the cerebellar hemisphere upon learning and retention of an instrumental light-dark discrimination task in adult cats. Pflugers Arch. 310 (1969) 101-108.
- 247 Sasaki, K., Gemba, H., and Hashimoto, S. Influences of cerebellar hemispherectomy upon cortical potentials preceding visually initiated hand movements in the monkey. Brain Res. 205 (1981) 425-430.
- 248 Sasaki, K., Gemba, H., and Mizuno, N. Cortical field potentials preceding visually initiated hand movements and cerebellar actions in the monkey. Exp. Brain Res. 46 (1982) 29-36.
- 249 Schairer, J.O., and Bennett, M.V.L. Cerebellectomy in goldfish prevents adaptive gain control of the VOR without affecting the optokinetic system. In Neuroscience Satellite Symposium on Vestibular Function and Morphology ed. T. Gualtierotti. New York: Springer-Verlag (IWj):
- 250 Schmaltz, L.W., and Theios, J. Acquisition and extinction of a classically conditioned response in hippocampectomized rabbits (Oryctolagus cuniculus) J. Comp. Phys. Psych. 79 (1972) 328-333!
- 251 Schneiderman, N., Fuentes, I. and Gormezano, I. Acquisition and extinction of the classically conditioned eyelid response in the albino rabbit. Science 136 (1962) 650-652.
- 252 Schneiderman, N., Smith, M.C., Smith, A.C., and Gormezano, I. Heart rate classical conditioning in the rabbit. Psychonomic Science 6 (1966) 241-242.
- 253 Schultz, W., Montgomery, E.B., Jr., and Marini, R. Proximal limb movements in response to microstimulation of primate dentate and interpositus nuclei mediated by brain-stem structures. Brain 102 (1979) 127-146.
- 254 Shambes, G.M., Gibson, J.M., and Welker, W. Fractured somatotopy in granule cell tactile areas of rat cerebellar hemispheres revealed by micromapping. Brain Behav. Evol. 15 (1978) 94-140.
- 255 Shambes, G.M., Beerman, D.H., and Welker, W. Multiple tactile areas in cerebellar cortex: another patchy cutaneous projection to granule cell columns in rats. Brain Res. 157 (1978) 123-128.
- 256 Shinoda, Y., and Yoshida, K. Neural pathways from the vestibular labyrinths to the flocculus in the cat. Exp. Brain Res. 22 (1975) 97-111.
- 257 Smith, A.M. The effects of rubral lesions and stimulation on conditioned forelimb flexion responses in the cat. Physiol. Behav. 5 (1970) 1121-1126.
- 258 Snider, R.S. and Stowell, A. Receiving areas of tactile,

- auditory, and visual systems in the cerebellum. J. Neurophysiol. 7 (1944) 331-357.
- 259 Soechting, J.F., Ranish, N.A., Palminteri, R., and Terzuolo, C.A. Changes in a motor pattern following cerebellar and olivary lesions in the squirrel monkey. Brain Res. 105 (1976) 21-44.
- 260 Soechting, J.F. Modeling of a simple motor task in man. Motor output dependence on sensory inputs. Kybernetik 14 (1973) 25-34.
- 261 Solomon, P.R. and Moore, J.W. Latent inhibition and stimulus generalization of the classically conditioned nictitating membrane response in rabbits (*Qryctolagus cuniculus*) following dorsal hippocampal ablation. J. Comp. Phys. Psych. 89 (1975) 1192-1203.
- 262 Somana, R., Kotchabhakdi, N., and Walberg, F. Cerebellar afferents from the trigeminal sensory nuclei in the cat. Exp. Brain Res. 38 (1980) 57-64.
- 263 Sprague, J.M. Interaction of cortex and superior colliculus in mediation of visually guided behavior in the cat. Science 153 (1966) 1544-1547.
- 264 Stein, B.E., Magalhaes-Castro, B. and Kruger, L. Relationship between visual and tactile representations in cat superior colliculus. J. Neurophysiol. 39 (1976) 401-419.
- 265 Stein, B.M., and Carpenter, M.W. Effects of dorsal rhizotomy upon subthalamic dyskinesia in the monkey. Arch. Neurol. 13 (1965) 567-583.
- 266 Swenson, R.S. and Castro, A.J. The afferent connections of the inferior olivary complex in rats. An anterograde study using autoradiographic and axonal degeneration techniques. Neuroscience 8 (1983) 259-275.
- 267 Takemori, S., and Cohen, B. Visual suppression of vestibular nystagmus in rhesus monkey. Brain Res. 72 (1974) 203-212.
- 268 Takemori, S., and Cohen, B. Loss of visual suppression of vestibular nystagmus after flocculus lesions. Brain Res. 72 (1980) 213-224.
- 269 Takeuchi, Y., Nakano, K., Uemura, M., Matsuda, K., Matsushima, R., and Mizuno, N. Mesencephalic and pontine afferent fiber system to the facial nucleus in the cat. A study using horseradish peroxidase and silver impregnation techniques. Exp. Neurol. 66 (1979) 330-342.
- 270 Taub, E., Bacon, R.C., and Berman, A.J. Acquisition of a trace-conditioned avoidance response after deafferentation of the responding limb. J. Comp. Physiol. Psychol. 59 (1965) 275-279.
- 271 Taub, E., and Berman, A.J. Avoidance conditioning in the

- absence of relevant proprioceptive and exteroceptive feedback. J. Comp. Physiol. Psychol. 56 (1963) 1012-1016.
- 272 Taub, E., and Berman, A.J. Movement and learning in the absences of sensory feedback, pp. 173-192. In The Neuropsychology of Spatially Oriented Behavior ed. S.J. Freeman. Dorsey Press, Homewood, Illinois.
- 273 Taub, E., Ellman, S.J., and Berman, A.J. Deafferentation in monkeys: Effect on conditioned grasp response. Science 151 (1966) 593-594.
- 274 Taub, E., Teodoru, D., Ellman, S.J., Bloom, R.F., and Berman, A.J. Deafferentation in monkeys: Extinction of avoidance responses, discrimination and discrimination reversal. Psychon. Sci. 4 (1966) 323-324.
- 275 Terzuolo, C.A., and Viviani, P. Parameters of motion and EMG activities during some simple motor tasks in normal subjects and cerebellar patients In I.S. Cooper, M. Riklan and R.S. Snider (Eds.) The Cerebellum, Epilepsy, and Behavior. Plenum Press, New York (1973).
- 276 Terzuolo, C.A., Soechting, J.F., and Ranish, N.A. Studies on the control of some simple motor tasks. V. Changes in motor output following dorsal root section in squirrel monkey. Brain Res. 70 (1974) 521-526.
- 277 Thach, W.T. Discharge of Purkinje and cerebellar nuclear neurons during rapidly alternating arm movements in the monkey. J. Neurophysiol. 31 (1968) 785-797.
- 278 Thach, W.T. Cerebellar output: Properties, synthesis and uses. Brain Res. 40 (1972) 89-97.
- 279 Thach, W.T. Discharge of cerebellar neurons related to two maintained postures and two prompt movements. I. Nuclear cell output. J. Neurophysiol. 33 (1970) 527-536.
- 280 Thach, W.T. Discharge of cerebellar neurons related to two maintained postures and two prompt movements. II. Purkinje cell output and input. J. Neurophysiol. 33 (1970) 537-547.
- 281 Thach, W.T. Timing of activity in cerebellar dentate nucleus and cerebral motor cortex during prompt volitional movement. Brain Res. 88 (1975) 233-241.
- 282 Thach, W.T. Correlation of neural discharge with pattern and force of muscular activity, joint position, and direction of intended next movement in motor cortex and cerebellum. J. Neurophysiol. 41(1978) 654-676.
- 283 Thompson, R. Localization of the "visual memory system" in the white rat. Physiol. Psych. Monograph 69 (1969) 1-29.
- 284 Thompson, R.F., Berger, T.W., Cegavske, C.F., Patterson, M.M., Roemer, R.A., Teyler, T.J., and Young, R.A. The search for the engram. Amer. Psychol. 31 (1976) 209-227.
- 285 Thompson, R.F., Berger, T.W., Berry, S.D., Hoehler^ F.K., Ket-tner, R.E. and Weiss, D.J. Hippocampal substrate of

- classical conditioning. Physiol. Psych. 8 (1980) 262-279.
- 286 Thompson, R.F., McConnick, D.A., Lavond, D.G., Clark, G.A., Ket-tner, R.E. and Mauk, M.D. The engram found? Initial localization of the memory trace for a basic form of associative learning. In A.N. Epstein (Ed.) Progress in Psychobiology and Physiological Psychology. New York: Academic Press, Inc. (1982).
- 287 Thompson, R.F., Barchas, J.D., Clark, D.A., Donegan, N., Ket-tner, R.E., Lavond, D.G., Madden, J., Mauk, M.D., and McCormick, D.A. Neuronal substrates of associative learning in the mammalian brain. In Alkan, D.L. and Farley, J. (Eds.), Primary neural substrates of learning and behavioral change. Princeton, NJ: Princeton University Press (1983) In press.
- 288 Thompson, R.F., Berger, T.W., and Madden, J., IV. Cellular processes of learning and memory in the mammalian CNS. Annual Review of Neuroscience. (1983).
- 289 Trouche, E, and Beaubaton, D. Initiation of a goal-directed movement in the monkey. Role of the cerebellar dentate nucleus. Exp. Brain Res. 40 (1980) 311-321.
- 290 Tsukahara, N., Oda, Y., and Notsu, T. Classical conditioning mediated by the red nucleus in the cat. J. Neuroscience 1 (1981) 72-79.
- 291 Tsukahara, N. Synaptic plasticity in the mammalian central nervous system. Ann. Rev. Neurosci. 4 (1981) 351-379.
- 292 Turner, R.S., and German, W.J. Functional anatomy of brachium pontis. (1940).
- 293 Uno, M., Kozlovskaya, I.B., and Brooks, V.B. Effects of cooling interposed nuclei on tracking-task performance in monkeys. J. Neurophysiol. 36 (1973) 996-1003.
- 294 Viviani, P., and Terzuolo, C.A. Modeling of simple motor task in man. Intentional arrest of an ongoing movement. Kybetetik 14 (1973) 35-62.
- 295 Voogd, J. The cerebellum of the cat; Structure and fibre connections. Van Gorcum and Co., Assen. (1964).
- 296 Voogd, J. Comparative aspects of the structure and fibre connections of the mammalian cerebellum. In: Progress in Brain Research Fox, C.A., and Snider, R.S. (eds.) Amsterdam: Elsevier. 25 (1967) 94-134.
- 297 Voogd, J. The importance of fibre connections in the comparative anatomy of the mammalian cerebellum. In: Neurobiology of Cerebellar Evolution and Development. Llinas, R. (ed.) Chicago: A.M.A. (1969) 493-514.
- 298 Walberg, F. The Trigemino-olivary projection in the cat as studied with retrograde transport of horseradish peroxidase. Exp. Brain Res. 45 (1982) 101-107.
- 299 Walberg, F., Kotchabhakdi, N., Hoddevik, G.H. The olivo-

- cerebellar projections to the flocculus and paraflocculus in the cat, compared to those in the rabbit. A study using horseradish peroxidase as a tracer. Brain Res. 161 (1979) 389-398.
- 300 Walberg, F., and Jansen, J. Cerebellar corticovestibular fibers in the cat. Exp. Neurol. 3 (1961) 32-52.
- 301 Walberg, F. Descending connections to the inferior olive. An experimental study in the cat. J. Comp. Neurol. 104 (1956) 77-174.
- 302 Watson, C.R.R., and Switzer, R.C., III. Trigeminal projections to cerebellar tactile areas in the rat - origin mainly from n. interpolaris and n. principalis. Neurosci. Lett. 10 (1978) 77-82.
- 303 Watson, P.J. Nonmotor functions of the cerebellum. Psychological Bulletin 85 (1978) 944-967.
- 304 Woody, CD., and Brozek, G. Changes in evoked responses from the facial nucleus of the cat with conditioning and extinction of an eye blink. J. Neurophysiol. 32 (1969) 717-726.
- 305 Woody, CD., and Engel, J., Jr. Changes in unit activity and thresholds to electrical microstimulation at coronal-pericruciate cortex of cat with classical conditioning of different facial movements. J. Neurophysiol. 35 (1972) 230-241.
- 306 Woolston, D.C, Kassel, J., and Gibson, J.M. Trigemino-cerebellar mossy fiber branching to granule cell layer patches in the rat cerebellum. Brain Res. 209 (1981) 255-269.
- 307 Yeo, CH., Hardiman, M.J., Glickstein, M., and Russell, I.S. Lesions of cerebellar nuclei abolish the classically conditioned nictitating membrane response. Soc. Neuroscience Abstr. 8 (1982) 22.
- 308 Yu. J., Tarnecki, R., Chambers, W.W., Liu, CN., Konorski, J. Mechanisms mediating ipsilateral limb hyperflexion after cerebellar paravermal cortical ablation or cooling. Exp. Neurology 38 (1973) 144-156.
- 309 Yu, J. The pathway mediating ipsilateral limb hyperflexion after cerebellar paravermal cortical ablation or cooling in cats. Exp. Neurology 36 (1972) 549-562.